

# HOME AUTOMATION AND COUNTERMEASURE SYSTEM USING ARDUINO AND LDR MODULE

G.N.S.R.B. Chaitanya<sup>1</sup>, Aishwarya Pasumarthy<sup>2</sup>, S. Kavya<sup>3</sup>, Dr. V.Jayaprakasan<sup>4</sup>, Dr .G .Prasad Acharya<sup>5</sup>

<sup>1,2,3</sup> B.TECH Scholars ,Dept. of Electronics and communication Engineering Hyderabad-501301, India

<sup>4,5</sup> Professor ,Dept. of Electronics and communication Engineering, SNIST, Hyderabad-501301, India

\*\*\*

**Abstract**—The improvement in technology and more tools being invented which are robust and capable of performing complex tasks gave an advantage to intruders to easily get into secured locations, access the physical data and steal the sensitive data outside the facility which is a great security threat to the organization and to the owners of the data there are many places where the intruder escaping successfully out of the facility with the data is more dangerous than him breaking into the facility. So in our project Intruder will be detected and also user will be intimated about the breach. Thefts and burglary attempt at banks and jewelry stores is a major issue as it may lead to a massive property loss and impose a threat to the economy. The existing intruder detection techniques used intimate the authorities and it is too late until they arrive. While there has been much research on sharing the breach data with the user, few researchers have taken inhibiting the intruder without escaping the facility into consideration which could be a great asset for the high security vaults containing valuable positions or classifieds such as museums bank lockers etc. The priceless artwork or the hard-earned money of people need to be securely stored and in any case of breach the data must be kept safe and cannot cross the perimeter of the facility but most of the existing researchers emphasize on using smartphone apps or GSM technology to intimate the user and if there is no signal at any time then the notification is delayed hence it would be too late before any action is taken. We are proposing to build a microcontroller- based device which can authenticate the user to enter a secured area and sense a potential breach using a laser tripwire system and intimate about the breach using a buzzer and activate a countermeasure system which can be deployed to not let the intruder escape until a correct password is entered and the authentication is done.

**Index Terms**—Arduino, laser tripwire, intruder, LDR Module, Countermeasure system

## I. INTRODUCTION

The advancement of technology and the development of more tools capable of performing complex tasks enabled intruders to easily gain access to secure locations, access physical data, and steal sensitive data outside the facility, posing a significant security risk to the organization and the data owners. There are many places where the intruder successfully escaping from the facility with the data is more dangerous than him breaking in.

There are many intrusion detection software's/devices present in the world which use different technologies to intimate the users about the presence of an intruder using both internet and/or GSM technologies, but there are few/no software's or devices which can inhibit the intruder from getting into the facility or not letting him escape out.

## II. LITERATURE REVIEW

While there has been much research on sharing the breach data with the user, few researchers have taken inhibiting the intruder without escaping the facility into consideration which could be a great asset for the high security vaults containing valuable positions or classifieds such as museums bank lockers etc. The priceless artwork or the hard-earned money of people need to be securely stored and in any case of breach the data must be kept safe and cannot cross the perimeter of the facility but most of the existing researchers emphasize on using smartphone apps or GSM technology to intimate the user and if there is no signal at any time then the notification is delayed hence it would be too late before any action is taken. Some of the existing technologies indicate the presence of an intruder by using ultrasonic sensor to sense the distance between the intruder and the door to light up LEDs of different colors this could be highly inefficient as there can be a false alarm and since the alerts is in the form of an LED these need to be constantly monitored and any human negligence can lead to mishaps. Other technologies include GSM communication short for global system for mobile communication to send an alert SMS to the user when an

intruder is detected. The intruder is detected using an IR or PIR sensor where PIR sensor detects the motion of any object within its range and an IR sensor which detects the presence of intruder using proximity between the object and the sensor. The end result of this technology is an alert message sent to the user. The user is the end person to take action against or in favor of the alert message. This method is dependent on the SMS message sent to the phone if the mobile network is down or the GSM module cannot transmit message due to network issues then the alert message may not be transmitted to the user and the user may not even know about the breach hence no action may be taken against the intruder. Most of the researchers have shown interest in using an application or web portal using Internet to intimate the user about the intruder and sometimes along with the picture or video clip of the intruder attached to the message. Studies have shown that most of the breaches happen in a planned and systematic way and take not more than 4 minutes to be executed that is from the time an intruder breaks in takes what he needs and leaves the perimeter the overall time is less than 4 minutes.

The microcontrollers have less processing speed compared to fully equipped computers hence image or video clip will take more time to be processed and to be uploaded to the web portal this time is dependent on the network speed and quality if it takes much time to upload to the web, the user will be most likely notified after the deed is done and considering the time for an average person to respond to an app notification the phone and network conditions at the user and this may be less effective and efficient. Why not just reject the intruder's request to open the door? This is answered by the last type of researches which are a combination of passwords, sensors, cameras and electronic locks which work in Sync. If sensor detects the person password prompts turned on if entered correct password then the door lock opens if not a picture is taken and sent to the user via a mobile app. This system can be easily flawed if the intruder breaks in using a window or any backdoor where this facility is not provided.

### III. METHODOLOGY

This project primarily deals with the inhibition of the intruder by not letting him out of the facility consequently securing the artifacts or important assets inside the premise. In this paper, the facility goes into a complete lockdown state achieved by iron cages across the potential breach points and supplying these cages with AC currents powerful enough to tase the intruder upon touching the barriers. This will be password protected and controlled

by the user, but the system will not wait for the user's consent to put the facility under lockdown instead this will be done automatically once the potential breach is detected. This will give an advantage than the existing technologies as we are not only intimating the user about the potential breach but also stopping the intruder from working his way out with the valuables.

This project also embeds the advantage of home automation equipped with an IR sensor to detect people inside a room to control the light brightness and a temperature and humidity sensor to monitor the temperature of the room and maintain it under the pre-set parameter by the user. This project detects the intruder using a laser tripwire system attached at all the potential breach points so that the facility is completely secured. The laser tripwire system activates once the user has entered the password and press the button indicating that he is leaving the facility, while entering if the button is pressed again a password prompt will appear if the password is entered correctly the tripwire system will go to power down mode and let the user enter the facility. There will be a maximum of 3 tries to get the password correct if the user fails 2 enter the correct password within 3 tries, he will be considered as an intruder and the lockdown mode will be initiated. This system will have a battery backup in a case where the intruder cuts the main power supply to the facility to disarm any intruder detection software's present.

So, this project works as a home automation system when not armed with intrusion detection command and turns itself into an intrusion inhibitor or lockdown initiator of the facility when armed with the correct command and password by the user.

#### A. TOOLS UTILISED

In this project, the primary components are Arduino UNO, a 4x3 keypad, an LCD display, a Stepper motor, and pair of LDR module and Laser diode. Hence this project is economical and simple compared to existing devices. This project can be applied in any of the facilities where the main concern is of data being taken out of the secure location. The components used in this project are: 1) LDR module. 2) Laser diode. 3) DC side shaft motor. 4) 4x4 keypad. 5) 16x2 LCD display. 6) Arduino mega Micro controller. V-A-V-F are the component description.

**B. COMPONENT DESCRIPTION**

*B.1 LDR Module*

The LDR module short for Light dependent Resistor module is a device which is capable of detecting the change in light intensity in an area/ room. An LDR module uses a photo-resistor to detect the change in light intensity using the concept that resistance is inversely proportional to the free electrons and the number of free electrons in matter is directly proportional to the intensity of light incident on the surface of the material.

*B.2 Laser Diode*

The laser diode is a photo emitting device which can be utilized to generate and emit laser photons using voltage. The laser diode has a p-n junction diode, which when current is passed through it can generate enough breaking voltage so that energy of the photons emitted at the junction can be in the range of visible spectrum. Unlike a normal Light Emitting Diode, in a laser diode the emissions are stimulated, they have high output power and the emissions are unidirectional.



Fig. 3.1. The LDR module used in the project.



Fig.3.2. Laser diode

*B.3 DC Side Shaft Motor*

The DC Side Shaft Motor is used for high torque applications. The side shaft motor used in this project is assigned to work at 12volts and has a rotation speed of 300rpm. This motor contains two bidirectional terminals, hence this

motor is capable of rotating in both clockwise and counter-clockwise directions. The gear arrangement of this motor is so arranged such that maximum torque is achieved, but due to this arrangement, the shaft is moved to the side, hence the name side shaft motor.

The micro-controller used here has a pin output voltage of 5v, this is insufficient to drive the motor which uses DC 12v volts to work, hence a L298N motor driver IC board is being used which can convert AC mains supply to DC 12v supply. the l298N driver works by taking pin input from the micro-controller which can be used to take an indication to turn on the motor and actually turning on the motor by using 12v supply.



Fig. 3.3. Side Shaft Motor.



Fig. 3.4. L298N motor driver.

*B.4 4 X 4 Keypad*

A keypad is a device used to give input to the micro-controller usually from 0-9, A-D and "hash". There are many keypad orientations viz. 4x1, 4x3, 4x4. The numbers in the orientation indicate 4 rows and 4 columns. The most common range of orientations are 4x3 and 4x4 Beneath each key, there is a unique membrane switch connected to the external pins via a conductive trace forming a 4x4 grid. The 4x4 keypad has 8 pins i.e., 4 for 4 rows and 4 for 4 columns.

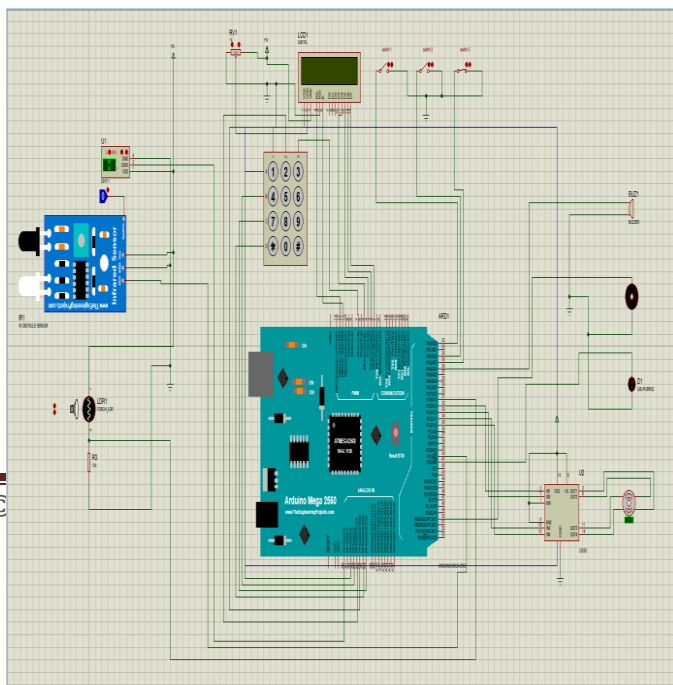

Fig. 4.2. Working Model-Circuit Diagram

There are 3 switches in this project. Switch one and switch two are placed inside the house to verify whether the user is going out or not. When switch one is pressed a prompt on the LCD display expressed is shown which asks the user to enter the password to perform any further actions. If the password entered is correct the control will display a message “going out?”, if not the action is ignored. If the user is going out, he needs to press switch to confirm the control that he is actually going out and that he wants to activate the security system. If switch two is pressed the control will wait for 30 seconds for the user to exit the facility after that the tripwires are activated. The 3 switches are so placed in the facility such that switch one and switch two are mounted inside the facility whereas switch three is mounted at the entrance.

When switch one is pressed and correct password is entered and switch two is pressed then the tripwire mechanism is activated when the user is back to the facility he needs to press switch three which is present outside the facility and a prompt will be displayed asking the user to enter password, if the correct password is entered the control will turn off the tripwire system assuming that the user has returned but if wrong password is entered the user will get 3 chances to enter the correct password, if he fails to enter correct password in all these 3 tries wrong then the control will assume that an intruder is trying to get into the facility and enter into lockdown mode, if the lockdown mode is to be disabled then switch three needs to be pressed again after some time and password needs to be entered if the correct password is entered the lockdown mode will be disabled and the changes will be reverted back.

While entering the password the 4 by 3 keypad is used and to indicate the end of the password \* is pressed. The password entered is then verified by the control with the preset password.



IV.I) Laser tripwire mechanism

When switch one is pressed and correct password is entered and simultaneously switch two is pressed then the laser tripwire mechanism is activated, that is the laser diode and the LDR module are activated.

The laser diode is an actuator which is used to incident laser light on any object it has 2 pins positive and negative the positive pin is connected to the digital pin of the and the negative pin is connected to the ground of the Arduino will stop.

The LDR module contains 3 pins VCC, ground, output. The VCC is connected to the 5 Volt pin of the Arduino whereas the ground is connected to the ground of the Arduino, the output pin is connected to the digital pin of Arduino.

The laser diode is so incident that it falls directly on the LDR module's photoresistor and hence when the laser light is incident the resistance is extremely low in the LDR module, but when any interruption in the incident light occurs then there is a spike in the resistance value indicating the laser line has been disturbed.

The fact that LDR module can detect change in incident lights and that when a laser is incident on the module the resistance is extremely low comes in favor to use this module and the laser diode as a pair for the tripwire mechanism.



When the tripwire is tripped the control assumes that an intruder is trying to enter the facility, and hence the control waits for a few seconds after that it initiates lockdown mode. In this case when the user enters the

Figure 5.1. O/P when switch 1 is pressed

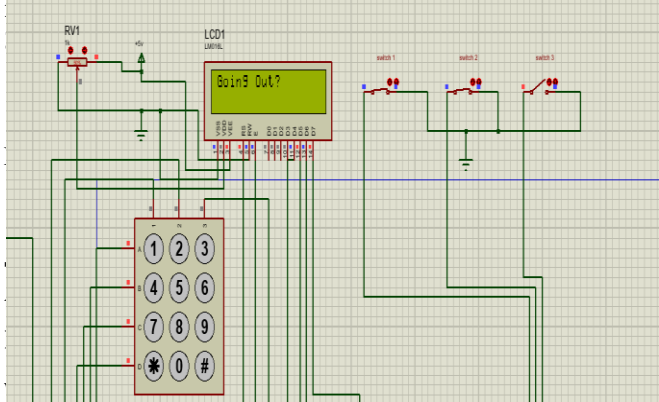

or when the password is entered wrong for 3 consecutive times the countermeasure system is activated.

This means that the stepper motor starts to run for a definite- steps for each entry point individually ultimately ceiling the facility shut.

The changes are reverted back that is the stepper motor is reversed when the correct password is entered after the lockdown has been initiated.

#### IV.RESULTS

When switch 1 is pressed, the control is displaying a welcome sign on the LCD display as intended. When correct password is entered the control is asking for confirmation if the user is going out or not.

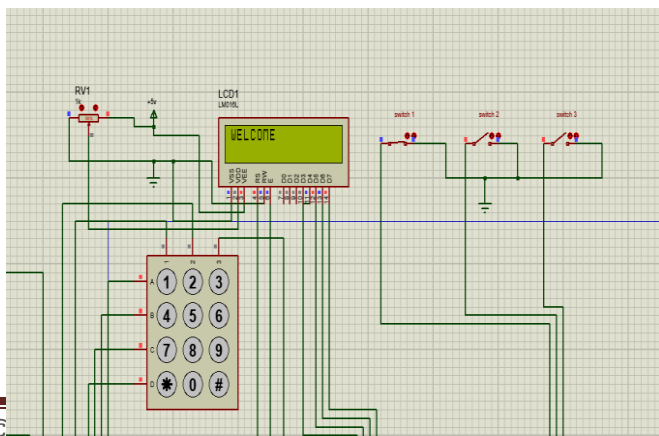

Figure 5.2 O/P when switch 1 is pressed and correct password is entered

If the user is intended to go out that is switch 2 is pressed, then a 30 seconds delay is given for the user to exit the premises the same is displayed on the LCD.

Figure 5.3. O/P when switch 2 is pressed

Figure 5.4. O/P when switch 3 is pressed

When switch 3 is pressed, the control displays a welcome sign on the screen and the password prompt is given.

If the password is entered correctly a welcome sign is displayed as shown in the figure above.

Figure 5.5. O/P when password entered is wrong

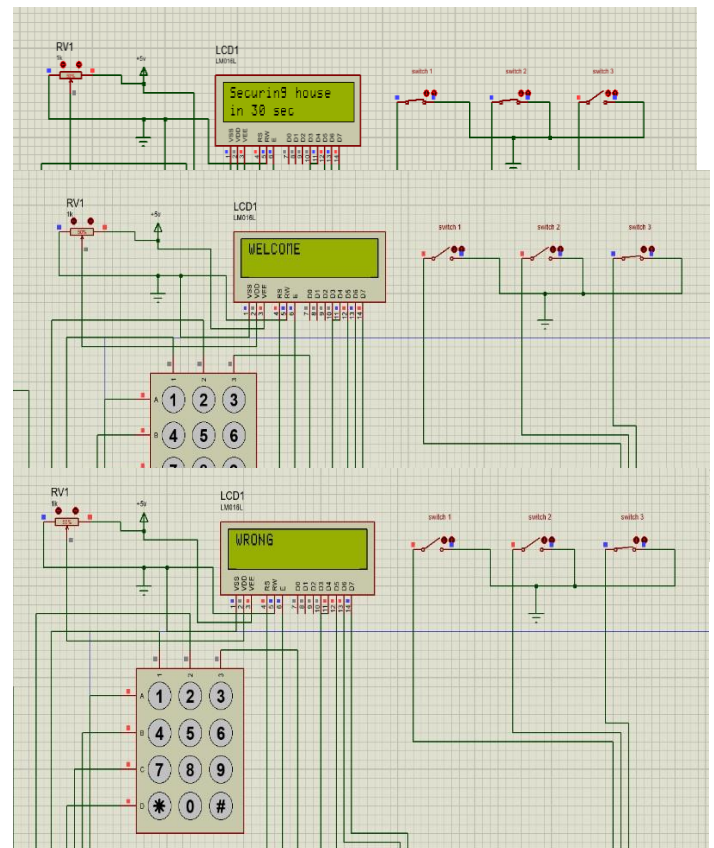



If the wrong password is entered a prompt displaying wrong password is shown on the LCD display, if the password entered is wrong for 3 consecutive times a prompt of unauthorized is being displayed.

Figure 5.8. Stepper motor response

In normal conditions the angle of the stepper motor is zero degrees but after lockdown initialization the angle increases to 315 degrees indicating that the potential breach points have been sealed.

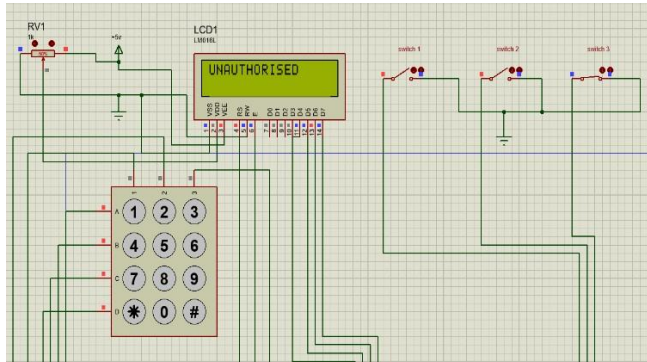

Figure 5.6. O/P when password entered is wrong for 3 consecutive times

A 30 seconds delay is given, a prompt displaying that securing house is given after that the stepper motor rotates indicating the lockdown initiation of the facility.

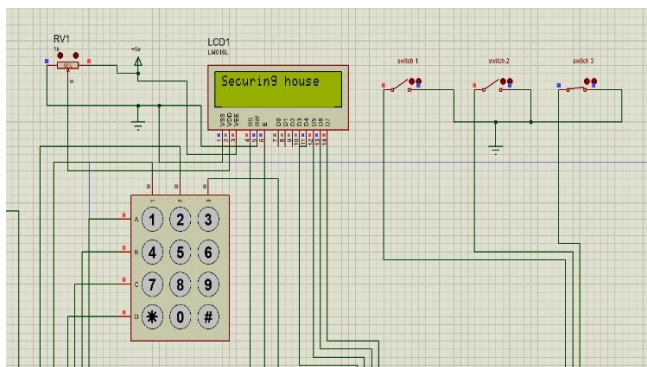
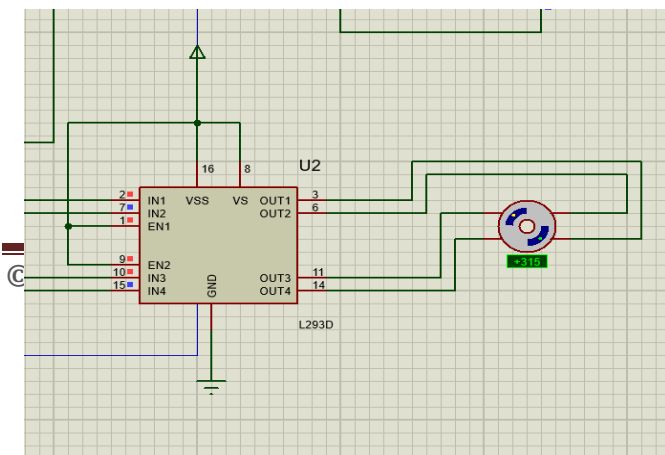

Figure 5.7. Device starting lockdown mode



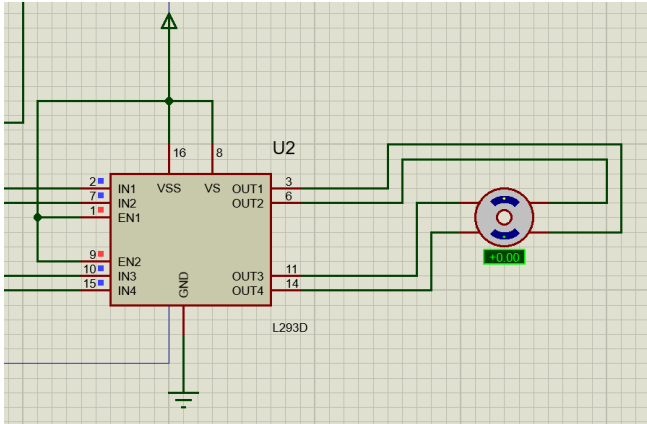

Figure 5.9. Initial stepper motor position

This concludes that the password-based security system is working fine.

When the switch 2 is activated that is when the user is going out the LDR module and laser diode are activated and since the laser diode is directly incident on the LDR module the input resistance is very low on the LDR module but when any change occurs in this path the resistance of the module increases indicating a low value to the microcontroller, the microcontroller is so program to take this change as an intrusion attempt and force the system to enter lockdown mode.

Figure 5.10. Response of device when tripwire is tripped

Figure 5.11. Response of stepper motor when tripwire is tripped

This indicates that the laser tripwire mechanism of the project is also working fine. The home automation features of the project are also verified and all are found to be working as expected.

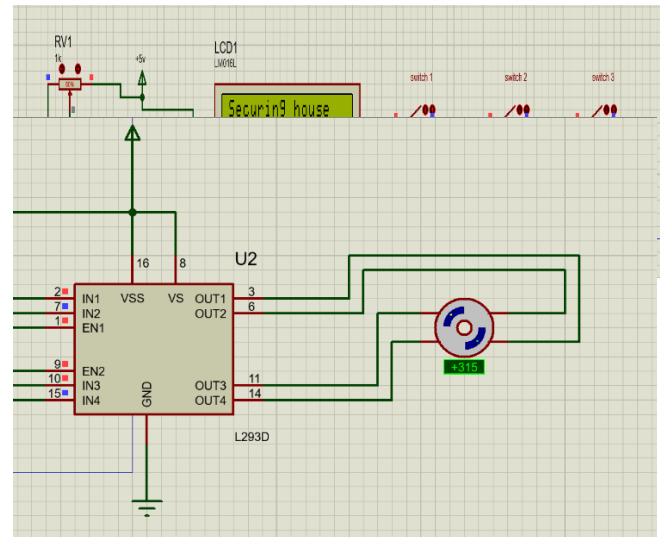

## V. CONCLUSION

Hence the intruder countermeasure system is successfully built using LDR module and stepper motors along with password protection. Unlike other researchers where the sole focus of the research was to intimate the user whenever an intrusion happens via SMS message or email or a mobile application where probably the picture of the intruder was taken and sent this project home automation and countermeasure system using LDR module and ordinance emphasizes the fact that not only intimating the user is necessary about the intrusion but also not letting the intruder escape out of the facility he's one of the primary concerns of a few areas this could be due to plethora of reasons but the existing solutions have not provided enough emphasis on this factor hence these are proven inefficient for these kind of facilities.

In the future all this mechanism can be integrated to a mobile app where the user can manually override the functions of the device and probably can alter the levels of security measures to be taken.

## VI. REFERENCES

[1] Lukman, Ajao & Olayemi Mikail, Olaniyi & Kolo, Jonathan & Adedokun, Emmanuel & Inalegwu, Ogbale & Sherif, Abolade. (2022). A Smart Door Security-Based Home Automation System: An Internet of Things. *Journal of Telecommunication*. 2. 1-9.

[2] J. Kumar, S. Kumar, A. Kumar and B. Behera, "Real-Time Monitoring Security System integrated with Raspberry Pi and e-mail communication link," 2019 9th International Conference on Cloud Computing, Data Science & Engineering (Confluence), 2019, pp. 79-84, doi: 10.1109/CONFLUENCE.2019.8776971.

[3] Oyekola, Peter & Oyewo, Taiwo & Oyekola, Abigail & Mohamed, Aezeden. (2019). Arduino Based Smart Home Security System. 8. 10.35940/ijitee.L3052.1081219.

[4] Nico Surantha, Wingky R. Wicaksono, Design of Smart Home Security System using Object Recognition and PIR Sensor, *Procedia Computer Science*, Volume 135,

2022, Pages 465-472, ISSN 1877-0509, <https://doi.org/10.1016/j.procs.2022.08.198>. (<https://www.sciencedirect.com/science/article/pii/S1877050918314881>)

[5] Mutinda, Mutava & Kamweru, Paul. (2020). Arduino Uno, Ultrasonic Sensor HC-SR04 Motion Detector with Display of Distance in the LCD. *International Journal of Engineering Research and* V9. 10.17577/IJERTV9IS050677.

[6] David, Nathan & Chima, Abafor & Aronu, Ugochukwu & Obinna, Edoga. (2015). Design of a Home Automation System Using Arduino. *International Journal of Scientific and Engineering Research*. 6.

[7] Upadhyay, Prashant and Yadav, Aniket and Thaker, Nehal and Makwana, Disha and Waingankar, Ninad, Theft Detection Using Data Science (May 7, 2021). *Proceedings of*

the 4th International Conference on Advances in Science & Technology (ICAST2021), Available at SSRN: <https://ssrn.com/abstract=3866857> or <http://dx.doi.org/10.2139/ssrn.3866857>

[8] M. N. Chowdhury, M. S. Nooman and S. Sarker, "Access Control of Door and Home Security by Raspberry Pi Through Internet," *Int. J. Sci. Eng. Res.*, vol. 4, pp. 550-558, 2013.

[9] Y. Zhao and Z. Ye, "A low-cost GSM/GPRS based wireless home security system," *IEEE Transactions on Consumer Electronics*, vol. 54, no. 2, pp. 567-572, 2008.

[10] IoT based Intruder Detection System Using GSM (April 8, 2020). Proceedings of the 3rd International Conference on Advances in Science Technology (ICAST) 2020, Iyer Saikumar and Gaonkar Pranjali and Wadekar Shweta and Kohmaria Nayan and Upadhyay Prashant.

[11] "Smart Home Automation Security: A Literature Review" *Smart Computing Review*, vol. 5, no. 4, August 2015, Arun Cyril Jose<sup>1</sup> and Reza Malekian<sup>2</sup>.

[12] Hack, Mobile Telecommunications Protocols for Data Networks, West Sussex, Hoboken: John Wiley & Sons, Ltd. (UK), 2003.

[13] Q. Hao, F. Hu and Y. Xiao, "Multiple human tracking and identification with wireless distributed pyroelectric sensor systems," *IEEE Systems Journal*, vol. 3(4), no. 428-439, 2009.

[14] Chitnis S, Deshpande N, Shaligram A. An investigative study for smart home security: Issues, challenges and countermeasures. *Wirel Sens Netw.* 2016;8(4):61.

[15] Sahoo KC, Pati UC. IoT based intrusion detection

system using PIR sensor. In: *Recent Trends in Electronics, Information & Communication Technology (RTEICT)*, 2017 2nd IEEE International Conference on. 2017. p. 1641-5.

[16] Tanwar S, Patel P, Patel K, Tyagi S, Kumar N, Obaidat MS. An advanced Internet of Thing based Security Alert System for Smart Home. In: *Computer, Information and Telecommunication Systems (CITS)*, 2017 International Conference on. 2017. p. 25-9