

Design and Analysis of Ignition based on RFID by Arduino Nano Compiler

Karibasavaraja D¹, Chirag², Deepak A³, Dhanush G M⁴, Praveen Kumar K⁵

¹Assistant Professor, Department of I&P Engineering, JSSTU, SJCE, Mysore

²Undergraduate, Department of I&P Engineering, JSSTU, SJCE, Mysore

³Undergraduate, Department of I&P Engineering, JSSTU, SJCE, Mysore

⁴Undergraduate, Department of I&P Engineering, JSSTU, SJCE, Mysore

⁵Undergraduatex, Department of I&P Engineering, JSSTU, SJCE, Mysore

ABSTRACT - The ultimate goal of this paper is incorporating of keyless security system for two-wheeler vehicle in order to have reliable, secured mechanism to safeguard two-wheeler vehicles from thieves. The other secondary objectives of this attempt are to develop keyless, user friendly, conventional locking system. As per our literature survey study, it's clearly indicating that now a days a lot of two wheelers vehicle has been stolen, average 10 to 15 vehicles per day have been stolen reported in Mysore district alone. Therefore, there is scope to develop the highly anti-theft security system to secure the best guarantee to protect the two-wheeler vehicle from different kinds of theft cases. In this paper, two-wheeler vehicles have been chosen, due to readily available with us. The methodology of this paper is the first stage will be the understanding the present unsafe locking mechanism. The second stage will be understanding complete keyless concepts and compatibility with existing product without changing major systems. By implementing this keyless highly secured system in two-wheeler vehicle it will protect the vehicles from thieves, gives 100% confident to user for safe guarding of their vehicles, easy handling, user friendly concept, saving natural resources by making of keys through this cost saving can be achieved. Easy handling and cost saving system. This system has many advantages over the present.

Key Words: Micro Controller, RFID Reader, Relay Drive, Regulated power source, Ignition system

1. INTRODUCTION

This paper is a fine combination of RFID technology and "Engine Ignition technology". It makes use of RFID reader to detect RFID tags. RFID reader uses various types of techniques like object detection and modulating and demodulating radio frequency.

In this paper we have used RFID technology. Main blocks of this paper are Microcontroller, RFID reader, Relay, LED and RPS. User has to place authorised RFID tag on the RFID reader. The main feature or specialty of RFID Tag is that it is unique. It gives this paper the high-level security than other security systems, such as Password based security

system. As RFID card are ergonomically designed in such a way that it can be carried in a wallet. Authorized RFID tag is read by a special type of sensor. RFID Reader can be interfaced with a microcontroller. Through software we can add activate new RFID tags and deactivate the existing user, also identify the user by selecting corresponding option through the software.

The main aim of this paper is to develop an authentication system on two-wheelers based on RFID that can be used to secure the two-wheeler from theft. In this paper we use a RFID reader to read once identity to turn on ignition system. For this, we use a microcontroller to enable the ignition system. If the matching between scanned data and the already existing data is correct, Ignition turns ON. This paper will utilize RFID reader as the input to acquire digital data and to ignite the engine.

2. Literature Survey (IGNITION BASED ON PASSWORD)

Many times, we hear the cases of bikes getting stolen from the parking area. Or sometimes we forgot to remove the keys from the bike by mistake. In these cases, it is really difficult to get the bike back. "Password based Lock for Bike security with ignition key" paper is designed to solve this purpose. The main concept behind this paper is a bike security system using a password entered through a keypad. This system turns on the Buzzer when the wrong password is entered 3 times.

Whenever user inserts key in ignition lock, LCD displays shows message as "Enter Password:". User has to enter password using Keypad provided with this electronics paper. If the entered password is correct then Relay and DC motor is turned on.

User can change this password anytime he/she wishes using a keypad. This changed password is stored in external EEPROM memory IC. Thus, bike security system paper can store the changed password even if there is power cut.

2.1 Description in detail:

Password lock for bike paper mainly consists

1. Microcontroller: This is the CPU of electronic lock for bike paper. Here microcontroller of 8051 family is used.

The various functions of microcontroller are

- I. Reading the digital input from Keypad
- II. Sending this data to LCD, so that the person operating this paper should read the password
- III. Sensing the password using keypad and to check whether it is a correct password or a wrong password and rotate the motor if the password entered is a correct password.

2. LCD: Here 16×2 alphanumeric Liquid Crystal Display (LCD) is used, which means it can display alphabets along with numbers on 2 lines each containing 16 characters.

3. Buzzer: Here buzzer is used to indicate the wrong password to open the ignition.

4. Keypad: User will enter the password using the keypad.

Various keys of keypad are as following,

- I. 0 to 9
- II. Enter.
- II. Escape.

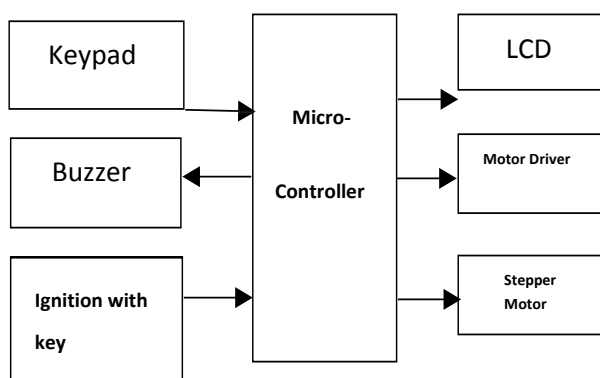
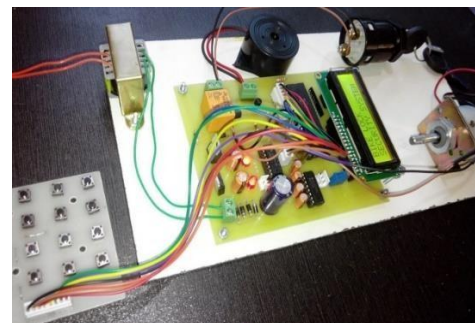
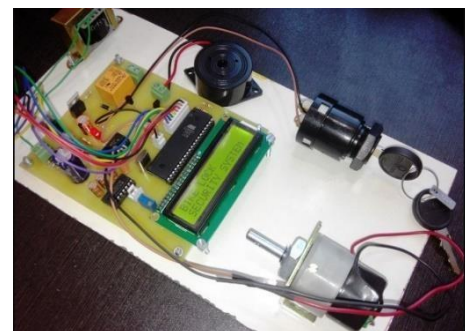

Fig: Block diagram of "Electronic lock for bike"

2.2 Pictures of "Electronic lock for bike:



2.3 Applications and Advantages:

- 1. Password based Lock for Bike security with ignition key paper can be used in various bikes.
- 2. The password detector paper can be used to automate the ignition locking process, so the user need not to carry the ignition lock keys along with them, they can just remember the password and use it later to open the ignition.

3. PRESENT WORK

From the block diagram with the help of RFID reader and the input is provided to the microcontroller and on the basis of the input received from the RFID reader, microcontroller drives the output devices i.e., ignition system of the bike and the LED. Scanning and checking of the RFID tag is done with the help of the RFID reader and on the basis of the output of the module microcontroller drive the ignition system of bike. Only authorized RFID tag is stored in the module. If match condition occur ignition system of the bike is turned on.

- Vehicle Battery Source: - The power is supplied to the Arduino through a micro-USB cable.
- RPS: - Used for constant voltage and regulation. The minimum input voltage is between 6.8V – 24V.
- Microcontroller: - It is used for serial communication and execution of the program.
- RFID Reader: - Used to gather information from RFID tag.
- Relay Drive: - Switching the Relay for Current Amplification.
- Relay: - Used for High voltage and Low voltage Isolation.
- LED: - LED is used, the red-light glows when the input is matched with the stored data and allows ignition to turn on.

- RFID Reader:** - Used to gather information from RFID tag.
- Relay Drive:** - Switching the Relay for Current Amplification.
- Relay:** - Used for High voltage and Low voltage Isolation.
- LED:** - LED is used, the red-light glows when the input is matched with the stored data and allows ignition to turn on.

3.2 TECHNICAL SPECIFICATION

Software Components

1. Programming language (Embedded-C).
2. Arduino nano Compiler.

Programming language (Embedded System)

An embedded system is an application that contains at least one programmable computer (typically in the form of a microcontroller, a microprocessor or digital signal processor chip) and which is used by individuals who are, in the main, unaware that the system is computer-based. This type of embedded system is all around us. Use of embedded processors in passenger cars, mobile phones, medical equipment, aerospace systems and defence systems are widespread, and even everyday domestic appliances such as dishwashers, televisions, washing machines and video recorders now include at least one such device.

Arduino Software

The Arduino programming language is a simplified version of C/C++. If you know C, programming the Arduino will be familiar. If you do not know C, no need to worry as only a few commands are needed to perform useful functions. An important feature of the Arduino is that you can create a control program on the host PC, download it to the Arduino and it will run automatically. Remove the USB cable connection to the PC, and the program will still run from the top each time you push the reset button. Remove the battery and put the Arduino board in a closet for six months. When you reconnect the battery, the last program you stored will run. This means that you connect the board to the host PC to develop and debug your program, but once that is done, you no longer need the PC to run the program.

Hardware Components

1. Regulated Power Supply
2. Relay
3. Relay Drive
4. RFID reader
5. Arduino
6. LED

3.1 METHODOLOGY

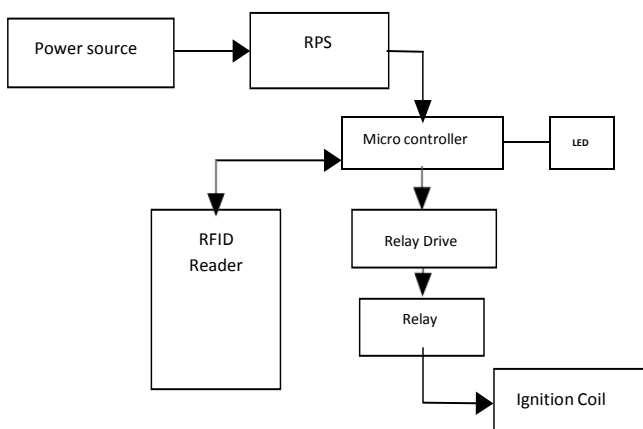

Fig: Block diagram prototype

From the block diagram with the help of RFID reader and the input is provided to the microcontroller and on the basis of the input received from the RFID reader, microcontroller drives the output devices i.e., ignition system of the bike and the LED. Scanning and checking of the RFID tag is done with the help of the RFID reader and on the basis of the output of the module microcontroller drive the ignition system of bike. Only authorized RFID tag is stored in the module. If match condition occur ignition system of the bike is turned on.

Vehicle Battery Source:- The power is supplied to the Arduino through a micro USB cable.

RPS: - Used for constant voltage and regulation. The minimum input voltage is between 6.8V – 24V.

Microcontroller: - It is used for serial communication and execution of the program.

1. Regulated Power Supply

A Regulated Power Supply is an embedded circuit; it converts unregulated AC into constant DC.

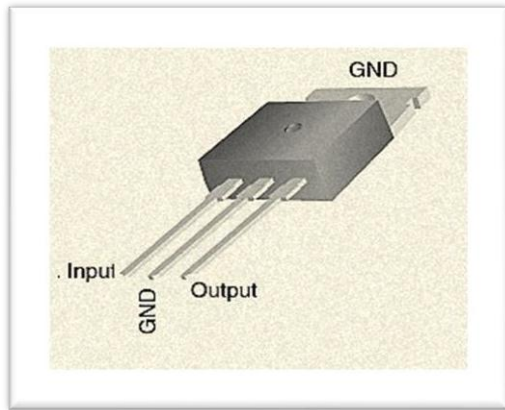

Fig: RPS

With the help of a rectifier, it converts AC Supply into DC. Its function is to supply a stable voltage (or less often current), to a circuit or a device that must be operated within certain power supply limits. The output from the regulated power supply may be alternating or unidirectional, but is nearly always DC. The type of stabilization used may be restricted to ensuring that the output remains within certain limits under various load conditions, or it may also include compensation for variations in its own supply source. The latter is much more common today.

2. Relay

A Relay is an electrically operated switch. Current flowing through the coil of the relay creates a magnetic field which attracts a lever and changes the switch contacts.



Fig: Relay

The coil current can be on or off, so relays have two switch positions and they are double throw (changeover) switches. Relays allow one circuit to switch a second circuit

which can be completely separate from the first. For example, a low voltage battery circuit can use a relay to switch a 230V AC mains circuit. There is no electrical connection inside the relay between the two circuits; the link is magnetic and mechanical. The coil of a relay passes a relatively large current, typically 30mA for a 12V relay, but it can be as much as 100mA for relays designed to operate from lower voltages. Most ICs (chips) cannot provide this current and a transistor is usually used to amplify the small IC current to the larger value required for the relay coil. The maximum output current for the popular 555 timer IC is 200mA so these devices can supply relay coils directly without amplification.

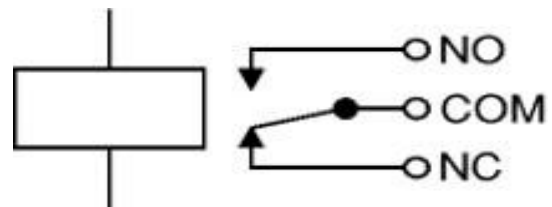

The relay's switch connections are usually labelled COM, NC and NO: COM = Common, always connect to this; it is the moving part of the switch. NC = Normally Closed, COM is connected to this when the relay coil is off. NO = Normally Open, COM is connected to this when the relay coil is on.

3. Relay Drive

6. LED

Relay driver circuit, is a circuit which can drive, or operate, a relay so that it can function appropriately in a circuit. The driven relay can then operate as a switch in the circuit which can open or close, according to the needs of the circuit and its operation.



Fig: Relay Drive

4. RFID



Fig: RFID reader and tag

Radio-frequency identification (RFID) uses electromagnetic fields to automatically identify and track tags attached to objects. An RFID system consists of a tiny radio transponder, a radio receiver and transmitter. When triggered by an electromagnetic interrogation pulse from a nearby RFID reader device, the tag transmits digital data, usually an identifying inventory number, back to the reader. This number can be used to track inventory goods. Passive tags are powered by energy from the RFID reader's interrogating radio waves. Active tags are powered by a battery and thus can be read at a greater range from the RFID reader, up to hundreds of meters.

Unlike a barcode, the tag does not need to be within the line of sight of the reader, so it may be embedded in the tracked object. RFID is one method of automatic identification and data capture (AIDC).

5. Arduino

The Arduino microcontroller is an easy to use yet powerful single board computer that has gained considerable traction in the hobby and professional market. The Arduino is open-source, which means hardware is reasonably priced and development software is free.

This is what Arduino Board looks like.



Fig: Arduino

The Arduino board features an Atmel ATmega328 microcontroller operating at 5 V with 2 Kb of RAM, 32 K of flash memory for storing programs and 1 Kb of EEPROM for storing parameters. The clock speed is 16 MHz, which translates to about executing about 300,000 lines of C source code per second. The board has 14 digital I/O pins and 6 analog input pins. There is a USB connector for talking to the host computer and a DC power jack for connecting an external 6-20 V power source, for example a 9 V battery, when running a program while not connected to the host computer. Headers are provided for interfacing to the I/O pins using 22 g solid wire or header connectors.

6. LED

A Light-emitting diode (LED) is a two-lead semi conductor light source.



Fig: LED

The switching ON of the device is indicated when LED (Red) glows.

Needs for Working System

Connect your Arduino to the computer with the USB cable. You do not need the battery for now. The green PWR LED will light. If there was already a program burned into the Arduino, it will run. Start the Arduino development environment. In Arduino-speak, programs are called “sketches”, but here we will just call them programs.

In the editing window that comes up, enter the following program, paying attention to where semi-colons appear at the end of command lines.

```
void setup()
{
  Serial.begin(9600);
  Serial.println("Hello World");
}
void loop()
{}
```

Click the Upload button or Ctrl-U to compile the program and load on the Arduino board. Click the Serial Monitor button. If all has gone well, the monitor window will show your message and look something like this.

Click the Upload button or Ctrl-U to compile the program and load on the Arduino board. Click the Serial Monitor button. If all has gone well, the monitor window will show your message and look something like this.

Push the Arduino reset button a few times and see what happens.

If there is a syntax error in the program caused by a mistake in typing, an error message will appear in the bottom of the program window. Generally, staring at the error will reveal the problem.

If you continue to have problems, try these ideas Run the Arduino program again

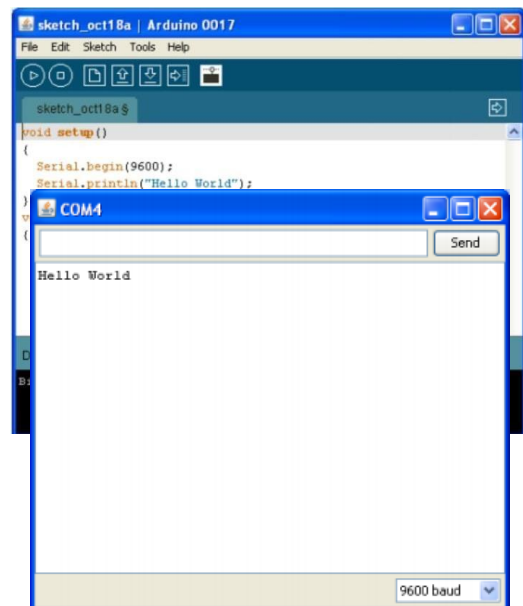

- Check that the USB cable is secure at both ends.
- Reboot your PC because sometimes the serial port can lock up
- If a “Serial port...already in use” error appears when uploading
- Spacing to be done, in required part of the vehicle.
- Corrosion of the RFID reader due to weather conditions.
- RFID tags can be stolen.

4. RESULTS AND DISCUSSIONS

- RFID technology automates data collection and vastly reduces human effort and error.
- There is no need to remember the password or any Pin number.
- One of the main advantages is that this system remembers the stored data, even if the power supply is turned off.
- It is a compact circuit which makes it very easy to install in the two-wheeler.
- It can be used in moped as well as in gear bikes.
- User friendly.
- Spacing to be done, in required part of the vehicle.
- Corrosion of the RFID reader due to weather conditions.
- RFID tags can be stolen.
- RFID technology gains time more than other security system such as password and key.

Sample paragraph Define abbreviations and acronyms the first time they are used in the text, even after they have been defined in the abstract. Abbreviations such as IEEE, SI, MKS, CGS, sc, dc, and rms do not have to be defined. Do not use abbreviations in the title or heads unless they are unavoidable.

In future this paper can be expanding further with fingerprint recognition also. In this paper we can add GPS to trace the vehicle's exact location. Data can be sent to a remote location using mobile or internet.

- Other related modules like fire sensor, GSM modem can be implemented.
- It can be permanently installed next to the handle bar in the two-wheeler, with an environment friendly body design.
- In the future, smartphone can be interfaced by using Bluetooth or Wi-Fi connectivity.
- This can be further implemented in four-wheelers as well.

Limitations

- RFID technology gains time more than other security system such as password and key.

The Prototype of the model is as shown below

Fig: Prototype of the model

Working Prototype of the model

- Step 1: - RFID tag is placed on the RFID reader.
- Step 2: - If Input is matched, red light glows and ignition starts.
- Step 3: - If the input is not matched, when step 1 is carried out. The LED will not glow, which indicates using unauthorized RFID tag.

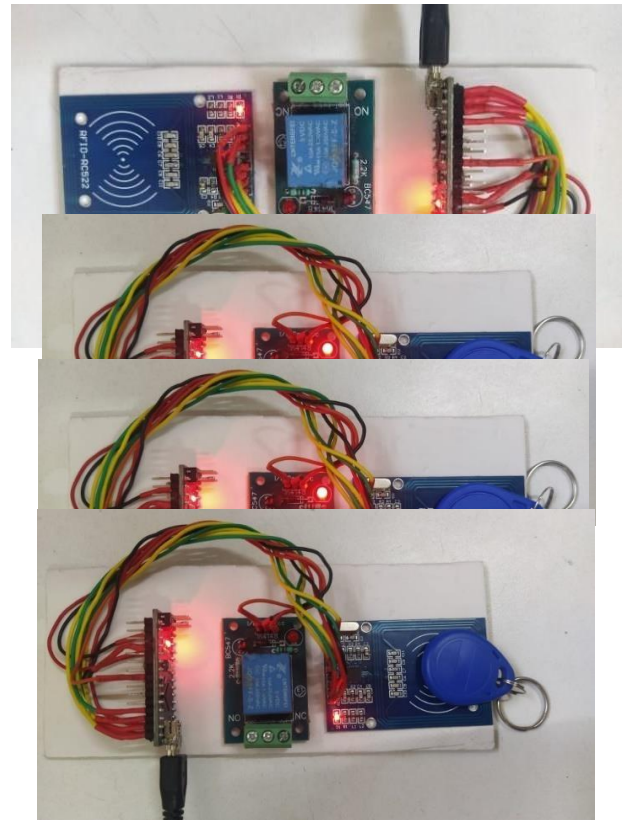

The result is that the bike will be ignited only when the authorized RFID is scanned on the RFID reader. The digital data of the authorized tags is stored in the RFID reader. When any person places authorized tag on the RFID reader, then the data of the placed tag is matched with the stored data in the module. If the RFID data is found in the module, then match condition occurs and the microcontroller ignites the bike otherwise bike will not start.

5. CONCLUSIONS

The prototype of a RFID-based ignition system developed has a specific sequence that must be followed before it can be used to ignite a vehicle. Basically, the RFID recognition software must be first initialized before frequency data can be loaded from a file of sample frequency. The last acquired RFID is then analyzed and its minutiae identified, extracted and stored as a template. The next step involves either enrolling the template or matching the template with other templates. The enrolment process button saves the last extracted template into the database. The identity number of the enrolled template is displayed in the log window. The identification process compares the query template against reference templates in a database. For verification, the identity number of the reference template to be matched with the query template must be supplied. In the results, it can be deduced that the use of RFID security systems offers a much better and fool proof means of restricting the ignition of vehicles by unauthorized users. Furthermore, it can be logically derived from the findings of this research work that RFID signal can be used for motor vehicle ignition system control. Parallel port control codes used with RFID analysis codes can provide capabilities for allowing only authorized users, authenticated through their RFID tags to ignite a vehicle.

Now-a-days thefts and accidents are increasing. To prevent from these problems this paper is implemented. The theft is controlled by the RFID matching process.

REFERENCES

- [1] "Radio frequency identification"
<https://www.fda.gov/radiation-emitting-products/electromagnetic-compatibility-emc/radio-frequency-identification-rfid>
- [2] <https://www.techopedia.com/definition/26992/radio-frequency-identification-reader-rfid-reader>
- [3] <https://www.atlasrfidstore.com/rfid-beginners-guide/>
- [4] Visa M. Ibrahim "Microcontroller Based Anti-theft Security System Using GSM Networks with Text Message as Feedback" Published in International Journal of Engineering Research and Development e-ISSN: 2278-067X, p-ISSN: 2278-800X, www.ijerd.com Volume 2, Issue 10 (August 2012), PP. 18-22
- [5] Lin Hong. "Automatic Personal Identification Using Fingerprints", Ph.D. Thesis, 1998.

[6] Yang S. and Verbauwhede I. (2003) "A Secure RFID Matching Technique",
<http://www.emsec.ee.ucla.edu/pdf/2003acm.pdf>

[7] <http://auto.howstuffworks.com/ignitionsystem.htm>,
"How Automobile Ignition Systems Work "

[8]

- <http://www.RFIDinfo.org/.htm>, "RFID Information Resource" [9]
- <http://www.crimtrac.gov.au/RFIDanalysis.htm>, "RFID Analysis - The Basics" [10] R. K. Singh, "Crime in India 2011 - Statistics", for National Crime Records Bureau 2011 [11]
- <http://www.gogle/Ebedtronics>.
- [9] AlphaSigmaura Team (2005) "Computer Interfacing and control", Paper presented at the workshop on Computer Interfacing and Control, LadokeAkintola University of Technology, Ogbomoso, Nigeria.
- [10] Anton S. (2002) "Sorting it out: Machine learning and fingerprints", Paper presented at the seminar on Telematik fingerprint, Siemens Corporate Technology, Munich, Germany.
- [11] Engdahl T. (2005) "Parallel port interfacing made easy", <http://www.epanorama.net>
- [12] Graevenitz G.A. (2003) "Introduction to RFID technology", A&S International, Vol. 53, pp. 84 - 86.
- [13] <http://auto.howstuffworks.com/ignitionsystem.htm>, "How Automobile Ignition Systems Work "
- [14] <http://www.biometricinfo.org/fingerprintrecognition.htm>, "RFID Inforce"

BIOGRAPHIES



Karibasavaraja D, Assistant Professor, Department of I&P Engineering, JSSTU, SJCE, Mysore



Chirag , Undergraduate , Department of I&P Engineering, JSSTU, SJCE, Mysore



Deepak A, Undergraduate , Department of I&P Engineering, JSSTU, SJCE, Mysore



Dhanush G M, Undergraduate , Department of I&P Engineering, JSSTU, SJCE, Mysore



Praveen Kumar K, Undergraduate , Department of I&P Engineering, JSSTU, SJCE, Mysore