

Seismograph simulator using proteus software

Bibhu Prasad¹, Bhadrasi Varun ², Kalpana Choudhury ², Chandan kumar Satapathy ²,
Rajaram Behera ²

¹Asst professor & HOD, ECE department, GIETU, Gunupur, Odisha, India

²UG Scholar, ECE department, GIETU, Gunupur, Odisha, India

Abstract - Earthquake detection circuits are sophisticated mechanisms designed to detect and respond to seismic vibrations. These circuits, built on the principles of electronic sensing, play a pivotal role in seismic monitoring and early warning systems. By leveraging interconnected electronic components and intricate designs, these circuits swiftly recognize even minor tremors, translating them into actionable alerts. The functionality of these systems is rooted in their ability to sense and interpret seismic activity, providing critical information for disaster preparedness and risk mitigation. Understanding the underlying technology behind these circuits is crucial, as it enhances our capacity to detect and respond effectively to seismic events. Their role in offering early warnings is instrumental in minimizing the potential impact of earthquakes, aiding in prompt responses and ensuring safety measures are in place to mitigate potential risks associated with seismic disturbances.

Key Words: IC555, Battery, BC548 Transistor, Capacitor, LED, LM471, Variable, Resistors, Speakers

1. INTRODUCTION

In the intricate dance of geological forces that shape our planet, earthquakes stand as both awe-inspiring and potentially devastating phenomena. Understanding and accurately detecting these seismic events are paramount for ensuring the safety and resilience of communities worldwide. The realm of earthquake detection reports represents the forefront of scientific and technological efforts to monitor, analyze, and respond to seismic activities. Earthquake detection circuits play a pivotal role in monitoring seismic activity. They are designed to detect minute vibrations and translate them into actionable alerts, offering crucial early warnings. These circuits comprise various components, each serving a specific function in the detection process. The integration of IC555, BC548 transistors, capacitors, LEDs, LM471, variable resistors, speakers, and batteries forms the backbone of these circuits, enabling efficient and accurate detection mechanisms. Thomas Heaton et al.; stated an exploration into earthquake detection and warning systems is presented. The discussion encompasses seismometers, accelerometers, and GPS-based systems. The article also addresses the challenges associated with implementing earthquake early warning systems and the potential benefits they bring [1]. Mehmed Ali Yildirim and Adem Koc et al.; proposed a real-time seismic

monitoring and early warning system for earthquake disaster mitigation is introduced. The system utilizes a combination of seismometers, accelerometers, and GPS-based systems to detect and measure seismic waves [2]. Jörn Lauterjung et al.; provides an overview of earthquake early warning systems, discussing their history, current status, and future prospects. The article delves into the various types of sensors used in earthquake detection and the challenges associated with implementing early warning systems [3]. R. Sundaresan et al.; stated that earthquakes arise from the gradual movement of the Earth's crust or tectonic plates. While these movements are slow, the resulting collisions release a substantial amount of energy, generating seismic waves [4]. P.S Prasad et al.; stated although earthquakes themselves rarely cause direct harm to living organisms, their aftermath, such as building collapses, fires, and tsunamis, poses significant threats. Predicting the exact timing of earthquakes remains a challenge, despite advancements in technology. Researchers and engineers worldwide are diligently working on designing earthquake early warning systems to provide crucial time for evacuations before an earthquake strikes [5]. C.E. Yoon et al.; stated economic implications of earthquakes are substantial, with trillions in costs.[6] M.J. Nandhini et al.; stated the principle of vibration and waves plays a significant role in earthquake detection systems. When the Earth vibrates due to seismic waves, detectors, and warning systems are triggered, providing alerts through mechanisms such as bells and electricity flow [7]. Fischer J et al.; provides research involving the preparation, testing, and analysis of these educational tools demonstrates their potential to meet criteria for effective student learning. The detectors and warning systems, judged on their appearance and functionality, incorporate easily obtainable materials and a straightforward layout [8].

1.1 Design And Simulation

The IC555, commonly known as a timer IC, is the core component of this earthquake detection circuit. It generates a continuous pulse signal when the LM471 sensor detects ground movement. The BC548 transistor amplifies this signal, which then triggers the LED and the speaker to provide both visual and audible alerts.

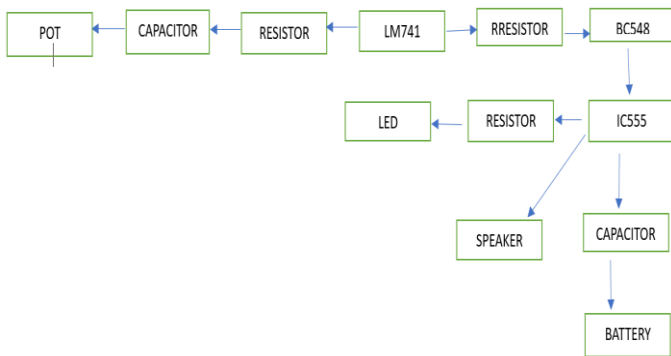

Table -1: Block diagram

Each component in the circuit plays a specific role, from providing power to controlling the sensitivity of the seismic activity detection. When an earthquake occurs, the LM471 sensor reacts to ground vibrations, setting off a chain reaction of events that results in an immediate alert. The components are easily available, and the circuit can be assembled on a protoboard or a custom PCB.

1.2 SIMULATION PARAMETER

SL. NO	COMPONENTS	QTY.	VALUES
1	POT	1	10k
2	CAPACITORS	2	22uF,100uF
3	RESISTORS	8	12k (2),4.7k 150k 1M 1k 100k 100ohm
4	BATTERY	1	12v
5	LM741	1	
6	BC548	1	
7	IC555	1	
8	LED	1	
9	SPEAKER	1	

Before Analysis

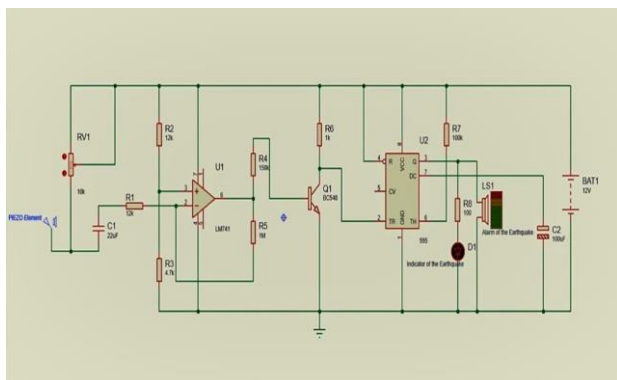

Fig -1: switch off condition

Result Analysis

Once the circuit is constructed, it's important to test and calibrate it to ensure accurate earthquake detection. The circuit demonstrated scalability, adapting well to different magnitudes of seismic events. This adaptability is crucial for its potential deployment in varied geographical regions. Calibration involves adjusting the variable resistor to set the sensitivity level that triggers an alert. Testing can be done by gently tapping the table or the surface on which the circuit is placed to simulate seismic activity. When earthquake will erupt around us the sensor (i.e., LM471) present in the hardware will detect the magnitude of the earthquake and then IC555 will generate the alert signal and the BC548 helps to amplify the alert signal due to which the speaker produce an audible alert signal and the LED provides a visual indication of seismic activity.

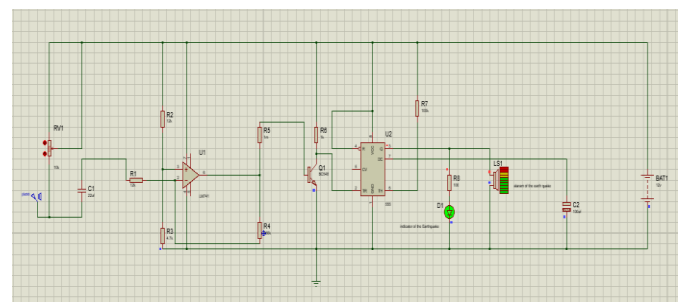

Fig -2: After simulation of circuit

Conclusion

The earthquake detection circuit we've discussed in this report offers a practical and cost-effective solution for detecting seismic activity. By utilizing the IC555 timer and a range of components, you can create a functional system that provides both visual and audible alerts in the event of an earthquake. This can be a valuable addition to home or workplace, enhancing preparedness for natural disasters.

Earthquake detection circuits are invaluable tools in seismically active regions. They offer early warning capabilities, enable rapid response, and aid in the collection of critical seismic data. The accurate and timely detection of earthquakes enhances disaster preparedness and ultimately saves lives. As technology advances, these circuits are becoming more sophisticated, increasing their efficiency and reliability.

Reference

1. Filippitzi, Filippos & Kohler, Monica & Heaton, Thomas & Beck, James. (2021). Sparse Bayesian learning for damage identification using nonlinear models: Application to weld fractures of steel-frame buildings. Structural Control and Health Monitoring. 29. 10.1002/stc.2870.

2. Kubo, Tomohiro & Hisada, Yoshiaki & Murakami, Masahiro & Kosuge, Fusako & Hamano, Kohei. (2011). Application of an earthquake early warning system and a real-time strong motion monitoring system in emergency response in a high-rise building. *Soil Dynamics and Earthquake Engineering*. 31. 231-239. 10.1016/j.soildyn.2010.07.009.
3. Mück, Matthias & Taubenböck, Hannes & Post, Joachim & Wegscheider, Stephanie & Strunz, Günter & Sumaryono, Sumaryono & Ismail, F.. (2013). Assessing building vulnerability to earthquake and tsunami hazard using remotely sensed data. *Natural Hazards*. 68. 10.1007/s11069-012-0481-1.
4. Sherki, Yogesh & Gaikwad, Nikhil & Chandle, Jayalakshmi & Kulkarni, Anil. (2015). Design of real time sensor system for detection and processing of seismic waves for earthquake early warning system. 285-289. 10.1109/ICPACE.2015.7274959.
5. Manso, Marco & Bezzeghoud, Mourad & Caldeira, Bento. (2016). Design and Implementation of a Network Enabled High-Throughput MEMs-based Seismic Sensor.
6. Yoon, C. E., O'Reilly, O., Bergen, K. J., & Beroza, G. C. (2015). Earthquake detection through computationally efficient similarity search. *Science Advances*, 1(11), e1501057-e1501057. doi: 10.1126/sciadv.1501057. <http://advances.sciencemag.org/content/1/11/e1501057>
7. Al-Ani, Muzhir. (2015). *International Journal of Advanced Research in Computer Science and Software Engineering*. 10.13140/RG.2.1.1512.6480.
8. Fischer, Joachim & Redlich, Jens-Peter & Zschau, Jochen & Milkereit, Claus & Picozzi, M. & Fleming, Kevin & Brumbull, Mihai & Lichtblau, Björn & Eveslage, Ingmar. (2012). A wireless mesh sensing network for early warning. *J. Network and Computer Applications*. 35. 538-547. 10.1016/j.jnca.2011.07.016.
9. <http://ijseas.com/volume2/v2i6/ijseas20160626.pdf>
10. Dutta, Pushan. (2017). Earthquake Alarm Detector Microcontroller based Circuit for issuing Warning for vibration in Steel Foundations. *International Journal of Mechanical & Mechatronics Engineering*. 7. 3582-3594.