

EXPLORING THE POTENTIAL OF PORTABLE SOLAR PANEL SYSTEMS USING STEPPER MOTOR

Mr. Bhatt Parth Ashishkumar¹, Mr. Dhavde Yash Devendrabhai²

^{1,2} Department of ICE

L.D. College of engineering Ahmedabad 380015

Abstract - This research paper presents the design and implementation of a portable solar panel system tailored to meet the growing demand for remote power generation in an era of escalating interest in renewable energy sources. With a focus on sustainability and accessibility, portable solar panels emerge as a promising solution to address the energy needs of remote areas. The project entails meticulous selection of efficient solar panels and the development of a compact, user-friendly design to facilitate seamless transportation and setup. The resultant system exhibits robust power generation capabilities, rendering it suitable for diverse applications such as outdoor events and off-grid living scenarios. By bridging the gap between renewable energy technologies and practical deployment, this project contributes significantly to the advancement of clean energy solutions across various contexts

Key Words: Nema17 stepper motor, TB6600 stepper motor driver, 8051 microcontroller board, Arduino UNO, Relay module, Linear Electric Actuator and SMPS.

1. INTRODUCTION

The increasing global demand for clean and sustainable energy sources has led to growing interest in portable solar panels as a promising solution for addressing energy needs in remote and off-grid locations. Portable solar panels are compact, lightweight devices equipped with solar cells that convert sunlight into electricity. The adoption of portable solar panels is driven by several factors, including advancements in solar technology, declining costs of solar components, and increasing awareness of environmental sustainability. With improvements in efficiency and durability, modern portable solar panels have become more reliable and affordable, making them accessible to a wider range of users. The versatility of portable solar panels makes them suitable for various applications across different sectors. In outdoor recreational activities, such as camping, and hiking. Portable solar panels provide a convenient and eco-friendly way to recharge electronic devices, power lighting systems, and run small appliances. In this research paper, we aim to provide a comprehensive analysis of portable solar panels, exploring their design principles, technological advancements, applications, and future prospects.

1.1 Objectives

1. Evaluate the efficiency of portable solar panels in various environmental conditions.
2. Analyze the effectiveness of different portable solar panel designs and technologies in terms of power generation, portability, and ease of use.
3. Explore innovative methods to enhance the efficiency and energy output of portable solar panels through technological advancements.
4. Examine the compatibility of portable solar panels with various devices and equipment, including electronic equipment.
5. Investigate user perceptions and preferences such as ease of setup, maintenance requirements, and overall satisfaction.

1.2 Literature Review

Stepper Motor Technology used in Portable Solar Panel: A stepper motor is a type of motor that moves in discrete steps, rather than continuously rotating like a traditional motor. It works by using electromagnetic coils to attract and repel permanent magnets on a rotor, causing it to move in precise increments. Stepper motors are controlled by sending a sequence of pulses to their coils, which determine the direction and number of steps the motor takes.

Applications of Portable Solar Panel:

Portable solar panels are utilized for camping, emergency preparedness, off-grid living, military operations, disaster relief, remote worksites, education, agriculture, outdoor events, and humanitarian aid, providing renewable energy for charging devices and powering equipment in remote or inaccessible areas.

Integration with IoT and Cloud Computing:

Recent advancements in Internet of Things (IoT) and cloud computing technologies have significantly enhanced the capabilities of stepper motor monitoring systems in portable solar panel. Integration with IoT enables real-time data transmission, remote monitoring, and data analytics. Cloud-based platforms facilitate data storage, accessibility, and collaboration, allowing stakeholders to make informed decisions based on historical and real-time stepper motor position data.

Energy-Efficient Designs and Power Management:

Developing energy-efficient design and effective power management systems for portable solar panels maximize energy harvest from the sun, prolongs battery life, and enhances overall system reliability, making portable solar panels ideal for capture, storage, and utilization, optimizing performance in varying conditions while enhancing sustainability for off-grid applications in remote or resource-constrained environments.

Challenges and Future Directions:

Challenges for portable solar panels include enhancing efficiency, durability, and affordability while addressing intermittency issues. Future directions involve integrating advanced materials and technologies to improve energy capture, storage, and portability. Innovations in flexible and lightweight designs, coupled with smart power management systems, will enable wider adoption in off-grid scenarios, disaster relief efforts, and sustainable development initiatives.

Conclusion:

In conclusion, the literature review highlights the growing importance of portable solar panels in addressing energy needs for remote and mobile applications. Advancements in photovoltaic technology have significantly improved efficiency and affordability, making these panels a viable solution for sustainable energy. Studies show their effectiveness in diverse settings, from outdoor activities to emergency power supply. Despite challenges such as weather dependency and storage limitations, ongoing innovations promise enhanced performance and user adaptability. Overall portable solar panels represent a crucial step towards achieving energy independence and environmental conservation.

2. DESIGN AND IMPLEMENTATION OF PROPOSED SYSTEM:

1) 8051 MICROCONTROLLER BOARD

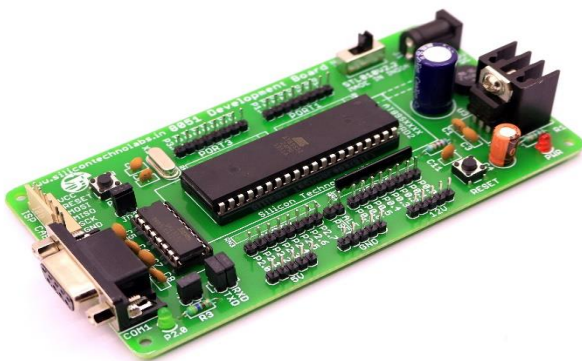

Fig: 8051 Microcontroller Board

The 8051 microcontroller, developed by Intel in 1980, is an 8-bit microcontroller widely used in embedded systems. It features an 8-bit CPU, 128 bytes of RAM, 4KB of ROM, 32 I/O pins, two 16-bit timers/counters, a five-vector two-level interrupt architecture, a full-duplex serial port, and on-chip oscillator and clock circuitry. The 8051 microcontroller board typically includes additional components like a crystal oscillator for clock generation, reset circuitry, voltage regulators, and sometimes an interface for external memory expansion. It supports various interfacing options for peripherals such as LCDs, keyboards, ADCs, and sensors, making it ideal for learning and development purposes in microcontroller programming and embedded systems projects. The board can be programmed using assembly language or C, with numerous development tools and resources available. Its robustness, simplicity, and wide acceptance make it a popular choice for educational and prototyping applications.

2) ARDUINO UNO BOARD



Fig: Arduino UNO

The Arduino Uno lies the Atmega328P microcontroller, which provides processing power and I/O capabilities for controlling electronic components. The Uno board features a set of digital input/output (I/O) pins (14 in total), which can be configured as either inputs or outputs, allowing it to interface with various digital sensors, LEDs, motors, and other peripherals. Additionally, it includes six analog input pins, enabling the reading of analog sensors. The Uno can be easily connected to a computer via USB, allowing for programming and communication with the board. Arduino provides a user-friendly IDE that simplifies the process of writing, compiling, and uploading code to the Uno board. Arduino Uno is compatible with a wide range of expansion boards called "shields," which add additional functionalities such as wireless communication (Wi-Fi, Bluetooth) and many more.

3) RELAY MODULE

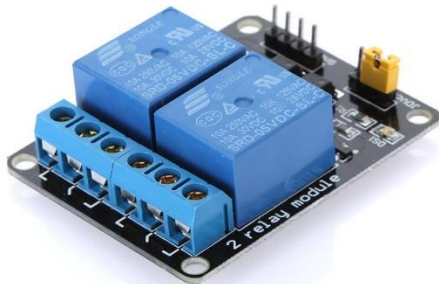

Fig: Relay Module

Relays are electromechanical switches that open or close circuits based on the application of a control signal. They consist of an electromagnetic coil that, when energized, generates a magnetic field, causing movable contacts to change position. These contacts physically connect or disconnect the circuit. In this instance, we controlled a 240V pump using a Two-channel 5V relay board. Maximum current for the relay is 10A at 250 volts AC or 10A at 30 volts DC, This board has three high-power, connections: Common (COM), Normally Open (NO), and Normally Closed (NC) with 5V VCC, GND, and control pins.

4) TB6600 STEPPER MOTOR DRIVER



Fig: Stepper Motor Driver

The TB6600 stepper motor driver is a high-performance microstepping driver compatible with NEMA 17, 23, and 34 stepper motors. It operates within a voltage range of 9V to 42V and provides a maximum current output of 4.5A. The driver supports multiple micro-stepping resolutions,

including full step, half step, 1/8, 1/16, and 1/32 steps, allowing for precise motor control. It features built-in protection mechanisms such as thermal shutdown, overcurrent protection, and short-circuit protection, enhancing its reliability. The TB6600 is equipped with a robust heatsink for effective heat dissipation. Commonly used in CNC machines, 3D printers, robotics, and other automation projects, the TB6600 is easy to interface with popular microcontrollers like Arduino and Raspberry Pi. It offers adjustable current settings through DIP switches, enabling customization based on the motor's requirements. Its versatility and reliability make the TB6600 a popular choice for both hobbyists and professionals seeking precise and efficient stepper motor control.

5) NEMA17 STEPPER MOTOR

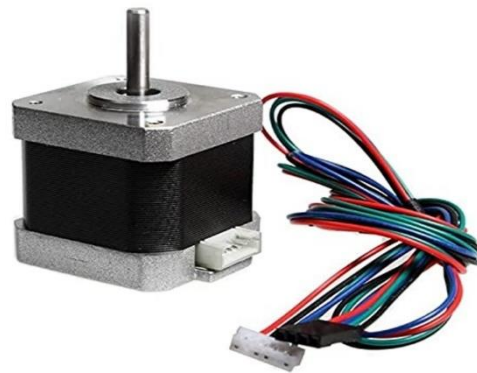

Fig: Stepper Motor

The 4.4 kg NEMA17 stepper motor is a compact yet powerful motor With a holding torque of 4.4 kg-cm (or approximately 0.43 Nm), it provides sufficient torque for precise and reliable motion control. This motor operates with a step angle of 1.8 degrees per step, resulting in smooth and accurate movement. It typically has a standard NEMA17 frame size, making it easy to integrate into existing designs and compatible with a wide range of mounting brackets and couplings. The NEMA 17 stepper motor is a popular type of stepper motor characterized by its 1.7 x 1.7-inch (43.2 x 43.2 mm) faceplate, commonly used in 3D printers, CNC machines, and robotics. It typically offers a step angle of 1.8 degrees, meaning 200 steps per revolution, which provides precise control over motion. The motor usually operates at a voltage range of 2.8V to 12V, with a current rating of around 1.2A to 2.5A per phase, depending on the specific model. It delivers holding torque in the range of 3.5 kg-cm to 5.5 kg-cm, suitable for applications requiring accurate positioning and repeatability. The NEMA 17 can be easily controlled using various stepper motor drivers like the TB6600. It is known

for its reliability, ease of use, and adaptability in a wide range of motion control applications.

6) LINEAR ELECTRIC ACTUATOR



Fig: Linear Electric Actuator

A linear electric actuator is a device that converts electrical energy into linear motion. It consists of a motor, a lead screw or belt mechanism, and a housing. The motor generates rotational motion, which is then converted into linear motion by the lead screw or belt mechanism. Linear electric actuators come in various sizes and load capacities to suit different applications, ranging from small-scale automation tasks to heavy-duty industrial machinery. These actuators offer precise control over linear movement, with options for speed and position adjustment. They are commonly used in applications such as industrial automation, automotive systems, medical equipment, and home automation. Linear electric actuators provide advantages such as high efficiency, low maintenance requirements, and quiet operation compared to hydraulic or pneumatic alternatives. Overall, linear electric actuators offer reliable and efficient solutions for linear motion control in a wide range of industries.

7) WORKING OF THE CIRCUIT DIAGRAM

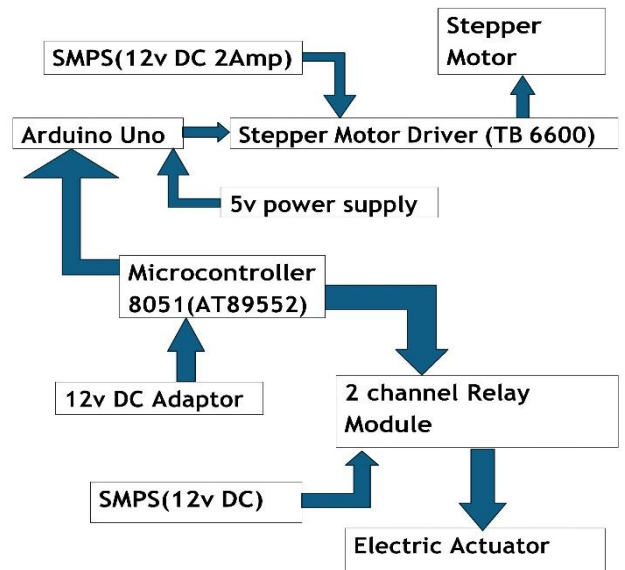

➤ Construction

Here the entire frame is made by square pipe of Iron. The size of the main Iron frame is 46×30 Inch. The solar panel Iron frame size is 28×22 inch. We have done silver color on this Iron frame. We used 50 watt solar panel in the portable solar panel robot so we made the size of the solar panel frame according to the size of the 50 watt solar panel. A 50-watt solar panel weight is around 4 to 5 kg and 540 mm x 670 mm x 30 mm small-sized photovoltaic module that can convert sunlight into electrical energy. It typically consists of 36 to 72 solar cells that are interconnected to produce a DC voltage output of around 12 to 24 volts and might have three amps (Isc) and 2.78 amps (Imp).

❖ The Actuator is controlled by 8051 microcontroller board and relay module.

Here the AT89S52 IC used in the 8051 microcontroller board. There are 4 port available in the microcontroller board so we are using port 0 for interfacing with relay module. The pin P0.0 and P0.1 of the port 0 is connected with the IN1 and IN2 pin of the relay module to send pulse signal from the microcontroller also 5v and GRN pin of the relay is connected to the microcontroller board for power up the relay module.

Here 2 relay used to expand and contract the actuator. Relay 1 and 2 each has 3 pin (NO, GRD and NC) so both NO pin is connected with each other, , Both NC pin in connected with each other,

the SMPS supply provide to the GRD pin of the relay. The actuator Positive + wire is connected with the NC pin and negative - wire is connected with the NO pin. The SMPS connected to the relay because the actuator run on the 12v 2A supply.

❖ **Stepper is controlled by 8051 microcontroller board, Arduino UNO and TB6600 Stepper Motor Driver.**

Here the 8051 microcontroller is connected with arduino UNO for the rotating the stepper motor. The P1.0 pin of the port 1 is connected to the Digital pin 3 of the arduino UNO. When the P1.0 is activate then signal 1 is send to the arduino pin 3 that time the arduino send signal to the stepper motor driver to rotate the stepper motor.

The Arduino UNO, a popular microcontroller board, can be effectively integrated with the TB6600 stepper motor driver to control stepper motors. Arduino UNO communicates with TB6600 via digital pins, sending step and direction signals to drive the motor accurately. This combination enables precise motion control in various applications such as CNC machines, 3D printers, and robotic systems. The digital pin 2 and 5 is connected to the Direction pin and Pulse pin of the stepper motor driver.

The 12v 2A power supply connected to the VCC and GND pin of the driver. Here we are using 4 step stepper motor so according to the 4 wire of the stepper motor is connected with the A+, A-, B+, B- pin of the driver. After that set the switch of the driver according to the current rating and micro stepping of the stepper motor. Finally write the program in the arduino to rotate the stepper according to the requirement of the position after that digital pin 2 and 5 send signal to pulse pin and direction pin of the driver to reach desired stepper motor position.

❖ **SMPS and DC adaptor provide power supply in the entire circuit.**

Here the SMPS is connected with the relay module and Stepper motor driver and DC adaptor connected to the 8051 microcontroller board & Arduino board.

➤ **Working**

Here the stepper motor connected with the solar panel frame using Metal rod and Gear mechanism so according to the rotation of stepper motor upon particular degree of angle the frame also rotate with the stepper motor to generate maximum energy from the sun. We have done program in a circuit to rotate stepper

motor with a direction of the sun. In this portable solar panel circuit diagram we are using the components such as 12v DC SMPS, 8051 microcontroller board, arduino UNO, 2 channel relay module, TB6600 stepper motor driver, NEMA 17 stepper motor and Linear electric actuator. The rotating of stepper motor at precise degree of angle by using AT89S52 IC and Arduino UNO. We explain step by step working of the portable solar panel robot.

Before ON the power supply check all wiring properly in the entire circuit. After power on the entire circuit, first the actuator start to expand. here the actuator stroke is 100mm long and actuator expand & contract 7mm/second. The 8051 microcontroller send signal to IN1 pin of the 1st relay. When IN1 activate the actuator start to expand. The delay of expand the actuator is given below,

Delay for expand the actuator,

$$D=S*T,$$

Here we find time T so,

$$T= D\%S$$

$$T= 100\text{mm} \% 7\text{mm}/\text{sec} = 14.285 \text{ second},$$

Here we are using 15 second time delay to expand & contract the actuator.

Between this 15 second actuator lift up the solar panel frame. After 15 second the 8051 microcontroller board P1.0 pin will give signal to the digital pin 3 of the arduino for rotate the stepper motor. After that arduino communicate with the stepper motor driver to rotate the stepper motor according to the position requirement. The constant 12v 2A power supply provide by SMPS to power up the driver. The arduino pin 2 (Pulse signal) and 5 (Direction signal) send signal to the driver. According to these two signal stepper motor start to rotating. According to do this our aim is the solar panel frame rotate total 180 degree of angle according to the sun position to generate maximum energy from the sun so we have used 3 time period, according these we have done program in the arduino. So basically sun rising at 6 am and falling at 6 pm so we divided this 12 hr. time into 3 time period. First is 6 am to 10 am, second is 10 am to 2 pm and third is 2 pm to 6 pm.

Stepper motor rotation angle is,

$$180 \text{ degree} \% 3 \text{ time period} = 60 \text{ degree/ time period.}$$

The stepper motor rotates 60 degree according to given pulse signal by arduino. Let's calculate pulse signal for 60 degree angle, Stepper motor has 200 step at 360 degree of angle so,

$$360 \text{ degree} \% 200 \text{ step} = 1.8 \text{ degree of angle}$$

If you will give 1 pulse signal then stepper motor rotate 1.8 degree of angle. Here we want to rotate 60 degree angle so let's calculate,

1.8 % 60 = 33 pulse signal.

In these 3 time frame stepper motor takes 33 pulse signal for each 60 degree of rotation. After each rotation of 60 degree angle we kept 5 second delay so after complete these 3 time frame stepper motor done 180 degree of angle. The position of each 60 degree of the solar panel will generate maximum energy from the sun.

At 6 pm stepper motor will come at initial position at 0 degree of angle and after 10 second the microcontroller send signal to the IN2 pin of the 2nd relay. After that actuator start to contract for 15 second. This process will continuously working at daily 6am to 6pm.



Fig: Proposed System

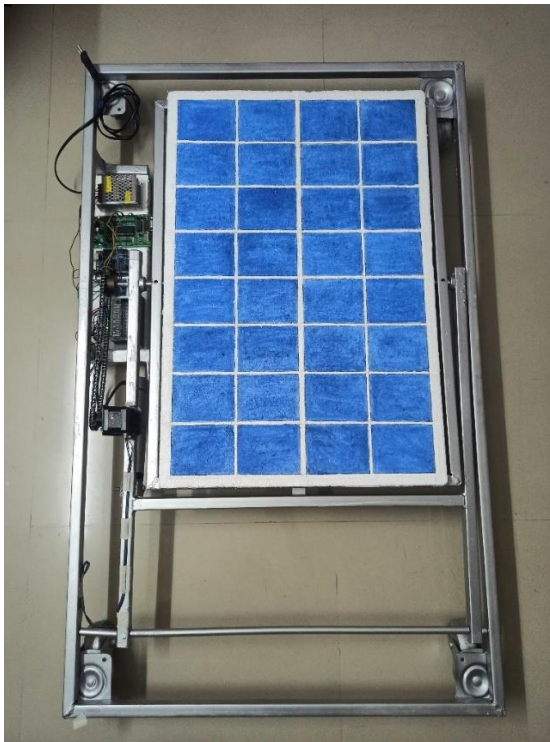

Fig: Proposed System



Fig: Proposed System

3. CONCLUSION

In conclusion portable solar panel systems offer a versatile and sustainable solution for remote power generation. Their ability to harness renewable energy sources enhances accessibility and resilience in various settings, from outdoor adventures to emergency situations and off-grid living. With continued advancements in technology and design, portable solar panels play a vital role in promoting energy independence and environmental stewardship.

REFRECES

1. Ali O M Maka, Jamal M Alabid, "Solar energy technology and its roles in sustainable Clean Energy", Volume 6, Issue 3, June 2022
2. "All You Need to Know About Portable Solar Panels", September 21, 2022
3. Galib hashmi, Md. Shamim hasan, Md. Mazedul Haque Efat & Md. Habibur - "Portable solar panel efficiency measurement system", Published: 10 December 2019 Volume 2, article number 56, (2020)
4. Binyamin jasim, Pooya taheri - "An Origami-Based Portable Solar Panel System " 2018 IEEE 9th Annual Information Technology, Electronics and Mobile Communication Conference (IEMCON)