

VEHICLE LOCATION TRACKING SYSTEM USING GSM, GPS AND GEOFENCING TECHNIQUES

Suhas R¹, Prajwal S², Vimallesh J³, Kiran K N⁴, Sarala T⁵

¹ Suhas R: Student, Dept. of ECE, BNM Institute of Technology, Karnataka, India

² Prajwal S: Student, Dept. of ECE, BNM Institute of Technology, Karnataka, India

³ Vimallesh J: Student, Dept. of ECE, BNM Institute of Technology, Karnataka, India

⁴ Mr. Kiran K.N: Assistant Professor, Dept. of ECE, BNM Institute of Technology, Karnataka, India

⁵ Sarala T, Assistant Professor, Dept. of ECE, BNM Institute of Technology, Karnataka, India.

Abstract – The tracking of vehicles is a very important aspect in many areas of traffic management. The GSM modem acts as the interface of the control room and is used to receive messages from the user. The received message is transmitted to the microcontroller and is also displayed on the electronic card equipped with the microcontroller. The Global Positioning System (GPS) is one among the satellites orbiting the earth. It sends back to earth details of their location in space. GPS has many uses as in the military field, weather conditions monitoring, vehicle positioning, agriculture, surveillance, and many other areas. Geofencing is a location-based service that allows marketers to send messages to smartphone users who fall within a predefined geographic area. In geofencing, a combination of technologies, including GPS, area-providing satellite navigation system, is made use to create a virtual boundary around a business location. In this work carried out we aim to provide for Vehicle Location Tracking system using GSM along with, GPS and Geofencing techniques.

1. INTRODUCTION

A novel system for vehicle location is proposed that using a aggregation of GPS, GSM and geofencing technology. This promises to revolutionize real-time tracking and monitoring at any location. The GPS module serves as a basis and ensures the correctness of obtaining the correct location. To achieve this, the GSM module provides connectivity at any location by simply connecting the data source to a central server. Integrating these components is a microcontroller that acts as a workstation, controlling data flow and performing complex geofencing algorithms. A comprehensive system is designed that includes the GPS along with the GSM modules, followed by central server for the purpose of data storage and using an intelligent geofencing algorithm. This makes it robust and able to meet the requirements of modern monitoring applications. The site tracking site promises to be efficient and secure, improving fleet performance with real-time vehicle tracking, protecting valuable assets and ensuring the well-being of people in remote or dangerous areas. This location tracking system incorporates advanced technology for providing a powerful, scalable, and efficient system for instant tracking

and monitoring. By leveraging the power of GPS, GSM and geofencing, the system unlocks the opportunity for efficient, secure, and situational awareness for a wide range of applications in a connected world.

The objective for developing location tracking using GSM together with GPS and Geofencing techniques is to allow for fast tracking in transportation and logistics that allows shipments to be monitored, optimized and delivery times faster. Integration of geofencing adds an additional layer of functionality that enables automatic response when a device enters or leaves a defined virtual area. This feature is crucial in parental control applications, fleet management together with security procedures and provides instant alerts of deviations from the plan. The proposed work aims to develop algorithms and methods that will ensure an increase the correctness of location information received from GPS together with GSM signals, especially in difficult situations. This work also aims to effectively leverage real-time data processing technologies to minimize delays in receiving, processing, and transmitting data sources.

2. LITERATURE SURVEY

In the “Intelligent monitoring of wireless environment through collection of time and analytics, by Satoko Itayaa, Fumiko Ohoria, Toru Osugaa, Takeshi Matsumuraa”, the authours have proposed and developed an environment monitoring system for real-time collection and analysis of wireless signals to monitor complex indoor wireless environments. The system uses commercial hardware and open-source software platforms suitable for continuous collaboration and open collaboration.

The research related to the applications of GPS-based wireless communication system in highway and slide Ziwen Xiong Xiong J. The research indicates that the wireless communication network GPS multi-system antenna tracking is very beneficial in terms of response time. Based on the work executed, the authors are of the opinion that the wireless communication network GPS multi-antenna tracking system is more accurate and has only small errors. [1]

Although the reliability of the application example has been verified, the test case scenarios are not good enough to demonstrate the system’s applicability in difficult areas. More testing and development are needed in the future. This paper also developed a time series model to estimate and verify the reliability of the model through experiments. The evidence of the examples in the Limitations of location tracking in transmission article and considering the legitimacy and costs of land security monitoring, the article has published a GPS multi-antenna monitor review based on wireless communication [2]

As per “The Frontiers of Space Travel” by Jay Stanley and Jennifer Stisa Granick. Global Positioning System. When phones turn on satellite detection, they can detect their location with an accuracy of 1 meter at best, but generally at depths of 5 to 20 meters outdoors. GPS radio signals are weak; The equipment is not used indoors and does not work satisfactorily near large buildings, in large cities, and during storms, typhoons and other severe weather conditions.

As soon as the GPS receiver is initially turned on or taken outside, it may take a few seconds to identify its location. Additionally, cell phones receive transmissions from GPS satellites but do not automatically calculate, store, or transmit GPS location information. April 8, 2020[3]. The Research on the application of GPS-based wireless communication system in highway landslides is done [4]. The Global Positioning System Wide Area Augmentation System (WAAS) Performance Standard is proposed[5]. The working of GPS is analyzed in detail [6]. The release of GPS to public from military is provided[7]. The advanced GPS control is presented [8]. The accuracy of GPS to 1 foot is discussed [9]. The GAM and its long-range capability are discussed in [10,11]

3. METHODOLOGY

This is a flowchart of a program that determines whether point is inside a polygon.

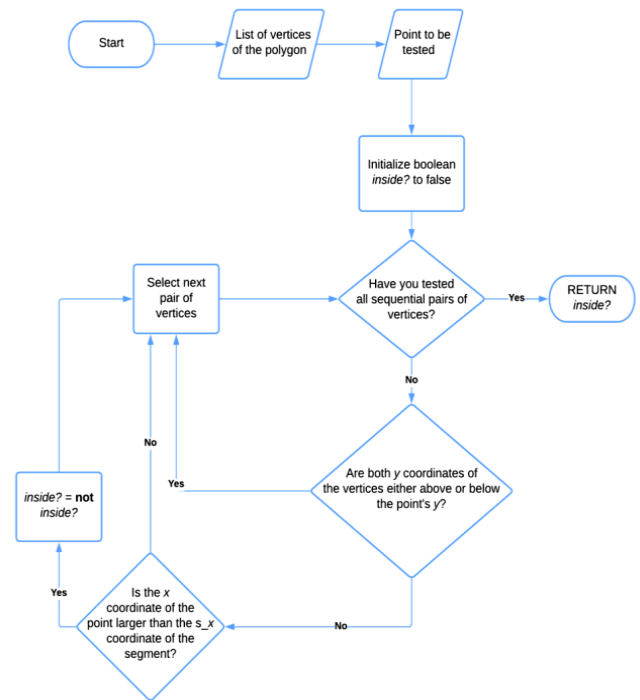

Fig -1: Geofencing Flowchart

The program first lists all the vertices of the polygon and the points we want to test. It then initializes the Boolean variable called ? wrong. The program then selects the next pair of vertices in the polygon. It then checks whether we have tried all pairs in a row. If so, the program returns the value of internal ? If we have not tried all vertices in a row, the program checks whether the y coordinate of present vertex pair is higher or lower compared to the y coordinate of the vertex pair we tried. If so, what about the program installed in it? Negation of the inside?

The program then checks whether the x coordinate of the point we are testing is greater than the x coordinate of the starting vertex of the current segment. If so, what about the program setting? In a negative way? When the program tests all connected vertical lines in the polygon, it returns the value of interior? Is it inside? If true, the point is inside the polygon. Is it inside? If false, the point is outside the polygon.

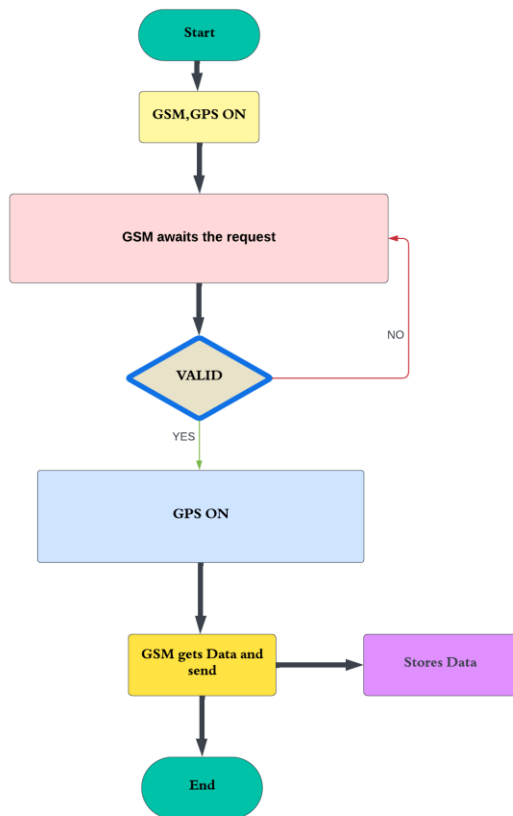

Fig -2: GSM, GPS Flowchart

This guide first checks if GSM along with GPS are enabled. In this case, the system waits for the user's request. The request could be for car parts, locking the engine, adjusting the speed or changing the number. If the request is valid, the system turns on the GPS. It further sends the request to the specific vehicle. The vehicle then moves, stops, or accelerates. GSM then retrieves the required data from the vehicle proceeding to save the data on a SD card. The end user can access the data on the SD card. Below is a more detailed description of each step in the flowchart:

1. GSM, GPS enabled

The system first checks whether GSM and GPS are enabled. Otherwise, the system cannot track the vehicle.

2. GSM Standby Request

GSM Standby request from users. The request could be for car parts, locking the engine, adjusting the speed or changing the number.

3. (Location/Engine Stop/Speed Limit/Number Change)

This is the request sent by the user to GSM. The request could be for car parts, locking the engine, adjusting the speed or changing the number.

4. No

If the request is invalid, the system proceeds to step 1.

5. Yes

If the request is valid, the system proceeds to step 6.

6. GPS ON (Send Request)

The system turns on the GPS and sends a request to the vehicle. The vehicle then moves, stops or accelerates.

7. GSM receives and sends data

GSM receives data from the vehicle and forwards the data to the SD card.

8. Store on SD Card

GSM stores the data on the vehicle in the SD card.

9. End User

The end user can access the data on the SD card.

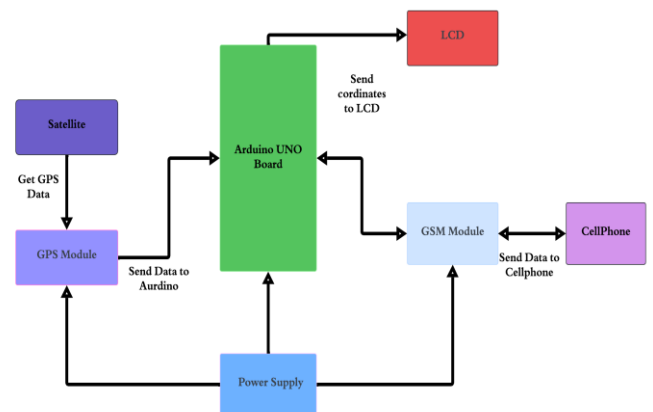

Fig -3: Block Diagram of Tracking System

Cell phones work primarily by receiving the signal from the cell phone. The signal is then decoded by the Arduino UNO board. The Arduino UNO board will send the output signal to the appropriate device such as LCD, GPS module or GSM module. Mobile phones can also send signals to mobile phones. For example, when a user calls, the phone sends a signal to the mobile phone to initiate the call. The block diagram shows how the different components of the phone work to make calls. Cell phones may also be used to send and receive text messages. Sending and receiving a text message is like making a phone call.

The block diagram also shows that a mobile phone may be used to track a user's location. The GPS module is used to track the user's location. The GPS module sends the user's location coordinates to the Arduino UNO board. The Arduino

UNO board will further send the user interface to the GSM module. The GSM module then sends the user's location check to the mobile phone. Cell phone cameras can track the user's location. A mobile phone is a complex device, but a block diagram shows how the different parts of a mobile phone work together to make it work.

4. IMPLEMENTATION

The implementation outlines a generic approach to creating a location tracking system using GPS, GSM, and geofencing technologies, with the Arduino UNO serving as the central control unit. The system is comprised of three main components: the GPS module, the GSM module, and the microcontroller (Arduino UNO). The GPS module continuously retrieves the device's current latitude and longitude coordinates. These coordinates are further processed by the Arduino UNO, which can trigger actions based on predefined conditions, such as entering or exiting a geofenced area.

The GSM module enables communication with remote devices or servers. In this implementation, it is utilized to send SMS alerts when the device enters or exits the predefined geofenced area as shown in Fig 4

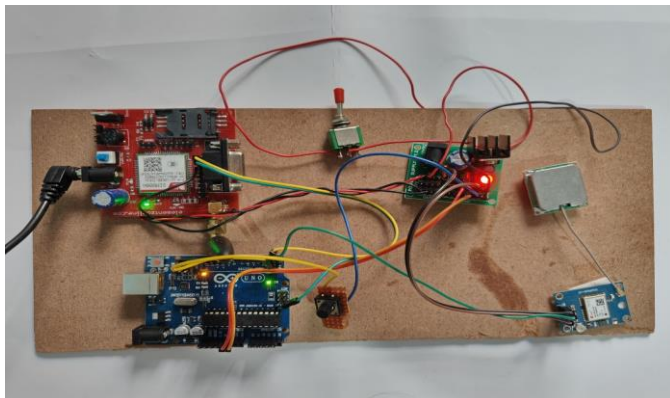

Fig 4 – Circuit Implementation

The system operates within a loop, where it continuously reads data from the GPS and GSM modules. When GPS data is received, it is processed to find out the device's current location. This location data is then compared with predefined geofence coordinates to detect if the device has crossed the boundary of the geofenced area. If the device enters or exits the geofenced area, a trigger is activated to send an SMS alert via the GSM module.

Overall, this system provides a flexible platform for tracking the location of a device and implementing geofencing functionality, which may be applied in various scenarios such as vehicle tracking, asset management, or personal safety applications. The modular based design allows for customization and scalability to meet specific project requirements.

5. RESULTS & DISCUSSION

A GSM, GPS and geofencing tracking system combines the functionalities of GSM (Global System for Mobile Communication) and GPS (Global Positioning System) technologies to track and monitor the location of assets, such as vehicles or individuals.

1. GPS Location Data: The primary output of a GPS tracking system is the location data obtained from the GPS module. This data includes latitude and longitude coordinates, which represent the precise geographic location of the tracked asset at any given time.

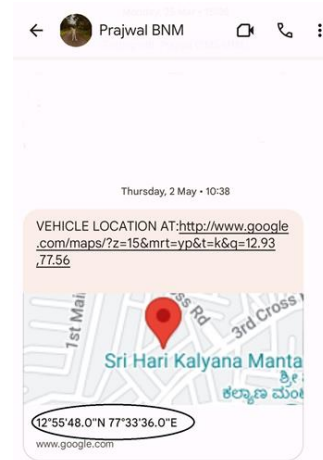

Fig -5: GPS Location Data

2. Timestamp: Along with the location data, GPS tracking systems often provide a timestamp indicating the time of location recording. This allows users to track the movement of the asset over time and determine its historical whereabouts

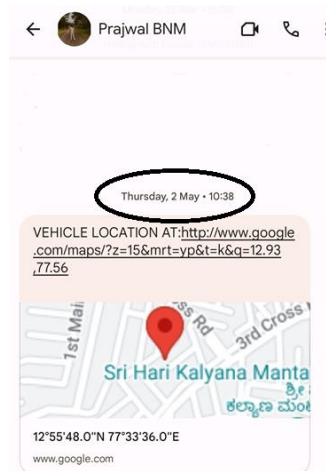

Fig -6: Timestamp

3. Speed and Direction: Some GPS tracking systems also provide further information such viz. speed and direction of the tracked asset. This data is useful for monitoring vehicle speed compliance or analyzing travel patterns

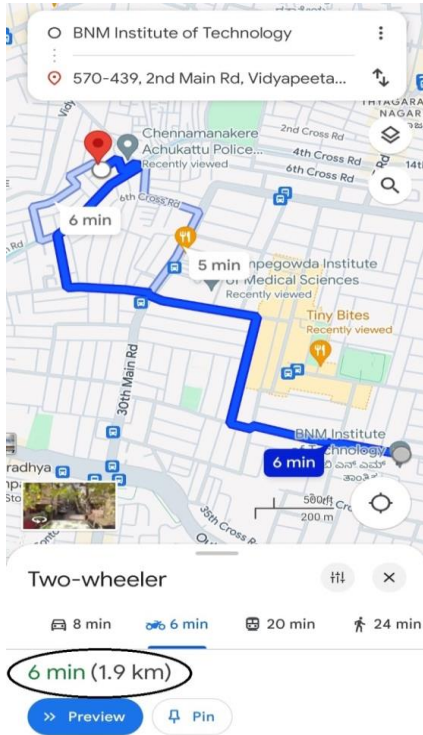

Fig -7 : Direction in Maps

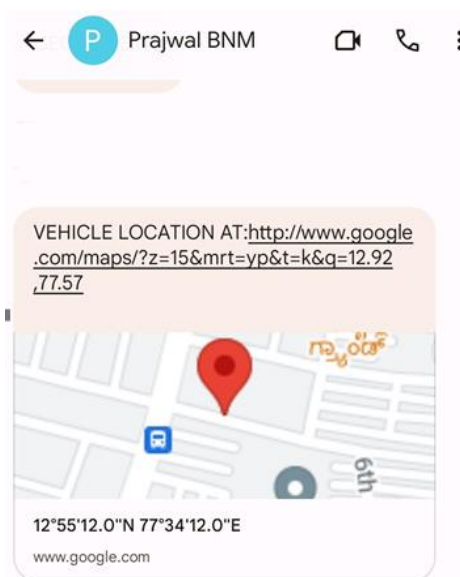

Fig -8: Real Time Vehicle Location using SMS

Fig 8 shows a text message with a location embedded in it. It contains a static map. The following is a explanation of how the GSM network facilitates the sending of an SMS message to a cellular phone:

1. User Initiates SMS: The process begins when a user decides to send SMS message from their device. They typically compose the message using the messaging application on their phone.

2. Message Routing: Once the user hits send, the message is processed by their mobile device. The device communicates with the nearest Base Transceiver Station (BTS), part of the Base Station Subsystem (BSS).

3. BTS Communication: The BTS receives the message from the mobile device and forwards the message to the Base Station Controller (BSC), which is responsible for managing multiple BTSs within its coverage area.

4. Network Handoff: The BSC then routes the message to the Mobile Switching Center (MSC), which is part of the Network Switching Subsystem (NSS). The MSC is responsible for switching and routing voice and data calls within the GSM network.

5. Message Delivery: At this point, the MSC determines the recipient's location based on their mobile phone number. If the recipient is within the same GSM network, the message is then routed directly to the MSC serving their current location.

6. Interconnection (If needed): If the recipient is on a different GSM network or located outside the home network coverage area, the MSC may need to communicate with other MSCs or external networks to reach the recipient's device.

7. Message Delivery to Recipient: Once the message reaches the MSC serving the recipient's location, it is delivered to the recipient's mobile device. The device receives the message and notifies the user of the new SMS.

8. Acknowledgment: The recipient's device sends an acknowledgment message back to the sender's device, confirming that the SMS was successfully received.

9. User Interaction: The recipient can then view the received SMS message on their device and choose to read, reply, or ignore it as desired.

Throughout this process, the GSM network ensures the reliable and timely delivery of the SMS message from the sender to the recipient's cellular phone, regardless of their location within the network coverage area.

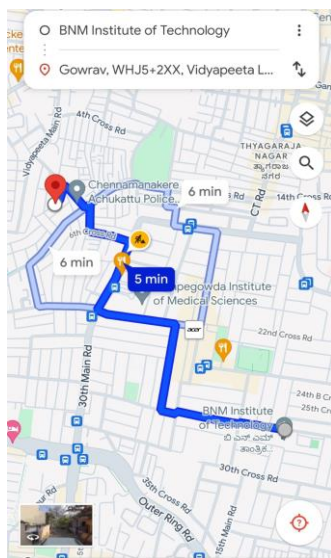

Fig -9: Real Time Vehicle Location using Maps

Fig 9 map centers on BNM Institute of Technology. Text labels on the map around BNM Institute of Technology include "Gowrav, WHJ5+2XX, Vidyapeeta". The map displays the distance to the destination from your current location, but the destination itself is not shown in the screenshot. In the bottom left corner of the image, it shows "6 min" next to "Chennamanakere Rd" which likely indicates the distance to Chennamanakere Rd along the route

4. CONCLUSIONS

In summary, the integration of GSM, GPS and geofencing technology into the location tracking system provides a solution for monitoring and controlling the instantaneous location of the equipment. While GPS modules provide accurate location management, GSM modules help transmit this information to a central server or database. A microcontroller is included for efficient operation and data flow control.

The utilization of geofencing algorithms allows creating virtual boundaries and triggering events when the device enters or leaves these areas. While central servers play a significant role in receiving, storing, and processing location data, the selected communication system also ensures efficient and secure transmission. To improve user experience, user interfaces can be designed to display and specify goals. Emphasize that power management is critical to extending the battery life of devices and that security measures must be taken to protect sensitive location data. The system's scalability, error handling mechanisms, and regulatory compliance further enhance its robustness. Essentially, the integrated system uses a combination of GSM, GPS and geofencing technology to provide for a versatile and effective solution for a range of applications, from asset tracking to personal security.

REFERENCES

- [1] Intelligent monitoring of wireless environment through collection of time and analytics by Satoko Itayaa, Fumiko Ohoria, Toru Osugaa, Takeshi Matsumuraa. The 14th International Conference on Environmental Systems, Networks and Technologies (ANT) will be held in Leuven, Belgium, on 15-17 March 2023.
- [2]. Limitations of location tracking in transmission By: Jay Stanley and Jennifer Stisa Granick April 8, 2020
- [3]. International Journal of Computer Science, Engineering and Applications (IJCSA), Pankaj Verma 1, J.S Bhatia 2. Vol.3, No.3, June 2013 DOI: 10.5121/ijcsea.2013.3304 33 Google design and Growth based on GPS-gsm Google design system-based evaluation.
- [4] Research on the application of GPS-based wireless communication system in highway landslides Zhiwen Xiongxiang J Wireless Communications Network (2021) 2021: 163
- [5] "Global Positioning System Wide Area Augmentation System (WAAS) Performance Standard" (PDF). p. B-3. Archived (PDF) from the original on April 27, 2017. Retrieved January 3, 2012.
- [6] Science Reference Section (November 19, 2019). "What is a GPS? How does it work?". Everyday Mysteries. Library of Congress. Archived from the original on April 12, 2022. Retrieved April 12, 2022.
- [7] McDuffie, Juquai (June 19, 2017). "Why the Military Released GPS to the Public". Popular Mechanics. Archived from the original on January 28, 2020. Retrieved February 1, 2020.
- [8] "Factsheets: GPS Advanced Control Segment (OCX)". Losangeles.af.mil. October 25, 2011. Archived from the original on May 3, 2012. Retrieved November 6, 2011.
- [9] Kastrenakes, Jacob (September 25, 2017). "GPS will be accurate within one foot in some phones next year". The Verge. Archived from the original on January 18, 2018. Retrieved January 17, 2018.
- [10] "GSM (2nd Generation Mobiles)". Engaging with Communications. Archived from the original on 30 January 2023. Retrieved 23 May 2023.
- [11] Motorola Demonstrates Long Range GSM Capability – 300% More Coverage with New Extended Cell. Archived 19 February 2012 at the Wayback Machine.