

# Intelligent Fault Classification in Transmission Lines Using Deep Learning Models

Venkatesh Daggupati<sup>1</sup>, Siva Nga Sai Jammula<sup>2</sup>

<sup>1</sup>Electrical Engineering at Texas Tech University, Lubbock, Texas, USA

<sup>2</sup>Electrical Engineering at Worcester Polytechnic Institute, Worcester, Massachusetts, USA

\*\*\*

**Abstract** - To provide stability and a continuous supply of power, the detection and classification of faults in the transmission lines (TLs) are critical and vital in this modern age. Ensuring the stability of power systems hinges on effective error detection and classification within transmission lines (TLs). While strategies like the Extreme Learning Machine (ELM) algorithm have demonstrated effectiveness, their adaptability to diverse error situations remains a concern. Prioritizing error variety is essential for enhancing adaptability to real-world conditions, finally reinforcing the resilience of the power grid.

Building upon the ELM algorithm, this undertaking advocates integrating deep learning techniques to improve error detection and classification in TLs. Through this approach, capitalizing on deep learning's capability to autonomously discern complex and detailed patterns, potentially leading to more exact and true defect identification. Additionally, the undertaking extends beyond algorithmic improvements to encompass growing and refining datasets, vital for enhancing error detection system dependability. Real-time implementation plans are moreover examined to evaluate adaptability in dynamic operational environments. By embracing error variety and harnessing deep learning, this assignment aims to deliver a sturdy and resilient and flexible defect detection and classification framework, poised to excel in real-world applications and enhance modern power system resilience.

**Key Words:** Fault Detection, Fault Classification, Deep Learning, Extreme Learning Machine (ELM), Fault Diversity, Power Systems stability

## 1. INTRODUCTION

In the present and existing era of Industry 4.0, the electrical power demand is rising continuously. To fulfill the demand, the number of power generation units is moreover growing. All these units are linked through a complicated power system network (PSN), which has essentially three important and significant components: power generation, transmission, and distribution. Power is transferred from one place to another place through the transmission lines. Reliable and stable operation of the power system is vital and crucial to minimizing its impacts on sector, business, transportation, and domestic sectors. One of the most crucial and vital aspects that hinder the continuous supply of electricity and power is an error in the power system.

In the present and existing era of Industry 4.0, the electrical power demand is growing continuously. To fulfill the demand, the number of power generation units is furthermore growing. All these units are linked through a complicated and intricate power system network (PSN), which has essentially three important and significant components: power generation, transmission, and distribution. Power is transferred from one place to another place through the transmission lines. Reliable and stable operation of the power system is necessary and fundamental to minimize its impacts on sector, business, transportation, and domestic sectors. One of the most significant and essential aspects that hinder the continuous supply of electricity and power is a defect in the power system. Most of the inquiry is completed in the domain of protective relaying of power systems. However, actuating the relay is time-consuming and this operation can be made quicker applying machine learning (ML). ML is broadly used in every aspect of life because of the availability of relevant data. Using available defect data such as error voltage and contemporary and ongoing a ML model can be trained to identify and sort new instances. In the area of power systems, researchers have concentrated on detecting and categorizing faults applying distinct Deep Learning (DL) and ML algorithms.

## 2. LITERATURE REVIEW

The literature on advanced defect detection in transmission lines presents a mixed and assorted array of methodologies and technologies aimed at bolstering power system dependability and resilience. Machine learning algorithms, incorporating support vector machines (SVMs), decision trees, and neural networks, have been thoroughly investigated for their effectiveness in error identification and classification.

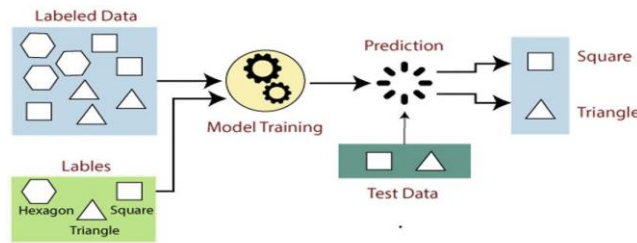

Figure 1: Scheme of supervised learning, showing labeled data used for model training and predictions on test data

SVMs, renowned for their capability to handle high-dimensional data and nonlinear connections, exhibit resilient defect detection performance by mapping input data into higher-dimensional spaces. Decision trees offer clear defect classification frameworks, assisting operators in understanding underlying decision-making procedures and fundamental defect detection features. Deep learning techniques, such as convolutional neural networks (CNNs) and recurrent neural networks (RNNs), demonstrate notable potential in error detection applications. CNNs excel in identifying sophisticated and multifaceted error patterns across dissimilar defect classes, especially in image recognition activities, while RNNs are adept at modeling sequential data and temporal dependencies for error prediction. Additionally, Extreme Learning Machines (ELM) have emerged as a hopeful and encouraging avenue for defect detection, characterized by their simplicity and fast learning abilities. Unlike conventional neural networks, ELM algorithms streamline training procedures, arising in enhanced generalization performance. Integrating Internet of Things (IoT) technologies with machine learning enables real-time defect detection by collecting data from transmission lines and analyzing it for anomalies. Advancements in detecting technologies, such as phasor measurement units (PMUs) and distributed sensors, contribute to enhanced defect detection and localization in smart grids. Renewable energy integration poses unique obstacles for error detection, requiring responsive and versatile algorithms capable of dynamically adjusting to changing grid dynamics. Innovations leveraging blockchain and augmented actuality enhance error detection system dependability and visualization during upkeep processes. Additionally, transfer learning techniques have been investigated to leverage existing knowledge and data for improved error detection abilities in transmission lines.

Figure 2: Illustration of SVM Classification in a Two-Dimensional Space

## 3. PROPOSED FRAMEWORK FOR FAULT DETECTION AND FAULT CLASSIFICATION

In this study, an innovative deep learning-based framework for transmission line error detection and classification has been

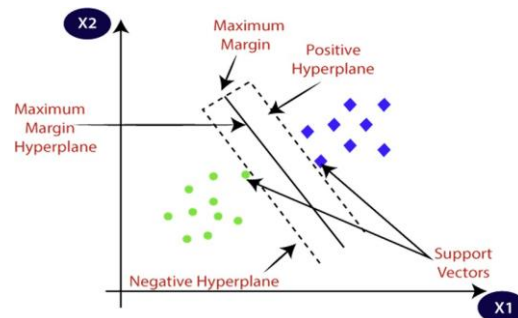

developed, as illustrated in Fig. 1. A long-distance transmission line system was modeled utilizing MATLAB/Simulink, comprising of synchronous machines, a 13.8/735 kV transformer, and various and several RLC loads linked through 300 km lines.

Using a programmable defect block, a broad range of faults was generated, comprising LG, LL, LLG, LLL, and LLLG, along with healthy conditions. The corresponding three-phase voltage and contemporary and ongoing waveforms were collected and saved. Fault data were captured at the time of the disturbance, while normal data were sampled under stable running conditions. The dataset was then split into training and testing sets, followed by min-max normalization to scale features within a corrected range. Finally, a Convolutional Neural Network (CNN) was trained for multiclass error classification, and the outcomes were compared with conventional and customary SVM and ELM models in conditions of accuracy, dependability, and computational intricacy. Each step of the framework is described in the subsequent subsections.

### 3.1 Transmission Line Modeling and Simulation

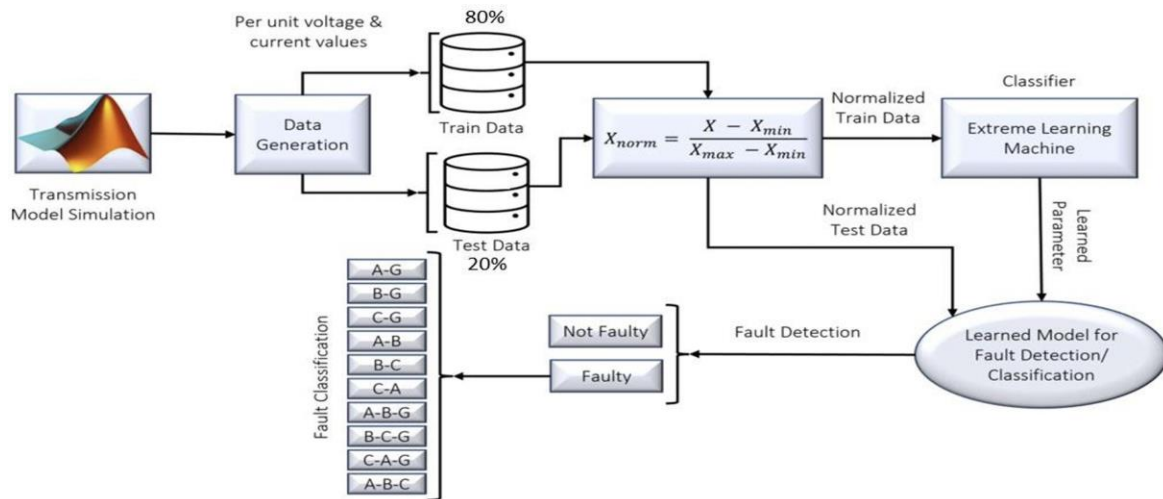

Figure 3: Proposed framework for fault detection and fault classification

The proposed framework was executed in MATLAB/Simulink, where two standard and normal transmission line (TL) configurations were modeled to reproduce realistic long-distance power transfer. These models represented systems in which energy generated in one region is communicated to distant loads. In real-life systems, loads are generally a combination of resistive (R), inductive (L), and capacitive (C) components; nonetheless, for simplicity, equivalent single RLC loads were evaluated in this study.

Table 1: MAIN SYSTEM PARAMETERS

Component	Parameters
Synchronous machine	6 × 350 MVA, 13.8 kV, initialized at 1500 MW
Transmission line	Three-phase, 300 km
Transformer	13.8/735 kV, 6 × 350 MVA
Source	30,000 MVA, 735 kV
Loads	100 MW, 330 MW, 250 MW

To increase system intricacy and realism, the two TL models were combined into a single integrated simulation block. This composite system included three generation units and four RLC loads, with each transmission line spanning 300 km. Faults of all important and significant types; single line-to-ground (LG), line-to-line (LL), double line-to-ground (LLG), three-phase (LLL), and three-phase-to-ground (LLLG); were triggered employing a programmable defect block. The block enabled control of error type, inception time, and location. The per-unit voltage and contemporary and ongoing waveforms were saved for every situation, offering data for further analysis.

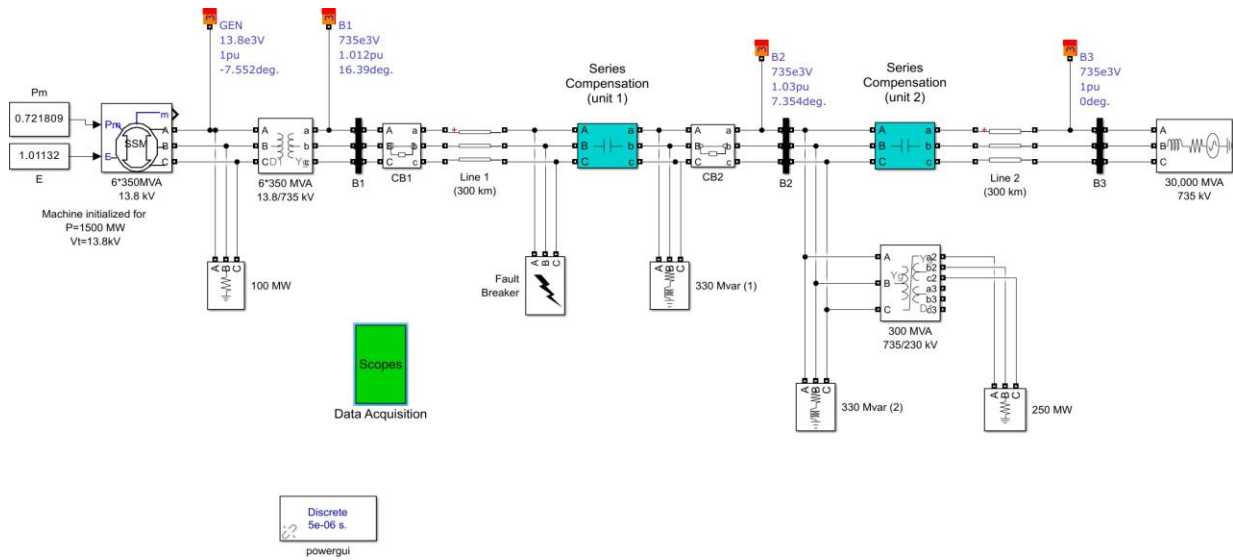

Figure 4: Simulink block model of the transmission line system featuring a connected fault block

The simulation ensured that the dataset captured both healthy and defective and flawed conditions. Fault data were recorded exactly at the disturbance intervals, while no-fault data were sampled at random under stable operation. Each generated sample consisted of six features: three per-unit phase voltages and three per-unit phase currents. This process produced a balanced dataset across all classes, covering a broad spectrum of running states. This structured simulation and data generation procedure guaranteed that the proposed framework had entry to a rich and mixed and assorted dataset, allowing the deep learning model to learn resilient error signatures applicable to real-world power system situations.

### 3.2 Data Collection and Preprocessing

The signals chosen for data collection were the three- phase voltages ( $V_a, V_b, V_c$ ) and currents ( $I_a, I_b, I_c$ ) from the transmission line model. The simulation was run for 0.2 seconds, long enough to capture both healthy operation and temporary responses during error events. Faulty waveforms were extracted at the instant of disturbance, while non-fault (healthy) data were sampled at random intervals under steady-state conditions.

To obtain the data, the measured signals were exported from Simulink scopes into the MATLAB workspace. Currents were saved under the variable  $I(xyz)$  and voltages as  $V(xyz)$  in a structured time-series format. These were then reorganized were retained for analysis. Each data segment was then labeled with its respective fault type. A numeric coding scheme was introduced to map classes to integer labels (e.g., No-Fault = 0, LLL = 1, LLLG = 2, LLG = 3, LG = 5, LL = 6, etc.), as illustrated in Table 1. This structured labeling allowed CNN to easily associate raw waveforms with their categories during training.

The dataset was subsequently preprocessed to enhance learning performance. Noise and discrepancies were removed during cleaning, and then min-max normalization was applied so that all features were mapped into the range [0,1].

Table 2: BINARY REPRESENTATION OF FAULT TYPES

Binary Code	Fault Type
0 0 0 0	No Fault
1 0 0 1	LG fault (Between Phase A and Ground)
1 0 1 0	LG fault (Between Phase B and Ground)
1 1 0 0	LG fault (Between Phase C and Ground)
0 0 1 1	LL fault (Between Phase A and Phase B)
0 1 1 0	LL fault (Between Phase B and Phase C)
0 1 0 1	LL fault (Between Phase C and Phase A)
1 0 1 1	LLG fault (Between Phases A, B and Ground)
1 1 1 0	LLG fault (Between Phases B, C and Ground)
1 1 0 1	LLG fault (Between Phases C, A and Ground)
0 1 1 1	LLL fault (Between all three phases)
1 1 1 1	LLLG fault (Three-phase symmetrical fault)

This step was necessary and fundamental to avoid scale bias and ensure uniform contribution of all features. The mathematical representation is:

$$x' = \frac{x - x_{min}}{x_{max} - x_{min}}$$

where X is the original feature, and Xmin, Xmax are the minimum and maximum values of that feature. The final dataset was balanced across all classes (10 fault types + 1 no-fault) to prevent bias toward any single category. For training and evaluation, the dataset was partitioned into 80.

By following this thorough and meticulous pipeline; signal extraction, temporary separation, labeling, normalization, and balanced partitioning; the prepared dataset supplied a strong and durable foundation for training the CNN. This ensured that the classifier could generalize effectively to invisible fault situations and deliver high-accuracy defect detection and classification.

Epoch	Iteration	Time Elapsed (hh:mm:ss)	Mini-batch Accuracy	Validation Accuracy	Mini-batch Loss	Validation Loss	Base Learning Rate
1	1	00:00:11	6.25%	14.50%	2.2794	7.0991	0.0010
1	50	00:00:17	100.00%	99.67%	0.0050	0.0811	0.0010
1	100	00:00:22	100.00%	100.00%	0.0119	0.0396	0.0010
1	150	00:00:27	100.00%	100.00%	0.0130	0.0266	0.0010
1	200	00:00:33	100.00%	100.00%	0.0083	0.0198	0.0010
2	250	00:00:38	100.00%	100.00%	0.0017	0.0162	0.0010
2	300	00:00:43	100.00%	100.00%	0.0018	0.0141	0.0010
2	350	00:00:49	100.00%	100.00%	0.0081	0.0132	0.0010
2	400	00:00:55	100.00%	100.00%	0.0162	0.0127	0.0010
2	450	00:01:00	100.00%	100.00%	0.0083	0.0107	0.0010
3	500	00:01:06	100.00%	100.00%	0.0038	0.0103	0.0010
3	550	00:01:12	100.00%	100.00%	0.0004	0.0109	0.0010
3	600	00:01:17	100.00%	99.89%	0.0017	0.0124	0.0010
3	650	00:01:22	100.00%	100.00%	0.0014	0.0083	0.0010
4	700	00:01:28	100.00%	100.00%	0.0002	0.0086	0.0010
4	750	00:01:34	100.00%	100.00%	0.0004	0.0088	0.0010
4	800	00:01:40	100.00%	100.00%	0.0019	0.0088	0.0010
4	850	00:01:46	100.00%	100.00%	0.0054	0.0070	0.0010
4	900	00:01:51	100.00%	100.00%	0.0028	0.0070	0.0010
5	950	00:01:56	100.00%	100.00%	0.0008	0.0075	0.0010
5	1000	00:02:01	100.00%	99.89%	0.0001	0.0093	0.0010
5	1050	00:02:07	100.00%	99.89%	0.0006	0.0097	0.0010
5	1100	00:02:12	100.00%	99.89%	0.0009	0.0097	0.0010
5	1150	00:02:17	100.00%	100.00%	0.0006	0.0057	0.0010
6	1200	00:02:23	100.00%	100.00%	6.2554e-05	0.0062	0.0010
6	1250	00:02:28	100.00%	100.00%	0.0002	0.0070	0.0010
6	1300	00:02:33	100.00%	100.00%	0.0008	0.0073	0.0010
6	1350	00:02:38	100.00%	100.00%	0.0027	0.0042	0.0010
6	1400	00:02:43	100.00%	100.00%	0.0013	0.0053	0.0010
7	1450	00:02:48	100.00%	100.00%	0.0003	0.0061	0.0010
7	1500	00:02:53	100.00%	99.72%	5.7221e-05	0.0086	0.0010
7	1550	00:02:58	100.00%	99.89%	0.0003	0.0082	0.0010
8	1600	00:03:04	100.00%	100.00%	0.0003	0.0041	0.0010
8	1650	00:03:09	100.00%	100.00%	2.8828e-05	0.0046	0.0010
8	1700	00:03:14	100.00%	100.00%	8.4625e-05	0.0058	0.0010
8	1750	00:03:19	100.00%	99.94%	0.0004	0.0064	0.0010
8	1800	00:03:24	100.00%	100.00%	0.0015	0.0027	0.0010
9	1850	00:03:29	100.00%	100.00%	0.0009	0.0045	0.0010
9	1900	00:03:35	100.00%	100.00%	0.0001	0.0050	0.0010
9	1950	00:03:40	100.00%	99.72%	4.4102e-05	0.0082	0.0010
9	2000	00:03:45	100.00%	99.89%	0.0002	0.0075	0.0010
9	2050	00:03:50	100.00%	100.00%	0.0003	0.0031	0.0010
10	2100	00:03:55	100.00%	100.00%	1.7921e-05	0.0038	0.0010
10	2150	00:04:00	100.00%	100.00%	7.0421e-05	0.0051	0.0010
10	2200	00:04:06	100.00%	100.00%	0.0003	0.0060	0.0010
10	2250	00:04:11	100.00%	100.00%	0.0010	0.0021	0.0010
					0.0007	0.0043	0.0010

Training finished: Max epochs completed.

Figure 5: Working of epochs during CNN training

### 3.2 Deep Learning Model Design

The proposed framework employs a Convolutional Neural Network (CNN) as the central deep learning architecture to detect and categorize transmission line faults. CNNs were selected because of their superior capability to capture spatial and temporal correlations within multivariate electrical signals, permitting the network to learn fault-specific patterns directly from the raw voltage and contemporary and ongoing inputs. Unlike standard procedures, which depend heavily on manual feature extraction, CNNs automatically recognize hierarchical features that distinguish error categories with minimal preprocessing effort.

The CNN architecture consists of the following layers:

- Input Layer:** Receives six normalized features per sample (three-phase voltages and three-phase currents).
- Convolutional Layers:** Apply several filters to detect localized patterns such as abrupt drops in voltage or surges in current triggered by faults. These filters slide across the input, making feature maps that highlight distinctive electrical behaviors.
- Pooling Layers:** Max pooling was utilized after convolutional layers to reduce the dimensionality of feature maps,

suppress noise, and improve invariance to small signal changes. This reduces computational intricacy while maintaining the most significant and essential features.

4. **Fully Connected Layers:** High-level reasoning layers that integrate features from earlier stages and learn non-linear combinations for classification.

5. **SoftMax Output Layer:** Produces probability distributions over all defect types (10 error categories +1 no-fault), assigning the most anticipated class label for each sample.

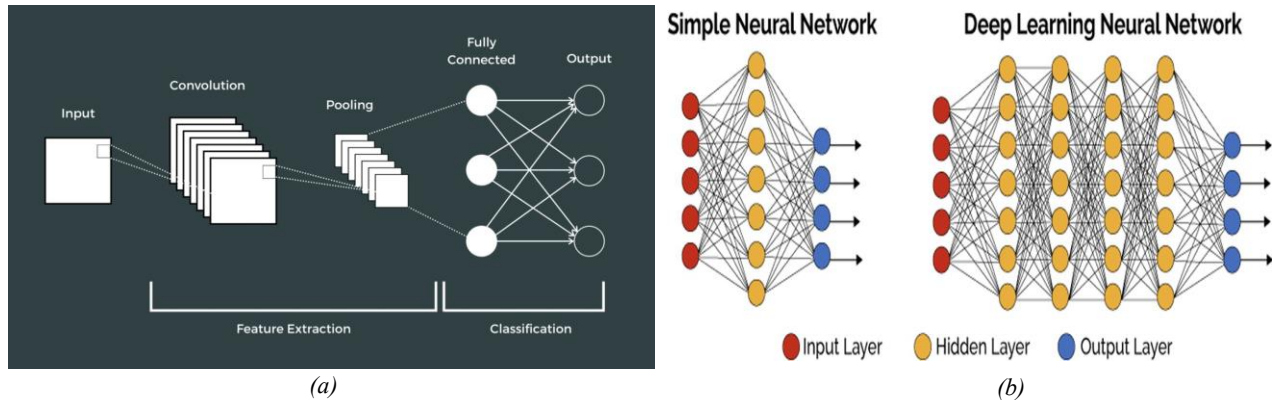

Figure 6: (a) Convolutional Neural Network for Fault Detection and Classification. (b) Comparison of simple neural network and deep learning neural network architectures.

For training, the dataset was divided into 80% training and 20% testing subsets, with a portion of the training data used for validation. The model was optimized by applying the Adam optimizer with a learning rate tuned for stability, a mini-batch size of 32, and 10 epochs of training. During training, the model parameters were updated applying backpropagation and gradient descent, minimizing the cross-entropy loss between predicted and true class labels. Performance observation was carried out in genuine time by monitoring accuracy and loss curves. As training progressed, the accuracy increased consistently while the loss decreased, confirming the CNN’s capability to meet effectively. Validation inspections were integrated to detect overfitting. After training, predictions were generated for the test set and assessed applying a confusion matrix, which revealed near-perfect classification across error kinds. The model further demonstrated high dependability through ROC curve analysis, generating an area under the curve (AUC) of 0.94.

Overall, CNN accomplished a classification accuracy of 98.9%, compared to 84.9% for SVM, presenting its superiority in capturing error variety. By integrating convolutional filters, pooling, and nonlinear reasoning, the CNN model supplied a robust, scalable, economical and cost-effective instrument for real-time error detection and classification in power transmission systems.

### 3.3 Performance Evaluation

The proposed CNN framework was evaluated utilizing a thorough set of statistical performance measures. These included classification accuracy, precision, recall, F1-score, confusion matrix analysis, and Receiver Operating Characteristic (ROC) curve evaluation. Together, these metrics ensured both worldwide and class-wise evaluation of the error detection and classification task.

The accuracy (Acc) was calculated as the proportion of correctly classified samples to the total number of samples:

$$Acc = \frac{TP + TN}{TP + TN + FP + FN}$$

where TP, TN, FP and FN represent true positives, true negatives, false positives, and false negatives, respectively. Precision (P) and recall (R) were employed to evaluate the model’s ability to correctly detect faulty states and avoid false alarms:

$$P = \frac{TP}{TP+FP} \quad R = \frac{TP}{TP+FN}$$

The F1-score, which balances precision and recall, was computed as the harmonic meaning of the two:

$$F_1 = \frac{2 \cdot P \cdot R}{P + R}$$

These equations provide a full and comprehensive statistical perspective, notably in multiclass classification where specific defect kinds are more tough and arduous to detect.

The confusion matrix revealed that the CNN achieved nearly perfect classification across all 11 categories (10 fault types + no-fault), with very few misclassifications. In comparison, the SVM baseline model exhibited notable confusion among unsymmetrical faults such as LG and LLG. To further validate robustness, ROC curves were plotted for each class, and the overall area under the curve (AUC) was measured at 0.94, demonstrating strong generalization and high sensitivity across fault categories.

From a numerical standpoint, the CNN attained a classification accuracy of 98.9%, substantially greater than the 84.9% obtained by SVM. High precision, recall, and F1-scores across all error classes verified the CNN’s dependability in differentiating symmetrical (LLL, LLLG) and unsymmetrical (LG, LL, LLG) faults. Additionally, training and validation curves were analyzed to track convergence. The training accuracy increased consistently over 10 epochs, while both training and validation losses decreased, indicating stable learning without overfitting. This trend validated that the CNN successfully generalized to invisible test data while maintaining robustness.

Overall, the evaluation demonstrated that the proposed CNN framework is a sturdy and resilient, scalable, and productive and effective instrument for real-time defect detection and classification in modern power transmission systems, outperforming traditional machine learning procedures in both accuracy and consistency.

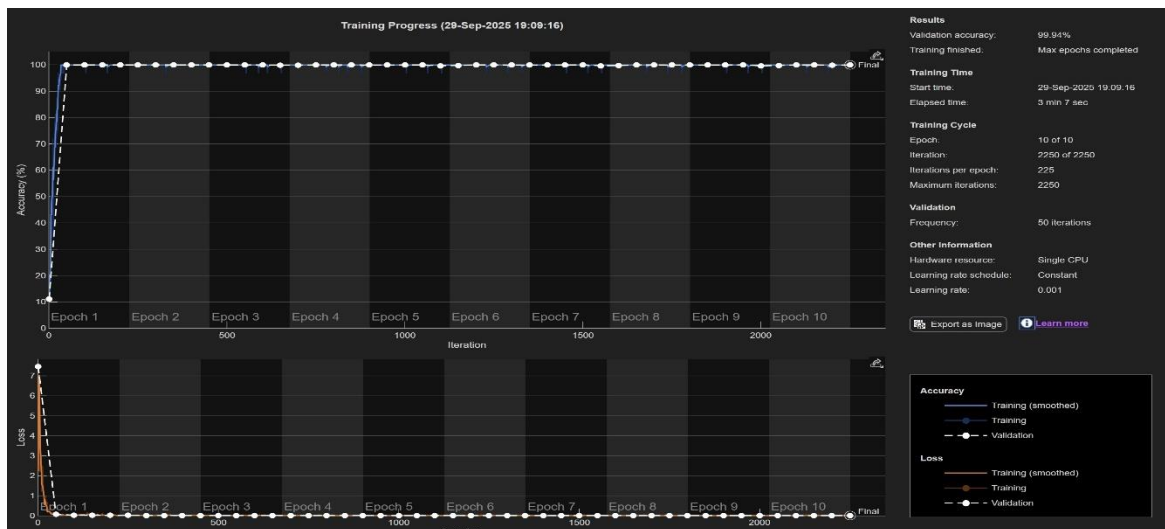

Figure 7: Training progress of the CNN model for fault detection and classification

## RESULTS AND ANALYSIS

The proposed CNN-based framework was confirmed applying MATLAB/Simulink simulations and assessed through comparative experiments with traditional classifiers. The out- comes are presented in four aspects: waveform analysis, CNN training results, statistical metrics, and comparative evaluation.

1) Simulation Results: The transmission line model produced three-phase voltage and contemporary and ongoing signals under both healthy and imperfect and malfunctioning conditions. Each error type demonstrated unique transient features. For instance, during a single line-to-ground (LG) defect, the faulted phase voltage collapsed to almost zero, while the corresponding current rose sharply. In the case of line-to-line (LL) faults, the two involved phase voltages were distorted while the unaffected phase remained almost unaltered. Double line-to-ground (LLG) faults combined these traits with

elevated ground current. Three-phase (LLL) faults produced a concurrent collapse of all three phase voltages, with symmetrical contemporary and ongoing rise across all stages. For three-phase-to-ground (LLLG) faults, both voltage collapse and heavy present distortion happened.

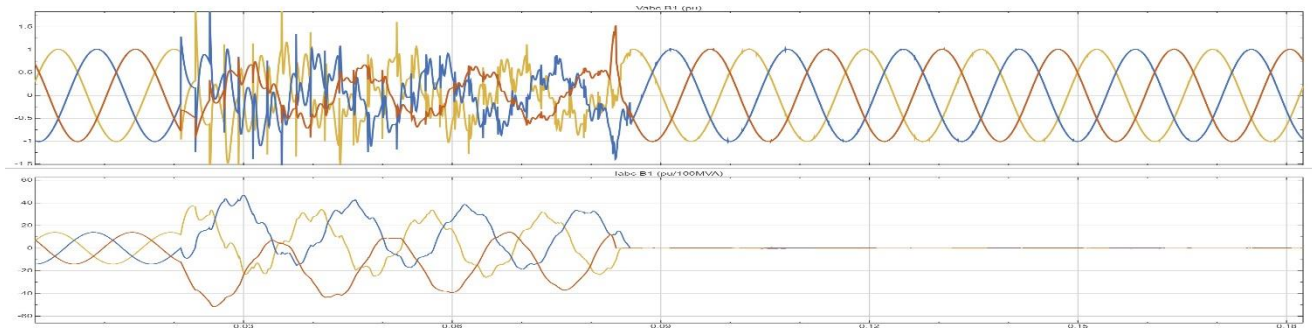

Figure 8: Voltage and current waveforms of a three-phase line fault

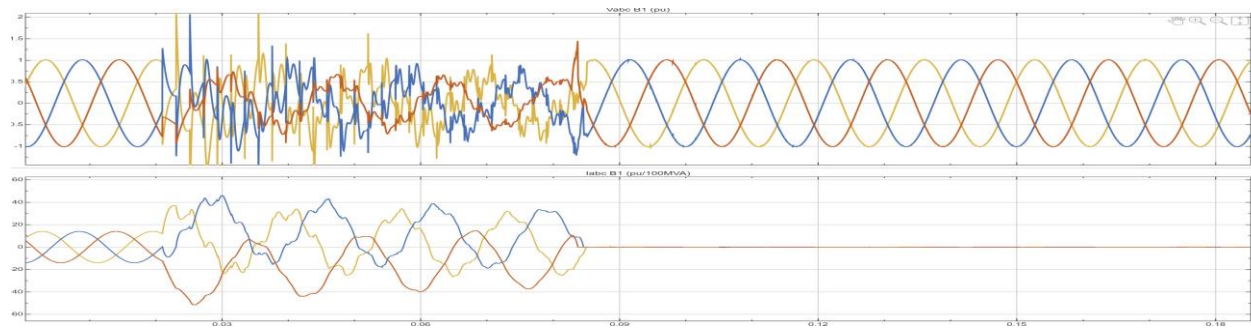

Figure 9: Voltage and current waveforms of a three-phase line-to-ground fault

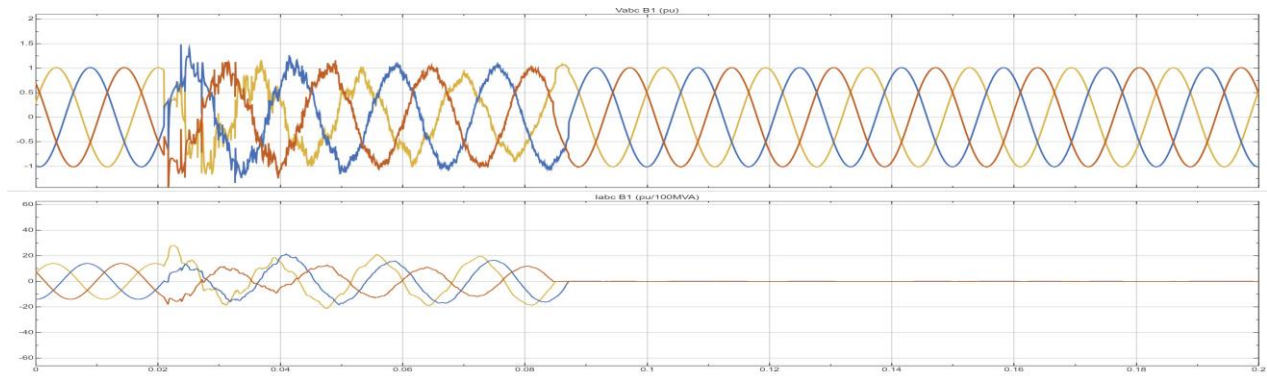

Figure 10: Voltage and current waveforms of a line-to-ground (LG) fault in a three-phase transmission line.

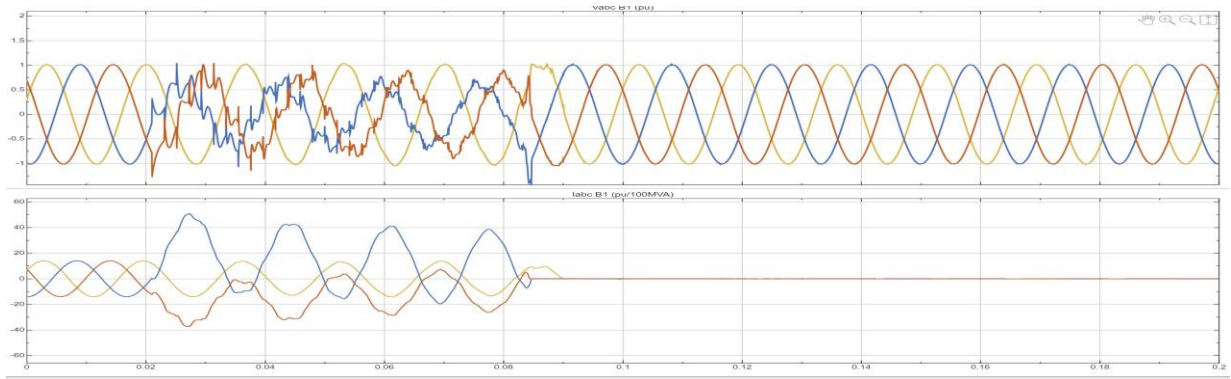

Figure 11: Voltage and current waveforms of a line-to-line (LL) fault in a three-phase transmission line.

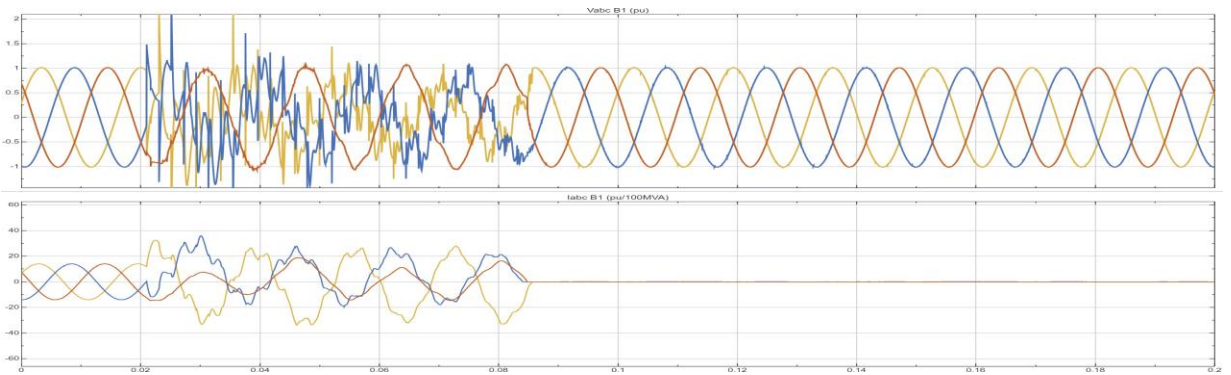

Figure 12: Voltage and current waveforms of a double line-to-ground (LLG) fault in a three-phase transmission line

- CNN Training and Outputs:** CNN was trained employing **80%** of the dataset and tested on **20%**. Training was conducted with the Adam optimizer, a mini-batch size of 32, and 10 epochs. Accuracy and loss curves validated stable convergence: training accuracy rose consistently, while training and validation losses decreased consistently, indicating no overfitting.

The confusion matrix validated that the CNN accomplished near-perfect classification across all 11 types (10 defect categories +no defect), with sole minor confusion recorded between closely related unsymmetrical faults (LG vs. LLG). Per-class accuracy exceeded **95%**, demonstrating robust generalization. Receiver Operating Characteristic (ROC) curves further validated the model's performance, generating an area under the curve (AUC) of 0.94.

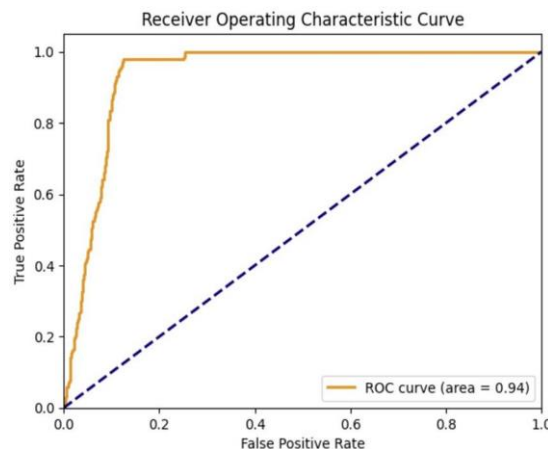

Figure 12: ROC Curve for CNN-based fault detection

3. **Statistical Evaluation Metrics:** The performance of the CNN was quantified employing standard metrics: accuracy, precision, recall, and F1-score. CNN accomplished an overall classification accuracy of **98.9%**, compared to **84.9%** for the Support Vector Machine (SVM). Precision and recall values remained above **95%** across all classes, and F1-scores exceeded 0.95, confirming reliable and balanced performance. The confusion matrix highlighted that the CNN effectively classified symmetrical faults (LLL, LLLG) with nearly **100%**.
4. **Comparative Analysis:** To benchmark performance, the CNN was compared with SVM and Extreme Learning Machine (ELM) classifiers. The SVM achieved 84.9% accuracy but frequently misclassified LG and LLG faults due to

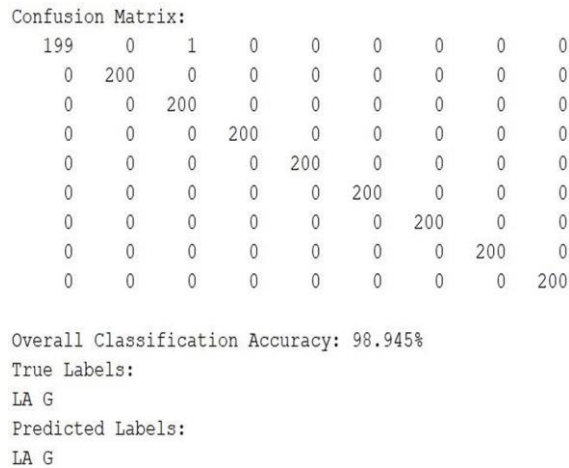

Figure 13: Confusion matrix of the proposed CNN model

overlapping transient features. The ELM showed moderate improvements but required significant manual features, extraction and preprocessing.

Table 3: COMPARISON OF SVM AND CNN MODEL PERFORMANCE

Model	Validation Accuracy	Loss
SVM	84.89%	0.1511
CNN (Proposed)	98.94%	0.0106

By contrast, the CNN automatically extracted hierarchical features from raw voltage and present and existing signals, removing the need for handcrafted inputs. Its convolutional layers identified localized distortions, pooling layers filtered noise while maintaining primary and principal error traits, and fully linked layers supplied resilient classification. This permitted the CNN to surpass both SVM and ELM in conditions of accuracy, precision, recall, and F1-score, while minimizing preprocessing effort.

5. **Discussion and Insights:** The superior performance of the CNN can be linked to its capability to capture both spatial correlations (phase-to-phase interactions) and temporal dynamics (defect transients). Unlike conventional techniques, CNN adjusts to diverse running conditions without manual intervention. From a pragmatic perspective, the outcomes verify that the CNN-based framework is appropriate and fitting for real-time deployment in smart grid environments. Its high classification accuracy, 98.9%, dependability across all classes, and reduced preprocessing necessities make it a hopeful and encouraging instrument for intelligent defect tracking systems. By permitting quick and fast and precise and correct classification of symmetrical and unsymmetrical faults, the framework can contribute to improved grid stability, minimized outage periods, and enhanced resilience of modern power systems.

#### 4. CONCLUSION

The Paper explores the usage of neural networks as an alternative approach for detecting and categorizing faults on transmission lines. The approaches utilized make application of the phase voltage and phase currents as inputs to the neural

networks. Various classes of faults, comprising single line-ground, line-line, double line-ground, and three-phase faults, are assessed in this study. The developed CNN model shows a remarkable and extraordinary defect classification accuracy of 98.9%, exceeding the performance of the earlier used support vector machine (SVM) model. This notable improvement highlights the superiority of deep learning methodologies, especially CNN architectures, in precisely discerning and categorizing faults within power systems.

The study used MATLAB-SIMULINK to simulate the whole and complete power transmission line model and generate the training dataset. The deep learning toolbox was thoroughly used to train and evaluate the performance of neural networks. Overall, this inquiry paves the way for further exploration and refinement of neural network techniques, driving continuous improvement in error detection systems and guaranteeing the stability and resilience of power networks.

## 5. FUTURE SCOPE

As a possible extension to this work, future inquiries could delve into the exploration of ensemble learning techniques to amalgamate numerous and manifold CNN models or alternative machine learning algorithms for the purpose of defect detection and classification. Furthermore, the integration of anomaly detection methodologies alongside traditional defect classification techniques may bolster the system's capability to identify earlier invisible or infrequent faults. Additionally, the development of a user-friendly interface or dashboard for system operators to imagine and interpret the results of the error detection system in real-time could streamline decision-making procedures and upkeep methods. These routes present convincing prospects for advancing the effectiveness and usability of defect detection systems in transmission lines.

## REFERENCES

- [1] J. C. A. Freire, A. R. G. Castro, M. S. Homci, B. S. Meiguins, and J. M. de Morais, "Transmission line fault classification using hidden Markov models," *IEEE Access*, vol. 7, pp. 113499–113510, 2019.
- [2] J. J. Morais, Y. Pires, C. Cardoso, and A. Klautau, "A framework for evaluating automatic classification of underlying causes of disturbances and its application to short circuit faults," *IEEE Transactions on Power Delivery*, vol. 25, no. 4, pp. 2083–2094, 2010.
- [3] M. I. Zaki, R. A. El Sehiemy, G. M. Amer, and F. M. A. El Enin, "Sensitive/stable complementary fault identification scheme for overhead transmission lines," *IET Generation, Transmission & Distribution*, vol. 13, no. 15, pp. 3252–3263, 2019.
- [4] A. Aleem, N. Shahid, and I. H. Naqvi, "Methodologies in power systems fault detection and diagnosis," *Energy Systems*, vol. 6, no. 1, pp. 85–108, 2015.
- [5] M. O. F. Goni, M. Nahiduzzaman, M. S. Anower, M. M. Rahman, M. R. Islam, M. Ahsan, J. Haider, and M. Shahjalal, "Fast and accurate fault detection and classification in transmission lines using extreme learning machine," *PRIME*, 2023, doi: 10.1016/j.prime.2023.100107.
- [6] V. Daggupati, "Power quality disturbance classification in IEEE 9-bus system using STFT and deep learning," Doctoral dissertation, Texas Tech University, 2025. [Online]. Available: <https://hdl.handle.net/2346/103168>
- [7] K. Chen, J. Hu, Y. Zhang, Z. Yu, and J. He, "Fault location in power distribution systems via deep graph convolutional networks," *IEEE Journal on Selected Areas in Communications*, vol. 38, no. 1, pp. 119–131, 2019.
- [8] A. Saber, A. Emam, and H. Elghazaly, "A backup protection technique for three-terminal multisection compound transmission lines," *IEEE Transactions on Smart Grid*, vol. 9, no. 6, pp. 5653–5663, 2017.
- [9] H. Tong, R. C. Qiu, D. Zhang, H. Yang, Q. Ding, and X. Shi, "Detection and classification of transmission line transient faults based on graph convolutional neural network," *CSEE Journal of Power and Energy Systems*, vol. 7, no. 3, pp. 456–471, 2021.
- [10] M. F. Guo, N. C. Yang, and W. F. Chen, "Deep-learning-based fault classification using Hilbert–Huang transform and convolutional neural network in power distribution systems," *IEEE Sensors Journal*, vol. 19, no. 16, pp. 6905–6913, 2019.
- [11] M. M. Tawfik and M. M. Morcos, "ANN-based techniques for estimating fault location on transmission lines using Prony method," *IEEE Transactions on Power Delivery*, vol. 16, no. 2, pp. 219–224, 2001.
- [12] V. Daggupati and S. N. S. Jammula, "Recent advances in fault diagnosis techniques for high voltage transmission lines: A review," *International Journal of Recent Trends in Multidisciplinary Research*, vol. 2, no. 6, pp. 284–292, Mar.–Apr. 2026, doi: 10.59256/ijrtmr.20260602040.
- [13] J. Ma et al., "An intelligent classification framework for complex PQDs using optimized KS-transform and multiple fusion

CNN," IEEE Transactions on Industrial Informatics, vol. 20, pp. 1776–1785, 2023.

[14] H. Meena, H. K. Meena, and D. Saxena, "Classification of power quality disturbances with DWT based effective feature extraction," in Proceedings of the 4th International Conference on Recent Trends in Computer Science and Technology (ICRTCST), IEEE, 2022.

[15] S. Pan et al., "Classification of power quality disturbances using ResNet with channel attention mechanism," arXiv preprint arXiv:2407.04739, 2024.

[16] A. Akhileshwari, D. Venkatesh, M. Narasa Babu, G. Nikson Paul, and S. Ravindra, "Speed control of BLDC motor using LUO converter."

[17] R. R. Selvaraju et al., "Grad-CAM: Visual explanations from deep networks via gradient-based localization," International Journal of Computer Vision, vol. 128, pp. 336–359, 2020.