

Design and Implementation of a Solar-Tracked Wireless Hybrid Charging Station for Electric Vehicles

Rupali Patel , Deenu Kumar karsh , Rahul Manhar , Manisha , Prof. Richa Dubey

Dept of EEE Chouksey Engineering College Bilaspur (CG)

Dept of EEE Chouksey Engineering College Bilaspur (CG)

Dept of EEE Chouksey Engineering college Bilaspur (CG)

Dept of EEE Chouksey Engineering College Bilaspur (CG)

Department of EEE , Chouksey Engineering College Bilaspur CG. India

Abstract - The rapid growth of electric vehicles has significantly increased the demand for efficient, sustainable, and user-friendly charging infrastructure. Conventional wired charging systems often suffer from limitations such as mechanical wear, safety concerns, and inconvenience due to physical connections. To address these challenges, this paper presents the design and implementation of a solar-tracked wireless hybrid charging station for electric vehicles.

The proposed system integrates multiple subsystems, including solar energy harvesting, automatic solar tracking, battery storage, and wireless power transfer. Two solar panels connected in parallel are mounted on a dynamic tracking mechanism that utilizes Light Dependent Resistors (LDRs) and DC geared motors to continuously align the panels with the direction of maximum sunlight. This enhances the overall energy conversion efficiency compared to fixed solar installations.

The harvested energy is stored in a lithium-ion battery through a TP4056 charging module, which ensures safe charging with over-voltage and over-current protection. In addition to solar charging, the system incorporates a hybrid charging feature that allows the battery to be charged using a regulated 5V external power supply during low or no sunlight conditions, thereby ensuring uninterrupted operation.

The stored energy is transmitted wirelessly using an XKT-412 module based on inductive coupling. Power transfer is demonstrated using transmitter and receiver coils, with an LED used as an output indicator at the receiver side. Experimental results show successful wireless power transfer at short distances, validating the feasibility of the system.

The proposed model offers a cost-effective, eco-friendly, and scalable solution for future electric vehicle charging systems

by combining renewable energy sources with wireless power transfer technology.

Key Words: Wireless Power Transfer, Solar Tracking, Electric Vehicle Charging, Hybrid System, Inductive Coupling, TP4056

1. INTRODUCTION

With the increasing adoption of electric vehicles worldwide, the need for efficient and sustainable charging infrastructure has become more critical than ever. Traditional wired charging systems, although widely used, present several challenges such as cable management issues, risk of electric shock, wear and tear of connectors, and lack of convenience. Wireless power transfer (WPT) technology has emerged as a promising alternative that eliminates the need for physical connections and enhances user convenience.

This paper proposes a solar-powered wireless hybrid charging system designed specifically for electric vehicle applications. The system utilizes solar energy as the primary source of power, thereby reducing dependence on conventional grid electricity and promoting environmental sustainability. To maximize the efficiency of solar energy harvesting, an automatic solar tracking mechanism is incorporated.

The solar tracking system uses Light Dependent Resistors (LDRs) to sense the intensity of sunlight and adjust the orientation of the solar panels accordingly using N20 geared motors. This ensures that the panels remain aligned with the sun throughout the day, resulting in improved energy generation.

The generated electrical energy is stored in a 3.7V lithium-ion battery using a TP4056 charging module, which provides regulated and safe charging. The stored energy is then

utilized by a wireless power transfer module (XKT-412), which transmits power through electromagnetic induction.

At the receiver side, a coil captures the transmitted energy and converts it back into electrical form. This is demonstrated using a Light Emitting Diode (LED), which glows when sufficient power is received. The system is capable of transferring power wirelessly over a small air gap, demonstrating its practical feasibility.

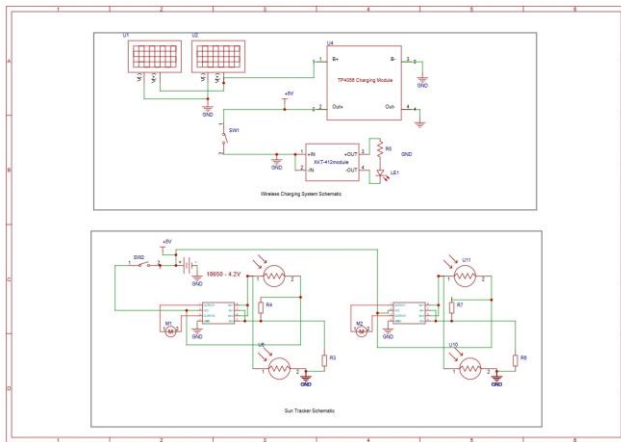

Fig-1: Schematic of a Solar-Tracked Wireless Hybrid Charging Station for Electric Vehicles

To ensure continuous operation, a hybrid charging mechanism is also included. When solar energy is insufficient or unavailable, the battery can be charged using an external AC supply via a regulated DC source. This enhances the reliability and usability of the system under varying environmental conditions.

Overall, the proposed system integrates renewable energy, automation, and wireless technology into a compact and efficient solution for next-generation electric vehicle charging.

2. LITERATURE REVIEW

Various research studies have explored wireless power transfer as an alternative to conventional charging methods for electric vehicles. Inductive coupling techniques have been widely used due to their simplicity and effectiveness in short-range energy transmission. Several works have also focused on improving efficiency through coil design, alignment optimization, and frequency control. These studies highlight the potential of wireless charging in reducing dependency on physical connectors and enhancing safety.

In addition, solar-based charging systems have gained significant attention for their ability to provide sustainable energy solutions. Solar tracking mechanisms using light sensors have been shown to increase energy generation efficiency compared to fixed panels. However, limited work has been done on integrating solar tracking with wireless charging and hybrid backup systems. This paper aims to bridge that gap by combining these technologies into a single system.

3. SYSTEM ARCHITECTURE

The proposed system consists of four main sections: solar energy generation, solar tracking mechanism, energy storage, and wireless power transfer. The solar generation unit includes photovoltaic panels connected in parallel to increase current output. These panels are mounted on a movable structure controlled by a tracking mechanism that adjusts their orientation based on sunlight intensity.

The energy storage unit consists of a lithium ion battery connected through a charging module that regulates voltage and current. The stored energy is supplied to the wireless transmission unit, which transfers power to a receiver coil through electromagnetic induction. A hybrid input is also provided to allow charging through an external power source when solar energy is unavailable. The overall architecture ensures efficient energy flow and continuous operation.

4. COMPONENT DESCRIPTION

The system utilizes various electronic and mechanical components to achieve its functionality. Solar panels are used to convert sunlight into electrical energy, while light dependent resistors act as sensors to detect light intensity. DC geared motors are employed to rotate the solar panel structure for tracking purposes, ensuring maximum exposure to sunlight.

A lithium ion battery is used for energy storage, supported by a charging module that provides safe and controlled charging. The wireless power transfer module enables contactless energy transmission using inductive coupling between transmitter and receiver coils. Additional components such as resistors, diodes, and switches are used to regulate current, protect the circuit, and control system operation.

5. WORKING PRINCIPLE

The working of the system begins with solar energy generation, where photovoltaic panels convert sunlight into electrical power. The solar tracking mechanism continuously

monitors light intensity using sensors and adjusts the panel position through motor control to maximize energy absorption. This dynamic alignment significantly improves the efficiency of the system compared to fixed installations.

Solar Power:

$$P=V \times I$$

The output power of the solar panel depends on voltage and current. The tracking mechanism increases current output by maintaining optimal alignment with sunlight.

Wireless Power concept:

$$V \text{ induced} \propto 1/d$$

The induced voltage in the receiver coil decreases with increasing distance, which affects the efficiency of wireless power transfer.

The generated energy is stored in a rechargeable battery through a charging module. Once stored, the energy is supplied to a wireless transmitter circuit that produces an alternating magnetic field. This field induces a voltage in the nearby receiver coil, enabling wireless power transfer.

The received energy is used to power a load, demonstrating the effectiveness of the system. In the absence of sunlight, the hybrid charging feature allows the battery to be charged using an external power source.

6. RESULTS AND DISCUSSION

The system was experimentally tested to evaluate its performance under different operating conditions. It was observed that the LED intensity decreased significantly beyond 5 mm distance, indicating a sharp drop in efficiency. Proper alignment between coils resulted in maximum brightness, while slight misalignment caused noticeable power loss. The solar tracking system showed improved output compared to a fixed panel, especially during changing sunlight conditions.

The solar tracking mechanism demonstrated improved energy generation compared to a stationary panel setup. The hybrid charging feature ensured continuous operation during low light conditions, enhancing system reliability. Overall, the results confirm that the proposed system effectively integrates solar energy with wireless power transfer for efficient operation.

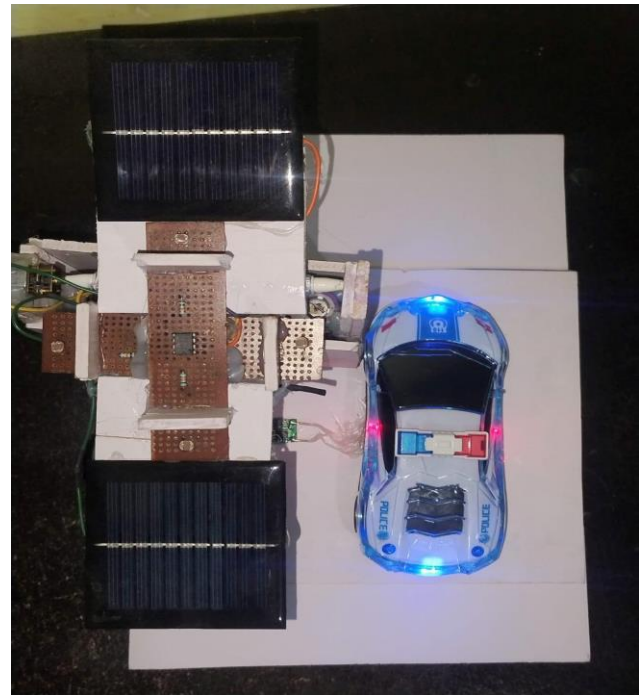

Fig-2 Hardware Prototype Model of the Proposed System

7. ADVANTAGES

The proposed system offers several advantages over conventional charging methods. It utilizes renewable solar energy, reducing dependency on non-renewable resources and minimizing environmental impact. The wireless charging feature eliminates the need for physical connectors, improving safety and convenience for users.

Additionally, the solar tracking mechanism increases energy generation efficiency, while the hybrid charging option ensures uninterrupted operation. The system is simple, cost effective, and suitable for small-scale implementation, making it a promising solution for future development.

8. LIMITATIONS

Despite its advantages, the system has certain limitations. The wireless power transfer efficiency is limited to short distances, and performance decreases with misalignment between the coils. This restricts its application to low power and close-range systems in its current form.

Furthermore, the output power of the solar panels is relatively low, which limits the charging capacity. Environmental factors such as weather conditions can also affect system performance. These limitations highlight the need for further improvements in design and efficiency.

9. FUTURE SCOPE

The proposed system can be further enhanced by increasing the power capacity and improving wireless transmission efficiency. Advanced coil designs and resonance techniques can be implemented to extend the range and efficiency of power transfer. Integration with smart control systems can also improve automation and performance monitoring.

In addition, the system can be scaled for real electric vehicle applications by using higher capacity batteries and larger solar arrays. The use of advanced tracking algorithms and energy management systems can further optimize performance. This opens opportunities for developing smart and sustainable charging infrastructure.

10. CONCLUSIONS

This paper presents a solar tracked wireless hybrid charging system that combines renewable energy with contactless power transfer technology. The system successfully demonstrates the integration of solar energy generation,

tracking mechanism, energy storage, and wireless transmission in a single platform. The results indicate that the system operates effectively under different conditions and provides a reliable charging solution.

The proposed model highlights the potential of using solar energy and wireless power transfer for future electric vehicle charging applications. Although currently limited to small-scale implementation, it provides a strong foundation for further research and development. With improvements in efficiency and scalability, this technology can play a significant role in the advancement of sustainable transportation systems.

The integration of renewable energy with wireless charging improves both efficiency and user convenience. The system provides a foundation for future advancements in smart and sustainable EV charging infrastructure.

REFERENCES

- [1] IEEE Papers on Wireless Power Transfer
- [2] Solar Tracking using LDR Sensors, IJERT
- [3] TP4056 Lithium-ion Charging Module Datasheet
- [4] XKT-412 Wireless Power Module
- [5] Renewable Energy Based EV Charging Systems