

A Low Power Consumption Scheme for Wireless Network

¹ D.P. Umbarkar , ²Mangesh Ukade , ³Suraj Varade , ⁴ Gayatri Sonawane

¹M-Tech (CSE), S.V.I.T, Chincholi , Nasik, Maharashtra – 422102.

^{2,3,4} B.E (CSE), S.V.I.T, Chincholi , Nasik, Maharashtra – 422102.

Abstract - In this paper we are going to develop a new energy effective communication technique for wireless sensor network it depends on the gray code technique. In this technique , binary formatted data is convert into Gray code format and then data is transmitted through CC2500 transmitter that use modulation schemes i.e. FSK and ASK so it keep the cost and complexity of the radio devices low. Our system simultaneously saves energy at both the end i.e .the transmitter and receiver. This energy effective communication technique used for various sectors such as remote healthcare , agriculture field monitoring ,industrial process monitoring environmental monitoring.

Key Words: Wireless Sensor network , Gray encoding , Silent Communication , Efficient communication.

1. INTRODUCTION

As we know that today's world surrounded by many wireless devices that form wireless networks, and communicate effectively to each other. Wireless network mainly consist of more number of sensor nodes. These nodes are self-organized with sensing data from various sectors [1] and collects information about the status of a different systems. Environment parameter such as temperature, vibration could be measured by using these sensors. Then the information is sent wirelessly and received by server or central nodes for further analysis and usage, collecting and sending such a large information through wirelessly a lot of energy is consume by these nodes and it is very challenging to charge or replace batteries of these nodes [2]. Thus energy effective communication is a very important part in WSN to reduce the device recharging cycle period and hence provide connectivity for longer duration. Wireless sensor networks are typically characterized by battery-powered sensor devices that are expected to operate over prolonged periods of time. But it is very difficult to replacing the batteries of these nodes quickly. So overcome this problems .We are going to develop a low power consumption scheme for these sensor nodes. In this scheme we convert binary code into gray code during

transmission of data. In this way Our System saves energy and extends battery life of these devices.

1.1 Existing System

Whenever Two devices starts communication with each other wirelessly then Wireless network is form between them , such a devices communicate a lot of information to each other .Whenever such a communication takes place the data is send in binary format. Most existing transmission schemes not only utilize non- zero voltage levels for both 0 and 1 so as to distinguish between a silent and a busy channel, they also keep both end i.e transmitter and receiver, switched on for the entire duration of the transmission of a data frame [3], so lot of energy consume by devices during transmission of data and makes a lot of impact on recharging cycle period of batteries, and battery life of devices get reduced .

1.2 Proposed System

We are going to develop a low power energy consumption technique that recodes a binary coded data using a redundant radix based number representation and convert into Gray code format. Actually our system is based on the binary to gray conversion, firstly in binary format whenever there is 1, the actual communication is done and energy is consumed, but when there is 0 in binary format, the energy is not required. Consider a simple example. i.e. 1111 in binary format as we know that 1 bit in binary number consume 4000 joule. Hence energy require for transmission is $4000 * 4 = 16000$ joule. But if you convert binary code format into gray code format then the above format become 1000. Hence $4000 * 1 = 4000$ joule of energy required. Hence the energy is save. Transmission save approximately 12000 joule of energy. This is our main purpose behind these paper.

Our main goal is to save energy at transmitter side and receiver side and to extends battery life of devices .

2. SYSTEM DESIGN

A new energy effective data communication method is design which is gray code method. In this techniques energy required for the data transmission is minimized as well as time required for data transmission is also less than the available systems.

2.1 Gray Code Technique

In gray code techniques data is transmitted using silent periods means energy is used only at the time of transmission of 1 and at the transmission of 0 energy is not used. In the previous system to transmit the data, it is transmitted in the form of binary number. But in the proposed system data is transmitted in the form of gray code because number of 1 obtain in the gray code is less than the number of 1 obtain in the binary code so energy used for the data transmission is less than the previous system. For example Binary number is 1110 then after converting this binary number into gray code 1001 number get. Number of 1 in binary number is 3 and number of 1 in gray code is 2, therefore energy consumed for binary code is greater than the gray code. At the receiving end also data is received in the form of gray code so at this end also energy is consumed.

2.2 Algorithm

- 1) In gray code the most significant bit is equal to the 1st bit of the given binary no.
- 2) Now the 2nd bit of the code is EX-or of the 1st and 2nd bit of the given binary no .i.e. if both the bits are identical then result obtain is 0 and if they are distinct the result is 1.
- 3) The 3rd bit of gray code is exclusively equal of the 2nd and 3rd bit of the given binary no. In this way the binary to the gray code conversion is takes place.

3. SYSTEM ARCHITECTURE

- 1) To create WSN it need to configure some sensor (e .g. Temp sensor) can be used to collect data from as like many sensors can be used. Data obtain is converted into digital signal by 10 bit internal ADC which generate decimal output up to 1024 decimal value. As it collects data from surrounding it is also called as sensor node.
- 2) Decimal number is directly given to a conversion central (PC or server) where an algorithm or function will convert decimal number into binary signal. i.e. either using any of the three techniques. The decimal (base ten) number system has 10 possible values (0, 1, 2, 3, 4, 5, 6, 7, 8 or 9) for each place value. In contrast, the binary number system has two possible value represented as 0 or 1 for each place value.

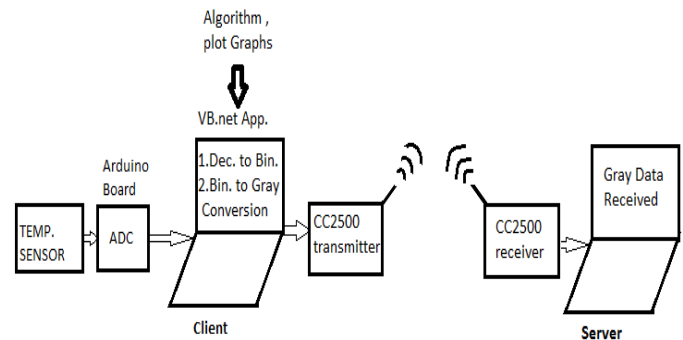

Fig.1. Our Proposed System

Since the binary system is the internal language of electronic computer, serious computer programs should understand how to convert from decimal to binary. Following are the simple steps how to convert these numbers.

- a) Short division by two with remainder.
- b) Write the integer answer (quotient) under the long division symbol, and write the remainder (0 or 1) to the right of the dividend.
- c) Continue the divided until you reach 0.
- 3) Once the number is obtain then that no is needed to be convert into gray as per our energy save technique for data transmission. For to convert it into gray it need to compare each MSB with nearest binary bit of data using X-OR logic. Then fill that data to an array and then once it get a final number to store the string.
- 4) Stored number is then given to transmitter node connected immediately to server using a microcontroller and CC2500 transceiver via a USB port to start serial communication.
- 5) CC2500 will receive the data obtained and then it shall be converted into a string, thus generate a complete sensor node.
- 6) Again at receiver side data is converted from gray to binary using a C++ function and a direct decimal value is obtained.
- 7) Decimal value obtained is display as temperature output on either on a LED or a computer

4. SYSTEM REQUIREMENT SPECIFICATION

4.1 Software Requirements

- a] Visual Studio 2005/8/10
- b] .net Frame Work 2.0 and above
- c] OS Xp Service pack 2 and above

4.2 Hardware Requirements

- a] 512 MB RAM
- b] 40 GB HDD
- c] Pentium processor with 1GHz processing Speed
- d] RF transmitter
- e] Microcontroller ARDINO board

5. ADVANTAGES

- 1) Reduce The Device Recharging Cycle Period.
- 2) Reduce RF Radiation.
- 3) Provide Connectivity For Longer Duration.
- 4) Our Proposed Implementation Can Extend The Battery Life Of Devices From About 33% To 62%.

6. APPLICATIONS

- 1) Remote Healthcare
- 2) Wireless Sensor Network for Agricultures
- 3) Industrial Process Monitoring
- 4) Environmental Monitoring
- 5) Target Tracking

7. CONCLUSIONS

In this paper we presents a new energy efficient communication technique that can reduce energy consumption at both the transmitter and receiver. Gray code method based on encoding the source data in gray code number system, coupled with the use of silent periods for communicating the 0's in the encoded message and transmission is done in gray code format. Reduce the Device Recharging Cycle Period and Our Proposed Implementation Can Extend the Battery Life Of devices from about 33% to 62%.

REFERENCES

- [1] Ian F. Akyildiz, Weilian Su, Yogesh Sankarasubramaniam, and Erdal Cayirci, "A Survey on Sensor Networks," in IEEE Communication Magazine, August 2002.
- [2] Ilker Demirkol, Cem Ersoy, and Fatih Alagoz, "MAC Protocols for Wireless Sensor Networks: A Survey," in IEEE Communication Magazine, April 2006.
- [3] Koushik Sinha, "An Energy-Efficient Communication Scheme for Wireless Networks:A Redundant Radix-Based Approach," IEEE Wireless Communication, vol. 10, no. 2, February 2011.
- [4] I. Demirkol, C. Ersoy, and F. Alagoz, "MAC Protocols for Wireless Sensor Networks, a Survey," IEEE Comm. Mag., 2005.
- [5] W. B. Heinzelman, A. Chandrakasan and H. Balakrishnan, "Energy efficient communication protocol for wireless microsensor networks," Proc. Intl. Conf. on Sys. Sc., 2000.
- [6] W. Ye, J. Heidemann and D. Estrin, "An energy-efficient MAC Protocol for Wireless Sensor Networks," Proc. IEEE Infocom, pp. 1567-1576, 2002.