

Performance Analysis of Shunt Active Power Filter In Unbalanced and Distorted Load

V.D.Pote¹, A.S.Bhagat², P.H.Jagtap³

^{1,2,3}Students, Dept. Of Electrical Engineering, SBPCOE Indapur, Maharashtra, India

Abstract - Due to wide use of the electronic equipments in the electrical system, like furnaces, adjustable speed drive and computer power supplies etc. Harmonics are present at the lines. Most of the pollution issues created in power systems are due to the non-linear characteristics and fast switching of power electronic equipment. Power quality issue is the main concern in the world now because it affects the production factories and industries. The power quality assumed to be high when it has constant voltage level and low voltage harmonic distortion and low number of disturbing transients.

Key Words: Filters, Transients, Harmonics, Distortions, SAPF, Compensation

1. INTRODUCTION

Harmonic current pollution of three-phase electrical power systems is becoming a serious problem due to the wide use of nonlinear loads, such as diode or thyristor rectifiers and a vast variety of power electronics based appliances. Traditionally, passive LC filters have been used to eliminate the current harmonics and to improve the power factor. However, passive LC filters are bulky, load dependent and inflexible. They can also cause resonance problems to the system. In order to solve these problems, APFs have been reported and considered as a possible solution for reducing current harmonics and improving the power factor. The basic compensation principle of the three phase shunt APF. It is designed to be connected in parallel with the nonlinear load to detect its harmonic and reactive current and to inject into the system a compensating current. In the conventional p-q Theory based control approach for the shunt APF; the compensation current references are generated based on the measurement of load currents. However, the current feedback from The SAPF output is also required and therefore, minimum six CSs are desired in an unbalanced system.

1.1 Power Quality Issues

As always, the main objective of the power system would be generation of electrical energy to the end user. Also, associated with power system generation is the term power quality. So much emphasis has been given to power quality that it is considered as a separate area of power engineering. There are many reasons for the importance given to the power quality. One of the main reasons is, the consumers are well informed about the power quality issues like interruptions, sagging and switching transients. Also, many power systems are internally connected into a network. Due to this integration if a failure exists in any one of the internal network it would result into unfavorable consequences to the whole power system. In addition to all this, with the microprocessor based controls, protective devices become more sensitive towards power quality variation than were the past generation protective devices.

2. Variations in Voltages

There are two types of voltage variations in the voltages:

A) Short Duration Voltage Variation

Short duration voltage variations are usually caused by faults in the power system. A short duration voltage variation consists of sags which are caused depending on the system conditions and faults that are caused in the power system. It really depends on What kind of fault is caused in the power system under what condition which may lead to voltage drops, voltage rise and even interruptions in certain conditions. When such fault takes place, protective devices are used in order to clear the fault. But, the impact of voltage during such faulty conditions is of short-duration variation.

B) Long Duration Voltage Variations

Long duration voltage variations are comprised of over voltages as well as under voltages conditions. These under voltage and over voltage conditions are caused by variations in the power system and not necessarily due to the faults in the system. The long duration voltage variations refer to the steady state condition of the RMS voltage of the power system. The long duration voltage Variations are further divided into three different categories i.e. interruptions, over voltage and under voltage.

3. Shunt Active Power Filter

Shunt active filters are by far the most widely accept and dominant flitters of choice in most industrial processes. Figure show the system configuration of the shunt design. The active filter is connected in parallel at the PCC and is fed from the main power circuit. The objective of the shunt active flitters is to supply opposing harmonic current to the nonlinear load effectively resulting in a net harmonic current. This means that the supply signals remain purely fundamental. Shunt filters also have the additional between of contributing to reactive power compensation and balancing of three-phase currents. Since the active filter is connected in parallel to the PCC, only the compensation current plus a small amount of active fundamental current is carried in the unit. For an increased range of power ratings, several shunt active filters can be combined together to withstand higher currents.

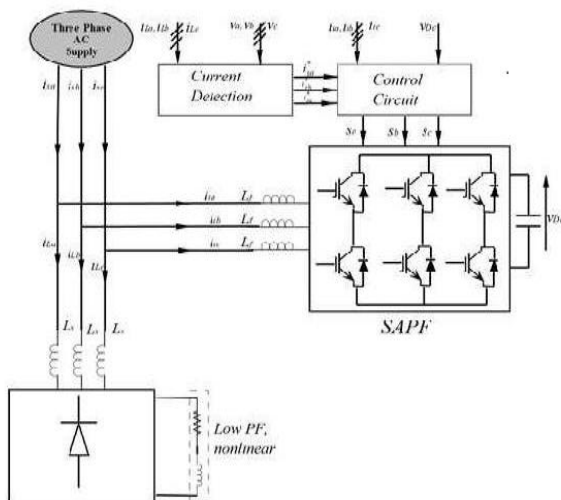

Fig -1: Shunt Active Power Filter

4. Synchronous Reference Frame Theory

This theorem relies on the Parks transformation to transform the three phase system voltage and current variables into synchronous rotating frame. The active and reactive components of the three phase system are the direct and represented by the direct and quadrature components respectively. Also fundamental components are transformed into DC quantities which can be separated easily through filtering. This theorem is applicable only to three phase system. Synchronous Reference Frame method is one of the most common and probably it is the best method. The method relies on the performance of the Proportional-Integral controller for obtaining the best control performance of the SAPF. To improve the performance of the PI controller, the feedback path to the integral term is introduced to compensate the winding up phenomenon due to integrator. Using Reference Frame Transformation, reference signals are transformed from a b c stationery frame to O d q rotating frame. Using the PI controller, the reference signals in the O d q rotating frame are controlled to get the desired reference signals for the Pulse Width Modulation. The synchronizer, the Phase Locked Loop with PI filter is used for synchronization, with much emphasis on minimizing delays. The system performance is examined with Shunt Active Power Filter simulation model.

5. Experimental Results

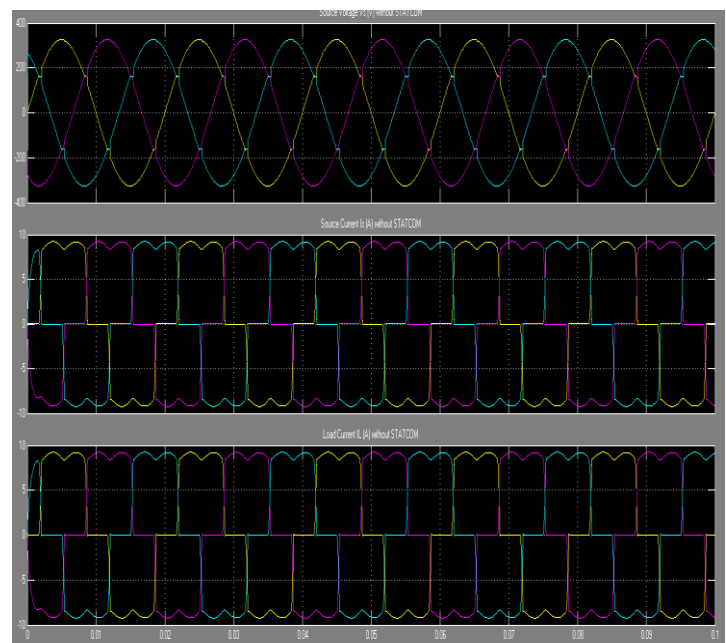

Fig-2: Output results

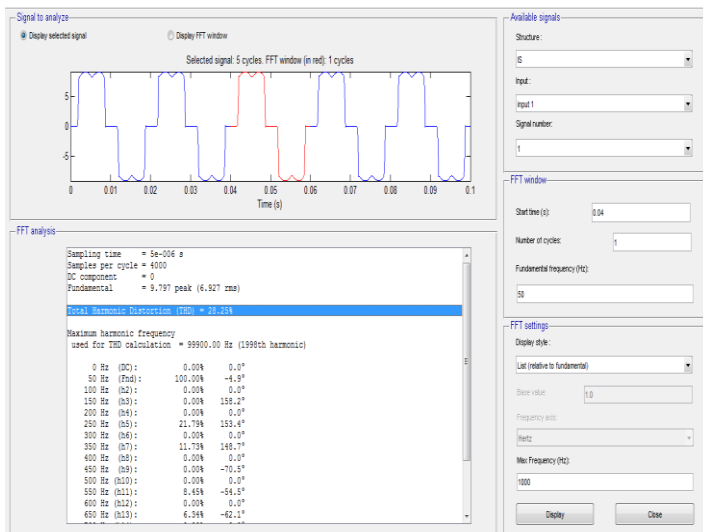

Fig-3 Total Harmonic Distortion

6. References

[1] Bhim Singh and JitendraSolanki, A Comparison of Control Algorithms for DSTATCOM IEEE transactions on Industrial electronics, vol. 56, no. 7, July 2009.

[2] Bollen, M.H. (1999), Understanding Power Quality Problems: Voltage Sags and Interruption. Wiley-IEEE Press, New Jersey.

[3] G. Bhuvaneswari, Manjula G. Nair, Design, Simulation, and Analog Circuit Implementation of a Three-Phase Shunt Active Filter Using the I cos Algorithm, IEEE transactions on power delivery, vol. 23, no. 2, April 2008.

[4] Misha Kumar, Control Implementations for High Bandwidth Shunt Active Filter A thesis, North Carolina State University.

[5] XiaoyanXu, Min He and Huayaozheng, Study of Electrical Power Improvement in Ship Network.IEEE 0-7803-9514 2006.