

WIRELESS CHARGING USING RF ENERGY

P.Surendar¹, S.Pramodh², M.Raj Kannan³

¹²³Student, Electronic and Telecommunication Engineering, Bharath University, Tamil Nadu, India

Abstract - Radio Frequency (RF) energy harvesting is an idea whose time has come. RF energy is everywhere. We are presenting a prototype for wireless charging system for mobile. This wireless battery charger is expected to eliminate all the hassles with today's battery technology. It would be convenient not having to worry about charging or changing the batteries and still have a working device. The advantage of this device is that it can wirelessly charge up the batteries which can save time and money in a long run for the general public.

Key Words - mobile phone, wireless battery charger, RF energy, RF Harvesting, batteries.

1. INTRODUCTION

We are being surrounded with Radio Frequency energy which is emitted by sources that generate high electromagnetic fields such as TV signals, wireless radio networks and cell phone towers. Today there are over billion cell phones, thousands radio stations and TV stations, and countless home Wi-Fi system radiating RF energy into the atmosphere.

Using the available Radio Frequency waves we are going to charge up the cell phone batteries without any external power source but with RF energy. The Fig 1 Block diagram shows how we have implemented the battery management and wireless charging circuit process.

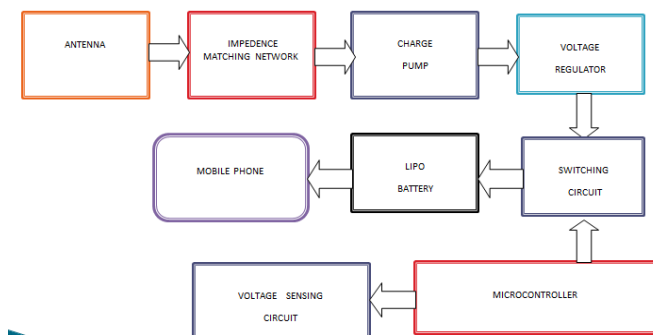

Fig 1 Block diagram of Wireless mobile charger

2. DESCRIPTION

2.1. DICKSON CHARGE PUMP

Charge pumps are the circuit that generates a voltage larger than the supply voltage from which they operate. To see how this is possible, consider the simple circuit consisting of a single capacitor and three switches in Fig 2.

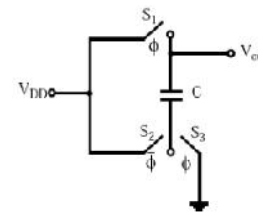

Fig 2 Simple Voltage Multiplier

During clock phase Φ , switches S1 and S3 are closed and capacitor is charged to a supply voltage, VDD. Next switch S2 is closed and the bottom plate of the capacitor assumes a potential VDD, while capacitor maintains its charge of $VDD \cdot C$ from the previous phase. This means that during phase Φ

$$(V_{out}-VDD).C = VDD.C \quad V_{out} = 2.VDD$$

Thus in the absence of dc load, an output voltage has been generated that is twice the supply voltage.

2.2. VOLAGE REGULATOR

The MC34063 is a monolithic switching regulator subsystem intended for use as dc-dc converters. This device represents a significant advancement in the ease of implementing highly efficient and yet simple switching power supplies. The use of switching regulators is becoming more pronounced over that of linear regulators because of size reduction in new equipment design require greater conversion efficiency. Another major advantage is that it has increased application flexibility of output voltage.

The output can be less than, greater than, or of opposite polarity to that of the input voltage.

2.3. ATMEL MICROCONTROLLER

The AT89S51 is a low-power, high-performance CMOS 8-bit microcontroller with 4K bytes of In-System Programmable Flash memory. The device is manufactured using Atmel's high-density nonvolatile memory technology and is compatible with the industry-standard 80C51 instruction set and pin out. The on-chip Flash allows the program memory to be reprogrammed in-system or by a conventional nonvolatile memory programmer.

By combining a versatile 8-bit CPU with In-System Programmable Flash on a monolithic chip, the Atmel AT89S51 is a powerful microcontroller which provides a highly-flexible and cost-effective solution to many embedded control applications.

2.4. ADC

The ADC0804 is CMOS 8-bit successive approximation A/D converter that uses a differential potentiometric ladder—similar to the 256R products. These converters are designed to allow operation with the NSC800 and INS8080A derivative control bus with TRI-STATE output latches directly driving the data bus. These A/Ds appear like memory locations or I/O ports to the microprocessor and no interfacing logic is needed.

Differential analog voltage inputs allow increasing the common-mode rejection and offsetting the analog zero input voltage value. In addition, the voltage reference input can be adjusted to allow encoding any smaller analog voltage span to the full 8 bits of resolution.

2.5. BATTERY

Batteries are classified into two broad categories, each type with advantages and disadvantages. Primary batteries irreversible (within limits of practically) transform chemical energy to electrical energy. When the initial supply of reactants is exhausted, energy cannot be readily restored to the battery by electrical means.

Secondary batteries can be recharged: they can have their chemical reactions reversed by supplying electrical energy to the cell, restoring their original composition. Some types of primary batteries used for example for telegraph circuits, were restored to operation by replacing the components of the battery consumed by the chemical reaction.

Secondary batteries are not indefinitely rechargeable due to dissipation of the active materials, loss of electrolyte and internal corrosion.

2.6. SCHOTTKY BARRIER RECTIFIERS

This series employs the Schottky Barrier principle in a large area metal-to-silicon power diode. State-of-the-art geometry features chrome barrier metal, epitaxial construction with oxide passivation and metal overlap contact. Ideally suited for use as rectifiers in low-voltage, high-frequency inverters, freewheeling diodes, and polarity protection diodes.

2.7. VOLTAGE SENSING CIRCUIT

A voltage sensor circuit is a circuit that can sense the voltage input into it. If the voltage reaches a certain threshold, then an indicator, such as an LED, will turn on. This is a voltage sensor circuit, where if in voltage reaches threshold point, then the output will turn on. And we can build a voltage sensor circuit, simply with a voltage comparator chip or an op amp that can function as a voltage comparator. A voltage comparator chip is a chip that contains one or more op amps. Using a single op-amp, we can determine a threshold level for voltage. An op-amp has two inputs and one output. The two inputs are the non-inverting input and the inverting input. Into the inverting input, we place the reference voltage or the threshold voltage. If the voltage at the non-inverting terminal reaches or goes above this level, the output will turn on.

Therefore, once we feed a certain level of voltage into the inverting terminal, if the voltage at the non-inverting terminal goes above, an output, such as an LED, will light up. This is how we can know that the voltage is above the threshold point.

3. ADVANTAGES

- Utilizing energy (RF) that is free of cost and abundant in nature.
- RF energy is available 24*7, unlike solar energy that is available only during day light and dependent much on cloud and shade.
- Use of separate chargers is eliminated.
- Electricity is saved.
- The phone can be charged anywhere anytime.
- Lower risk of electrical shock because there are no exposed conductors.

4. CONCLUSION

Accordingly this paper effectively shows the idea of charging the mobile phones in on the go manner without the use of wired chargers. This idea of wireless charging will create a great comfort for the mobile telephone users as it does not require special external power source other than the radio frequency waves which is available in the atmosphere in abundant.

The future scope of this paper is that whole idea can be implemented inside mobile phones by designing all required circuit inside a single IC.

5. REFERENCES

- [1] Roundy, S. J., "Energy scavenging for wireless sensor nodes with a focus on vibration to electricity conversion," PhD Thesis, University of California, Berkeley, USA, 2003.
- [2] Hart, H., K. Lanham, and M. Sass, "S-band radio frequency energy harvesting," Science Applications International Corporation, May 2009.
- [3] Arrawatia, M., M. S. Baghini, and G. Kumar, "RF energy Progress in Electromagnetics Research, Vol. 132, 2012 69 harvesting system from cell towers in 900 MHz band," National Conference on Communications, (NCC) 2011, 1-5, Jan. 28-30, 2011.
- [4] Jabbar, H., Y. S. Song, and T. T. Jeong, "RF energy harvesting system and circuits for charging of mobile devices consumer electrons," IEEE Transactions on Consumer Electronics, Vol. 56, No. 1, 247-253, Feb. 2010.
- [5] Devi, K.K. A., S. Sadasivam, N. M. Din, C. K. Chakraborty, and S. K. Rajib, "Design of a wideband 377 Ω E-shaped patch antenna for RF energy harvesting," Microwave and Optical Technology Letters, Vol. 54, No. 3, 569-573, Mar. 2012.
- [6] Harris, D. W., "Wireless battery charging system using radio frequency energy harvesting," Thesis, BS, University of Pittsburgh, Jul. 13-15, 2004.
- [7] Ugan, T. and L. M. Reindl, "Concept for harvesting low ambient RF-sources for microsystems", Accessed on April 9, 2009.