

Equalization Techniques for MIMO Systems in Wireless Communication: A Review

Chandani Dewangan¹ Manoj Gulhane²

¹Research Scholar, Electronics & Telecommunication Department, DIMAT, Raipur (C.G.)

²Asst. Prof., Electronics & Telecommunication Department, DIMAT, Raipur (C.G.)

¹ziakhan5570@yahoo.com

Abstract-The main objective of this paper is to provide a review of equalization techniques in multiple input, multiple output (MIMO) communication system. In wireless communication inter symbol interference is major obstacle which greatly affect the data quality. The chief goal of equalization techniques is to rebuild the actual signal with the help of filter or any other methods and remove the effect of ISI so that the reliability of data transmission is maintained. Different kind of equalization techniques proposed earlier has been reviewed here.

Keywords- MIMO, interference, MMSE, Adaptive, filter

1. INTRODUCTION

Main aim of wireless technology is to offer better quality voice, data, pictures, fax, and video. Terrestrial digital T.V. broadcasting, LTE, 3GPP are some of the latest advancement in the field of wireless communication. These above mentioned advancement are possible with the help of OFDM and CDMA technology. In a last few years OFDM has emerged as a most popular technique of transmitting data/signal over

wireless media. In OFDM, signal are transmitted in sub-channel of different frequency in parallel fashion. The frequency of sub-channel are so selected that these frequency are orthogonal to each other and therefore do not interfere with each other. This phenomenon makes it possible to transmit the data in overlapping frequency and hence reduced the bandwidth requirement considerably[1].

Since in wireless communication data are sent in radio space, the channel exhibits multipath fading phenomenon which produces inter-symbol interference (ISI) in the signal received at the receiver side.

Inter-symbol interference (ISI) is undesirable and it increases the bit error rate.

Whenever the modulation bandwidth exceeds the radio channel coherence bandwidth, ISI produced. In order to reduce or eliminate inter-symbol interference (ISI), different types of equalization techniques are used which

compensate the ISI using impulse response of channel [2].

Equalizer work by keeping bit error rate as low as possible and SNR as high as possible[3].

These equalization techniques proved to be very important for designing wireless system with high data rate transmission capacity. Most of the wireless receiver are equipped with the equalizer which gives good result under expected

In wireless communication, the receivers are generally equipped with the equalizer which gives average performance.

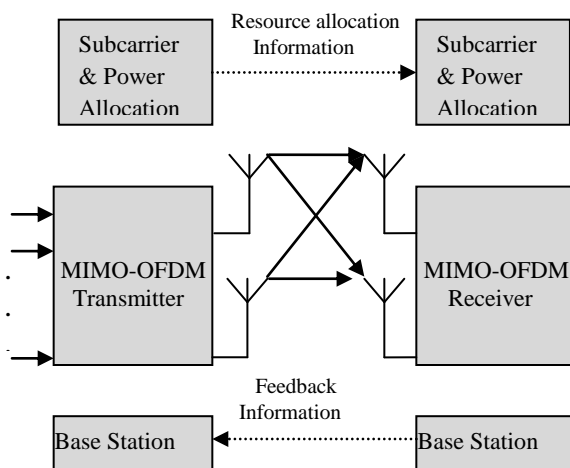

Figure 1.1 MIMO Communication system

The quality of wireless communication depends upon the three parameters i.e. rate, range and reliability of transmission. These parameter are related with each other. The rate of transmission can be improved by reducing the range and

reliability of transmission. Similarly, the range of transmission can be extended by reducing the rate of transmission and reliability.

Simultaneously improvement in all the three parameters can be accomplished with the help of new technique called MIMO assisted OFDM. Because of the capability of offering increased link range and data throughput without the requirement of extra bandwidth and transmit power, MIMO has become a main theme for the researchers in the field of communication[4]. MIMO gives higher link reliability and spectral efficiency. The combination of MIMO Communication system and Orthogonal frequency division multiplexing (OFDM) modulation technique is capable of achieving high data rate transmission reliably in broad band wireless channel[5].

In any wireless system, in order to exploit the property of frequency selectivity of wireless channel, there is a need to design an efficient, practical and low complexity equalization technique for designing high data rate wireless system[6]. Different types of adaptive equalizer has been proposed in past which can be used to fight inter-symbol interference while maintaining the diversity[7]. In this paper an effort has been made to go through the

background and past work done in the field of equalization process.

2. BACKGROUND

The wireless communication concept came into existence when In 1928 Nyquist laid down the theory of telegraph transmission [8] which also became the foundation of pulse transmission.

Widrow and Hoff [9] proposed least mean square based adaptive filter algorithm in 1960 which was the foundation of adaptive equalization method . Most of the research on adaptive equalization in early 60's were concentrated on the basic fundamental and structure of zero forcing transversal equalizer[10]. Meanwhile in parallel some work has been done in the same period for developing the theory and structure of linear transmit and receive filters[11][12] which can minimize the mean square error for additive Gaussian noise channels[13].

In early 70's Transversal and decision-feedback equalizing process with forward filter tap spacing which is less than the interval of symbol has been proposed[14]. These equalizers were later on used in commercial telephone line modem[15][16] and in military radio system[17]. Until the early part of 70's most of the work related with equalization were centered to the structure and steady state analysis. After that most of the work were centered on developing some computationally efficient algorithm of equalization.RLS algorithm was one of the computationally efficient method of equalization

which became the intense research subject[18][19][20][21][22] in the field of equalization at that time which eventually led to the transversal [23][24][25] and lattice[26][27][28][29][30][31] algorithm. Later these method were applied to adaptive equalizer for HF modem[32].An equalization operation is generally performed at baseband or IF in a receiver section.

A lot of work has been proposed in the past for combating and reducing inter symbol interference in MIMO communication system.Equalization is one of them. Equalization techniques is divided into three part. The first one frequency domain equalization techniques which includes pre-tone equalization and it is used where channel order is larger than the cyclic prefix. The second one is time domain equalization techniques which includes channel shortening and time domain statistics-based techniques. The third one is turbo equalization which is iterative based equalization technique. Some of the noteworthy algorithm of equalization is presented in the next sections of this paper.

3. Adaptive Equalizer [33]

Randomness and time varying property of fading channel makes it necessary to design

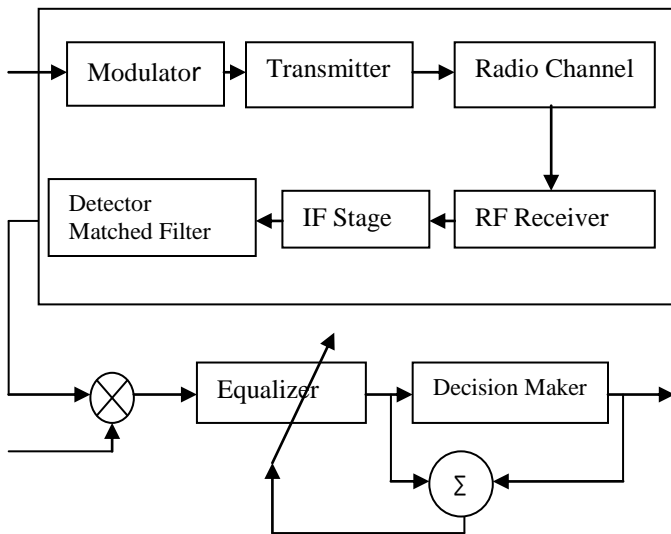

Figure 1.2 Adaptive Equalizer

a equalizer which is capable of tracking the time varying property of mobile channel and hence known as adaptive equalizers.

Block diagram of adaptive equalization process[33] is shown in Figure 1.2.

If $s(t)$ is the original signal and $f(t)$ represent the collective complex base-band impulse response of channel, Transmitter and IF/RF section of receiver, then the signal received at the input of equalizer is given by

$$x(t) = s(t) \otimes f^*(t) + n_b(t)$$

Here $f^*(t)$ is complex conjugate of $f(t)$ and $n_b(t)$ is noise of baseband while symbol \otimes

Represent the convolution operation. The output of an equalizer can be represented by

$$y(t) = x(t) \otimes h_{eq}(t)$$

or it can be written as

$$y(t) = s(t) \otimes f^*(t) \otimes h_{eq}(t) + n_b(t) \otimes h_{eq}(t)$$

where $h_{eq}(t)$ represent the equalizer impulse response. If the combined response of transmitter, communication channel and IF/RF section of receiver is represented by $g(t)$ then the above equation can also be written as

$$y(t) = h(t) \otimes g(t) + n_b(t) \otimes h_{eq}(t)$$

Impulse response of the equalizers transversal filter can be expressed as

$$h_{eq}(t) = \sum_n c_n \delta(t - nT)$$

Here C_n represent the complex coefficients of filter at the equalizer.

Since the desired output signal of the equalizer is nothing but the original signal $s(t)$. Therefore in order to make $y(t) = s(t)$ in equation

$$y(t) = s(t) \otimes f^*(t) \otimes h_{eq}(t) + n_b(t) \otimes h_{eq}(t)$$

the value of $g(t)$ must be

$$g(t) = f^*(t) \otimes h_{eq}(t) = \delta(t)$$

the main aim of equalizer is to fulfill the following equation

$$H_{eq}(f) F^*(-f)=1$$

Where $H_{eq}(f)$ represents fourier transform of $h_{eq}(t)$ and $F(f)$ represent Fourier transforms of $f(t)$.

4. Zero forcing Equalizer[34]

In this method [34], the ISI component at the output of equalizer is forced to zero by using appropriate linear time invariant filter having suitable transfer function.

If transmitted symbol is represented by x_1 and x_2 , h_{11} represent the channel from first transmitter to first receiver, h_{12} represent the channel from second transmitter to first receiver, h_{21} represent the channel from first transmitter to second receiver and h_{22} represent the channel from second transmitter to second receiver and n_1, n_2 represent noise on first and second receiver then the received symbol on first receiver is given by

$$y_1 = h_{11}x_1 + h_{12}x_2 + n_1$$

$$= [h_{11} \ h_{12}] \begin{bmatrix} x_1 \\ x_2 \end{bmatrix} + n_1$$

And the received symbol on second receiver is given by

$$y_2 = h_{21}x_1 + h_{22}x_2 + n_2$$

$$= [h_{21} \ h_{22}] \begin{bmatrix} x_1 \\ x_2 \end{bmatrix} + n_2$$

These two above equation can also be written as

$$\begin{bmatrix} y_1 \\ y_2 \end{bmatrix} = \begin{bmatrix} h_{11} & h_{12} \\ h_{21} & h_{22} \end{bmatrix} \begin{bmatrix} x_1 \\ x_2 \end{bmatrix} + \begin{bmatrix} n_1 \\ n_2 \end{bmatrix}$$

It is clear from this equation that if $h_{11}, h_{12}, h_{21}, h_{22}$ and y_1, y_2 is known then it is easier for the receiver to compute the x_1 and x_2 .

Now if we rewrite the above equation then

$$y = Hx + n$$

From here it is clear that in order to find x from above equation, we need to find out the matrix which is inverse of matrix H . If W represent the inverse of H then it must satisfy the property

$$WH = I$$

Where I is the identity matrix.

The matrix W which satisfy the above mentioned property is known as the zero forcing linear detector and is computed by following equation

$$W = (H^H H)^{-1} H^H$$

In this equation the matrix $H^H H$ is given by

$$H^H H = \begin{bmatrix} h_{11}^* & h_{12}^* \\ h_{21}^* & h_{22}^* \end{bmatrix} \begin{bmatrix} h_{11} & h_{12} \\ h_{21} & h_{22} \end{bmatrix}$$

From this matrix it is clear that the off diagonal term are non zero and hence zero forcing equalizer cancel out the interference signal. It is reasonably simple and easy to implement but its main drawback is that it tends to amplify the noise and hence gives noisy output.

5. MMSE Equalizer (Minimum Mean Squared Error)

This type of equalizer uses the squared error as performance measurement[35]. The receiver filter is designed to fulfill the minimum mean square error criterion. Main objective of this method is to minimize the error between target signal and output obtained by filter. The computation for this method is as follows-

If transmitted symbol is represented by x_1 and x_2 , h_{11} represent the channel from first transmitter to first receiver, h_{12} represent the channel from second transmitter to first receiver, h_{21} represent the channel from first transmitter to second receiver and h_{22} represent the channel from second transmitter to second receiver and n_1, n_2 represent noise on first and second receiver then the received symbol on first receiver is given by

$$\begin{aligned} y_1 &= h_{11}x_1 + h_{12}x_2 + n_1 \\ &= [h_{11} \ h_{12}] \begin{bmatrix} x_1 \\ x_2 \end{bmatrix} + n_1 \end{aligned}$$

And the received symbol on second receiver is given by

$$\begin{aligned} y_2 &= h_{21}x_1 + h_{22}x_2 + n_2 \\ &= [h_{21} \ h_{22}] \begin{bmatrix} x_1 \\ x_2 \end{bmatrix} + n_2 \end{aligned}$$

These two above equation can also be written as

$$\begin{bmatrix} y_1 \\ y_2 \end{bmatrix} = \begin{bmatrix} h_{11} & h_{12} \\ h_{21} & h_{22} \end{bmatrix} \begin{bmatrix} x_1 \\ x_2 \end{bmatrix} + \begin{bmatrix} n_1 \\ n_2 \end{bmatrix}$$

It is clear from this equation that if $h_{11}, h_{12}, h_{21}, h_{22}$ and y_1, y_2 is known then it is easier for the receiver to compute the x_1 and x_2 .

Now if we rewrite the above equation then

$$y = Hx + n$$

Now, MMSE algorithm computes the coefficient of matrix W which minimize the condition

$$E \{ [w_y - x][w_y - x]^H \}$$

Solving above equation gives

$$W = (H^H H + N_o I)^{-1} H^H$$

From the above equation it is clear that this equation is different from the equation of zero forcing equalizer by the term $N_o I$. If we put $N_o I = 0$ in this equation then MMSE equalizer becomes zero forcing equalizer.

6. Zero Forcing with Successive Interference Cancellation (ZF-SIC)

In this method, first of all the zero forcing equalizer find the estimated symbol x_1 and x_2 then one of the estimated symbol is subtracted from received symbol to compute the equalized symbol by applying maximum ratio combining(MRC)[36].

If x_1 and x_2 are the estimated transmitted symbol then

$$\begin{bmatrix} \hat{x}_1 \\ \hat{x}_2 \end{bmatrix} = (H^H H)^{-1} H^H \begin{bmatrix} y_1 \\ y_2 \end{bmatrix}$$

By subtracting one of the estimated symbol (say \hat{x}_2) from the received signal y_1 and y_2

$$\begin{bmatrix} r_1 \\ r_2 \end{bmatrix} = \begin{bmatrix} y_1 - h_{12} \hat{x}_2 \\ y_2 - h_{22} \hat{x}_2 \end{bmatrix} = \begin{bmatrix} h_{11} x_1 + n_1 \\ h_{21} x_1 + n_2 \end{bmatrix}$$

$$\begin{bmatrix} r_1 \\ r_2 \end{bmatrix} = \begin{bmatrix} h_{11} \\ h_{21} \end{bmatrix} x_1 + \begin{bmatrix} n_1 \\ n_2 \end{bmatrix}$$

Or

$$r = hx_1 + n$$

By applying maximum ratio combining(MRC), the equalized symbol is given by

$$\hat{x}_1 = \frac{h^H r}{h^H h}$$

7. Successive Interference Cancellation using optimal ordering[37]

In the previous successive interference cancellation method, estimation symbol is chosen arbitrarily and then its effect is

subtracted from received symbol y_1 and y_2 . A better result can be obtained if we choose estimated symbol whose influence is more than other symbol. For this first of all the power of both the symbol is computed at the receivers and then the symbol having higher power is chosen for subtraction process.

The power of transmitted symbol x_1 is given by

$$P_{x_1} = |h_{11}|^2 + |h_{21}|^2$$

Similarly the power of transmitted symbol x_2 is given by

$$P_{x_2} = |h_{12}|^2 + |h_{22}|^2$$

If $P_{x_1} > P_{x_2}$, the x_1 is subtracted from y_1 and y_2 and re-estimate the \hat{x}_2

i.e.

$$\begin{bmatrix} r_1 \\ r_2 \end{bmatrix} = \begin{bmatrix} y_1 - h_{11} \hat{x}_1 \\ y_2 - h_{12} \hat{x}_1 \end{bmatrix} = \begin{bmatrix} h_{12} \hat{x}_2 + n_1 \\ h_{22} \hat{x}_2 + n_2 \end{bmatrix}$$

$$\begin{bmatrix} r_1 \\ r_2 \end{bmatrix} = \begin{bmatrix} h_{12} \\ h_{22} \end{bmatrix} x_2 + \begin{bmatrix} n_1 \\ n_2 \end{bmatrix}$$

$$r = hx_2 + n$$

By applying maximum ratio combining (MRC), the equalized symbol is given by

$$\hat{x}_2 = \frac{h^H r}{h^H h}$$

Similarly if $P_{x_2} > P_{x_1}$, the x_2 is subtracted from y_1 and y_2 and re-estimate the \hat{x}_1 .

These are some of the most important equalization algorithm which are widely used in

MIMO communication system. It is very important to see how these methods perform under different noise and channel conditions.

Sahu[38] in his paper discussed the performance of MIMO system for Rayleigh channel. In his paper he discussed the MIMO system, its BER performance SNR and error performance for different equalizers. he also mentioned the correlation between elements of antenna. Maximal Ratio Combining (MRC) technique was used for analyzing receiver diversity. He also done the comparison for equal gain combining and selection combining. The equalization is done by maximum mean squared error(MMSE), ML(Maximum likelihood method) and ZF(zero forcing) method. For 10 Db SNR, BER for ZF equalizer is obtained as 10^{-4} while the BER obtained for MMSE equalizer is between 10^{-4} to 10^{-5} . Best performance is obtained using ML equalizer which gives the BER exactly 10^{-5} .

Kanchan[39] in his paper presented a detailed analysis of OFDM communication system for different fading environment. In his approach she applied zero forcing(ZF) and Minimum mean square Error (MMSE) for equalization purpose. She also applied multicarrier modulation for getting better reduction in inter-symbol interference (ISI) along with high reliability and

better performance over fading channel conditions.

In her paper she also pointed out that the performance of MMSE equalizer is better because it is not able to eliminate the ISI totally but also able to minimize the total noise power. She also showed that if number of receiving antenna is increased with respect to transmitting antenna then BER decreases in case of MMSE equalizer.

V.Jagan [40] in his paper proposed that limitation of dispersive fading can be eliminated and co channel interference can be reduced by combining OFDM and CDMA. In order to study the equalization techniques in reducing the ISI, he also applied different equalization techniques for flat fading Rayleigh multipath channel using BPSK modulation. He applied zero forcing (ZF), MMSE, Zero forcing equalization with successive interference cancellation(ZF-SIC), ZF-SIC for optimal ordering and MMSE-SIC. ZF-SIC shows an improvement of 2.2 dB over ZF in case of BER of 10^{-3} . while ZF-SIC for optimal ordering gives 2.0dB improvement over ZF-SIC in case of BER of 10^{-3} . MMSE-SIC with optimal ordering gives an improvement of 5.0 dB over MMSE-SIC for BER of 10^{-3} . So from this figure it is clear that MMSE-SIC with optimal ordering is best in ISI cancellation.

8. CONCLUSION

Multiple input Multiple output transmission techniques is a new concept of providing the high speed data transmission in wireless communication system. Inter symbol interference is one of the impediments for achieving reliable high speed data transmission over wireless media. In order to nullify the effect of Inter symbol interference (ISI) at the receiver side, equalization techniques or equalizer is used. The main function of the equalizer is to reconstruct the actual signal with the help of channel response and estimated signal or symbol.

This paper reviewed some of the basic approaches of equalization methods which can be used to nullify the inter symbol interference (ISI) effect and reconstruct the original signal.

References

- [1]. G.L. Stuber, J.R. Barry, S.W. McLaughlin, Ye Li, M.A. Ingram and T.G. Pratt, "Broadband MIMO-OFDM wireless communications," Proceedings of the IEEE, vol. 92, No. 2, pp. 271-294, February. 2004.
- [2]. [DIG-COMM-BARRY LEEMESSERSCHMITT], Digital Communication: Third Edition, by John R. Barry, Edward A. Lee, David G. Messerschmitt
- [3]. Shailesh Shankhi, K. Satya Prasad, "Performance Analysis of Channel Estimation Based on MMSE Equalizer in OFDM System", International Journal of Advanced Innovative Research, Vol. 2 Issue 8, ISSN: 2278-7844, pp. no.-155-159.
- [4]. Madan Lal, Hamneet Arora, "BER Performance of Different Modulation Schemes for MIMO Systems", International Journal of Computer Science and Network Security (IJCSNS), VOL.11 No.3, pp.no.-69-72. March 2011.
- [5]. Kala Praveen Bagadi, Prof. Susmita Das, MIMO OFDM Channel Estimation using Pilot Carriers, International Journal of Computer Applications, ISSN No.- 0975 - 8887, Volume 2 - No.3, pp 81-88, May 2010
- [6] [WIRELESS-TSE, VISWANATH] Fundamentals of Wireless Communication, David Tse, Pramod Viswanath.
- [7] G. Leus, S. Zhou, and G. B. Giannakis, "Orthogonal multiple access over time- and frequency-selective channels," IEEE Transactions on Information Theory, vol. 49, no. 8, pp. 1942-1950, 2003.
- [8] H. Nyquist, "Certain topics in telegraph transmission theory," *Trans. AIEE*, vol. 47, pp. 617-644, Apr. 1928.
- [9] B. Widrow and M. E. Hoff, Jr., "Adaptive switching circuits," in *REWESCON Conv. Rec.*, pt. 4, pp. 96-104, Aug. 1960.
- [10] "Techniques for adaptive equalization of digital communication systems," *Bell Syst. Tech. J.*, vol. 45, pp. 255-286, Feb. 1966.

- [11] J. W. Smith, "The joint optimization of transmitted signal and receiving filter for data transmission systems," *Bell Syst. Tech. J.*, vol. 44, pp. 2363-2392, Dec. 1965.
- [12] D. W. Tufts, "Nyquist's problem-The joint optimization of transmitter and receiver in pulse amplitude modulation," *Proc. IEEE*, vol. 53, pp. 248-260, Mar. 1965.
- [13] D. A. George, "Matched filters for interfering signals," *IEEE Trans. Inform. Theory* (Corresp.), vol. IT-11, pp. 153-154, Jan. 1965.
- [14] D. M. Brady, "An adaptive coherent diversity receiver for data transmission through dispersive media," in *Proc. 7970 IEEE Int. Conf. Commun.*, pp. 21-35 to 21-39, June 1970.
- [15] C. D. Forney, S. U. H. Qureshi, and C. K. Miller, "Multipoint networks: Advances in modem design and control," in *Nat. Telecom. Conf. Rec.*, pp. 50-1 -1 to 50-1 -4, Dec. 1976.
- [16] H. L. Logan and C. D. Forney, Jr., "A MOS/LSI multiple configuration 9600 b/s data modem," in *Proc. IEEE Int. Conf. Commun.*, pp. 48-7 to 48-12, June 1976.
- [17] P. Monsen, "Theoretical and measured performance of a DFE modem on a fading multipath channel," *IEEE Trans. Commun.*, vol. COM-25, pp. 1144-1153, Oct. 1977.
- [18] M. L. Honig and D. G. Messerschmitt, *Adaptive Filters; Structures, Algorithms, and Applications*. Boston, MA: Kluwer Academic Pub., 1984.
- [19] M. Morf, T. Kailath, and L. Ljung, "Fast algorithms for recursive identification," in *Proc. 7976 IEEE Conf. Decision Contr.* (Clearwater Beach, FL, Dec. 1976), pp. 916-921.
- [20] M. S. Mueller, "Least-squares algorithms for adaptive equalizers," *Bell Syst. Tech. J.*, vol. 60, pp. 1905-1925, Oct. 1981.
- [21] "On the rapid initial convergence of least-square equalizer adjustment algorithms," *Bell Syst. Tech. J.*, vol. 60, pp. 2345-2358, Dec. 1981.
- [22] K. Murano, Y. Mochida, F. Amano, and T. Kinoshita, "Multiprocessor architecture for voiceband data processing (application to 9600 bps modem)," in *Proc. IEEE Int. Conf. Commun.*, pp. 37.3.1-37.3.5, June 1979.
- [23] J. M. Cioffi and T. Kailath, "Fast, recursive-least-squares, transversal filters for adaptive filtering," *IEEE Trans. Acoust., Speech, Signal Process.*, vol. ASSP-32, pp. 304-337, Apr. 1984.
- [24] J. M. Cioffi and T. Kailath, "An efficient exact-least-squares fractionally spaced equalizer using intersymbol interpolation," *IEEE J. Selected Areas Commun.*, vol. SAC-2, pp. 743-756, Sept. 1984.
- [25] D. D. Falconer and L. Ljung, "Application of fast Kalman estimation to adaptive equalization," *IEEE Trans. Commun.*, VOIC. OM-26, pp. 1439-1446, Oct. 1978.
- [26] F. Ling and J. G. Proakis, "A generalized multichannel least squares lattice algorithm based on sequential processing stages," *IEEE Trans. Acoust., Speech, Signal Process.*, vol. ASSP-32, pp. 381-389, Apr. 1984.
- [27] J. Makhoul, "A class of all-zero lattice digital filters: properties and applications," *IEEE Trans. Acoust., Speech, Signal Process.*, vol. ASSP-26, pp. 304-314, Aug. 1978.
- [28] M. Morf, T. Kailath, and L. Ljung, "Fast algorithms for recursive identification," in *Proc. 7976 IEEE Conf. Decision Contr.* (Clearwater Beach, FL, Dec. 1976), pp. 916-921.
- [29] E. H. Satorius and S. T. Alexander, "Channel equalization using adaptive lattice algorithms," *IEEE Trans. Commun.* (Concise Paper), vol. COM-27, pp. 899-905, June 1979.
- [30] E. H. Satorius and J. D. Pack, "Application of least squares lattice algorithms to adaptive equalization," *IEEE Trans. Commun.*, vol. COM-29, pp. 136-142, Feb. 1981.
- [31] B. Friedlander, "Lattice filters for adaptive processing," *Proc. IEEE*, vol. 70, pp. 829-867, Aug. 1982.

- [32] *Digital Communications*. New York: McCraw-Hill, 1983.
- [33] "Adaptive Equalization" by SHAHID U. H. QURESHI, SENIOR MEMBER, IEEE
Vol.4, No.4, October, 2010
- [34] "ZERO-FORCING EQUALIZATION FOR TIME-VARYING SYSTEMS WITH MEMORY " by Cassio B. Ribeiro, Marcello L. R. de Campos, and Paulo S. R. Diniz.
- [35] ZERO-FORCING FREQUENCY DOMAIN EQUALIZATION FOR DMT SYSTEMS WITH INSUFFICIENT GUARD INTERVAL by Tanja Karp , Martin J. Wolf , Steffen Trautmann , and Norbert J. Fliege
- [36] *Wireless communications and networks : second edition*, by Theodore S. Rappaport
- [37] G. Leus, S. Zhou, and G. B. Giannakis, "Orthogonal multiple access over time- and frequency-selective channels," *IEEE Transactions on Information Theory*, vol. 49, no. 8, pp. 1942–1950, 2003.
- [38]. Amit Kumar Sahu, Sudhansu Sekhar Singh, "BER Performance Improvement Using MIMO Technique Over Rayleigh Wireless Channel With Different Equalizers", *International Journal of Engineering and Technology (IJET)*, ISSN No.-,333-340.
- [39]. Anuj Kanchan, Shashank Dwivedi, "Comparison of BER Performance in OFDM Using Different Equalization Techniques", *International Journal of Engineering and Advanced Technology(IJEAT)* ISSN: 2249 – 8958, Volume-1, Issue-6, August 2012, pp. no.- 139-143.
- [40]. V.Jagan Naveen, K.Murali Krishna, K.Raja Rajeswari, "Performance analysis of equalization techniques for MIMO systems in wireless communication", *International Journal of Smart Home* Vol.4, No.4, pp. no.-47-63, October 2010.