

Experimental Study of Heat Transfer Coefficient of Water In Horizontal Tube

Suraj V. Kadam¹, M.D. Hambarde²

¹Department of Mechanical Engineering, MIT Pune, Savitribai Phule Pune University, Maharashtra, India

²Department of Mechanical Engineering, MIT Pune, Savitribai Phule Pune University, Maharashtra, India

Abstract –An investigation is done for studying the effect of heat flux and mass flux on the variation of heat transfer coefficient for the water inside the tube. As many applications are involve the heat transfer coefficient inside the small diameter tube Like,heat exchangers, refrigerants boilers and some food industries are also require for food processing. The flow inside the plain tube is two phase flow, for this experimental setup is designed which include the copper tube with internal diameter of 8mm and outer diameter of 10mm, length of the test section is 1.5m, heat flux range is fixed in the range of 1 kW/m² to 9 kW/m² and mass flux range is fixed within the range of 50 kg/m²s to 220 kg/m²s.the system pressure is atmospheric hence water properties are considered according to the saturation temperature and pressure. This study will help to decrease the size and actual design with same efficiency with reduced material cost.

Key Words: two-phase, flow boiling, water, calculation, correlation.

1.INTRODUCTION

The interest in this experimentation is to decrease material and also operating cost. Variety of refrigerant which are present in the markets according to their application but cost of these refrigerants are comparatively much more than the water hence can't be used in the huge amount. Now a day's conventional ways are preferred more because they are more efficient and safe for both to humans and nature too. For using water as a refrigerant properties of water are need to be reconsidered at the two phase condition.

Designing of the condenser or the evaporator is require actual heat transfer rate which will help to reduce the size of the equipment otherwise problem of over-design or under-design of evaporator, condenser or such type of two phase process equipment may occurs. The correct prediction of the heat transfer coefficient in two phase flow is being considered as very important, as we seen from the past few year experimental investigations conducted in this field.

The first question comes in mind that why water? As in recent days there are so many supplements are available for the water with better results. The reason to

choose water as working fluid is to minimize the manufacturing cost, it is not hazardous to human health and there are some application where water is the only option available like power plants, the amount used in the power plant is very huge to produce electricity and for this purpose heat transfer coefficient of water is need to reconsidered.

Chen (1996) was the first investigate the heat transfer in vertical tube for flow boiling and still there are series of works have been recently pursued at the Purdue University boiling and two- phase flow laboratory (PU – BTPFL) based on the methodology that were used to predict critical heat flux (CHF) for water in tube. The boiling process is categorized in two type pool boiling and flow boiling, pool boiling mechanism is easy to understand the key point for this study is concentrated on flow boiling. In boiling mechanism heat is transferred from heated surface to water but the bulk in contact with the surface is not the same hence is difficult to find the exact heat transfer rate to the flow boiling. There are so many researchers have done work on this before and some correlations are also developed by them to calculate the heat transfer coefficient directly.

Flow boiling involves bulk motion of liquid and buoyancy effect that is why generalized theories are not available for the flow boiling due to various flow complexities i.e. bubble growth, separation, coalescence, effect of flow hydrodynamics, velocities and the variation in the flow patterns of the two phase flow. Although two-phase flow maps are available for distinguishing the flow regions within two phase flows such as slug and bubbly flow in the pipe but it should be noted that the subject of flow transition between these regimes is an area of active research. so recent activity carried out in order to investigate the behavior of the flow boiling heat transfer in small diameter channels there is a still lack of information and reliable data of engineering design and application. Analysis of these earlier works shows that the major parameters affecting the HTC under flow boiling is heat flux saturation pressure and thermo-physical properties of the working fluid.

Designing of the heat treatment equipment is very complicated task and for calculating the exact heat transfer rate properties of the working fluid is very necessary to understand irrespective of the manufacturing cost and running cost. As the size of the equipments are

reducing day by day hence creating the major challenges for designers. For testing the heat transfer coefficient of the water the test section of copper with 1.5m and internal diameter of 8mm is used detailed view of the setup is given as below.

2. EXPERIMENTAL SCHEMATIC DIAGRAM

The figure 1 shows the schematic view of experimental setup, it consist of a test section with copper tube of length 1.5m and internal diameter of 8mm. There are thermocouples attached on the peripheral surface of the test tube at an angle of 90 to note temperature at that particular section T₁, T₂, T₃, T₄ respectively, similarly test section is divided in to four section so total 16 thermocouple are attached on test section for getting the surface temperature. The flexible heating coil with 3 kW is wrapped around the test tube to provide the uniform heating to the water inside the tube also to reduce the heat losses from test section to the atmosphere cotton fiber insulation is used to reduce these losses. A centrifugal pump with 20 ft of pumping height and it is located below the test section to get the constant flow rate and to avoid the problem of cavitations. A flow meter with 100 lph is attached to measure the flow rate which is controlled by flow controlling valve and by pass valve, with the help of both the valve flow rate is adjusted.

As water saturation temperature is not possible to achieve in test section for such a short length to overcome this problem pre-heater is used in to which temperature increased from room temperature to near the saturation temperature.

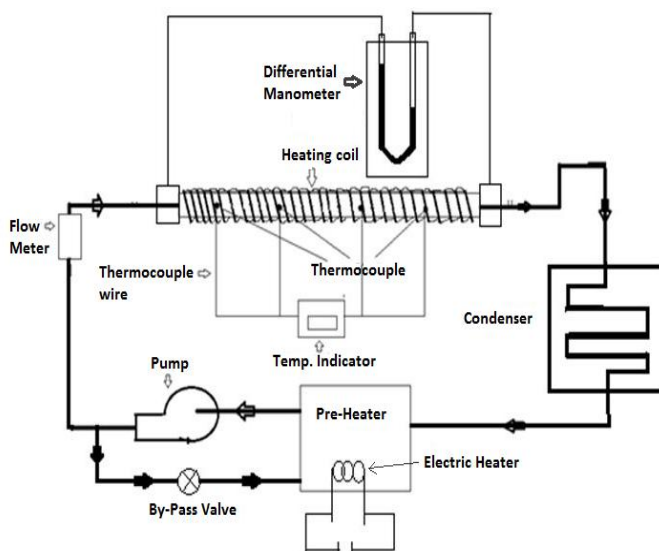

Fig 1: schematic diagram of experimental setup

The pressure drop across the test section is measured using the manometer which is made of acrylic with mercury and differential pressure gauge is also attached between the two points at inlet and outlet of the test section.

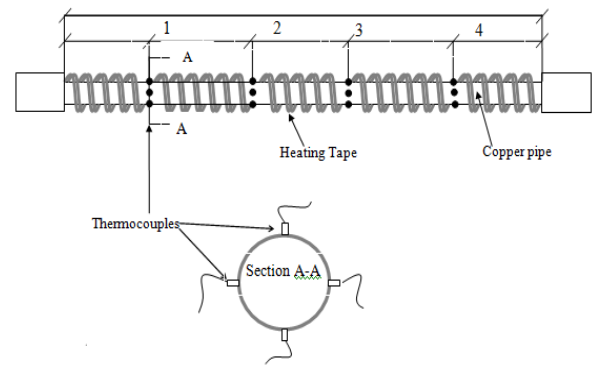

Fig 2: Detailed view of test section

2.1 EXPERIMENTAL PROCEDURE

The purpose of this experimentation is to determine the effects of different parameters like mass flow, heat flux on the heat transfer coefficient in the two-phase flow boiling. The detail of the facility is shown in the fig. The experimentation setup consists of different parts which are designed to vary the parameters in the different ranges so that number of readings can be taken. The main parts of the setup are pre-heater, centrifugal pump, flow meter, display board, condenser and test section.

As per the literature survey the parameter which affect the heat transfer most are heat flux and mass flux hence considering this test is divided in to two sets of reading. First heat flux provided on the surface of the test section is kept constant and mass flux is varied this procedure is followed for each heat flux which gives temperature and pressure readings for each conditions. Similarly for the second data set mass flux is kept constant and then heat flux is varied using the regulator.

3. DATA REDUCTION

At the very start of the experimentation test runs are taken with single phase and heat losses to the atmosphere is calculated using the heat loss calculation and efficiency of the heat transfer from heating coil to the water is calculated this will minimize the errors in last results the formula used for efficiency is as given below.

$$\eta = \frac{\dot{m}(h_{out} - h_{in})}{P} \quad (1)$$

where η is efficiency, \dot{m} mass flow rate of the water, P is the power supplies to the heating coil in W and h_{in} , h_{out} are the enthalpies of water at inlet and outlet of the test section at the particular pressure. For this particular setup we got the efficiency 92 % which will be used in further calculation.

The outcome of this experimentation are in the form of temperature, pressure, mass flux, heat flux and velocity this data is further reduced to calculate the final results. This data reduction for heat transfer coefficient is based on some considerations which are as follows.

-Heat transfer is taking place only in radial direction and it is neglected in axial direction.

-Heat flux is uniform along the test section due to volumetric heat generation.

-pressure drop along the inlet and outlet of test section is linear function of tube length.

The uncertainty associated with sensors used in the experimentation is estimated by considering accuracy of the different sensors as mentioned in the table.

Variable	Equipments	Accuracy	Range
Mass flow rate	Rotameter	±1 lph	0 to 100 lph
Temperature	Thermocouples	±0.03° C	0 to 300° C
Pressure difference	Pressure sensor	±0.05 bar	0 to 1
Voltage	Voltmeter	±0.2%	0 to 30 V
Current	Amperometer	±0.2%	0 to 220 A

Table 1: measuring instruments with accuracy %

Enthalpy at the inlet of the test section is calculated directly using steam table for the water at the corresponding temperature and pressure, enthalpies at the respective sections are calculated using the following equations.

$$H_1 = \left(\frac{q_1 \dot{m}}{\dot{m}}\right) + h_i \quad (2)$$

$$x_1 = H_1 + \frac{h_f}{h_{fg}} \quad (3)$$

where h_1 is the enthalpy at section 1, \dot{m} mass flow rate, x is dryness fraction and h_f , h_{fg} are enthalpies of fluid and mixture respectively at section 1 after adding the heat. Similarly the value of x is and enthalpy is calculated for all four sections

section 2

$$H_2 = \left(\frac{q_2 \dot{m}}{\dot{m}}\right) + h_1 \quad (4)$$

$$X_2 = H_2 + \frac{h_f}{h_{fg}} \quad (5)$$

section 3

$$H_3 = \left(\frac{q_3 \dot{m}}{\dot{m}}\right) + h_i \quad (6)$$

$$X_3 = H_3 + \frac{h_f}{h_{fg}} \quad (7)$$

section 4

$$H_4 = \left(\frac{q_4 \dot{m}}{\dot{m}}\right) + h_i \quad (8)$$

$$X_4 = H_4 + \frac{h_f}{h_{fg}} \quad (9)$$

Local heat transfer coefficient h is calculated using the formula

$$h = \frac{q'' \dot{m}}{T_{wi} - T_{sat}} \quad (10)$$

where h is the heat transfer coefficient, q'' heat flux supplied to the test section, T_{wi} is internal wall temperature and T_{sat} is the saturation temperature of the water at that pressure. Outside temperature of the tube is taken as mean value for all four temperature of thermocouple.

$$T_{wo} = \frac{T_{w,top} + T_{w,Rside} + T_{w,Lside} + T_{w,bottom}}{4} \quad (11)$$

Where T_w represents wall temperature and subscripts top, R side, L side, bottom represents top, right side, left side and bottom position temperature at each cross section along the test section. T_{wi} the inner wall temperature of the test section is calculated using one dimensional steady state heat conduction equation which is

$$T_{wi} = T_{wo} - \left(\frac{q D_i}{4k}\right) \left(\frac{(D_i/D_o)^2 - 2 \ln(D_i/D_o) - 1}{1 - (D_i/D_o)^2}\right) \quad (12)$$

4. RESULTS AND DISCUSSION

In the following section the results of the effect on heat transfer coefficient for different parameters i.e. heat flux, mass flux, pressure and dryness fraction is presented and discussed.

4.1 Heat transfer coefficient for constant heat flux and mass flux is varying

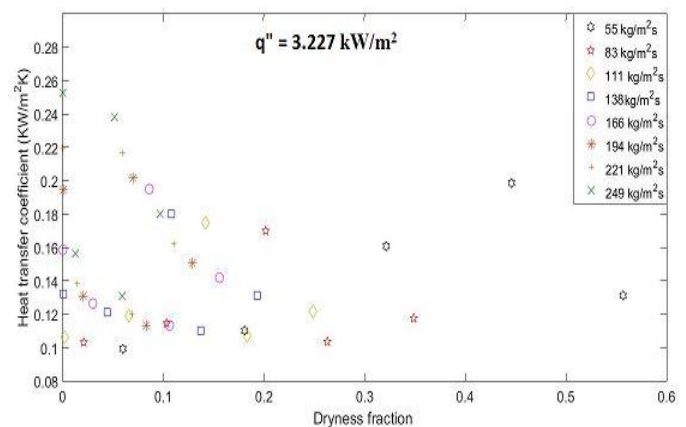

Fig 2: HTC for $q'' = 0.984 \text{ kW/m}^2$ and G is varying

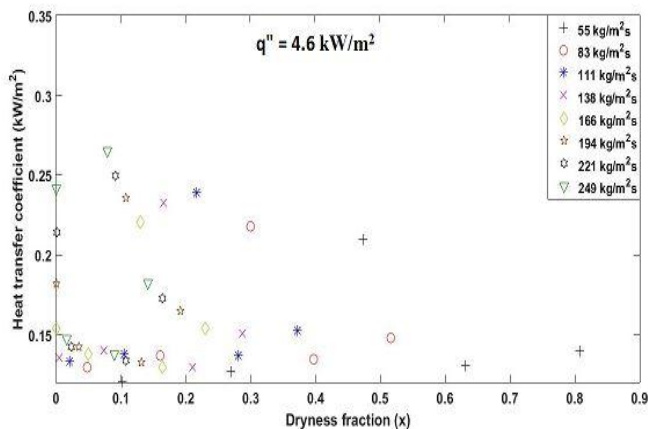

Figure 6.11: HTC Vs dryness fraction $q'' = 4.6 \text{ kW/m}^2$, and different mass flux

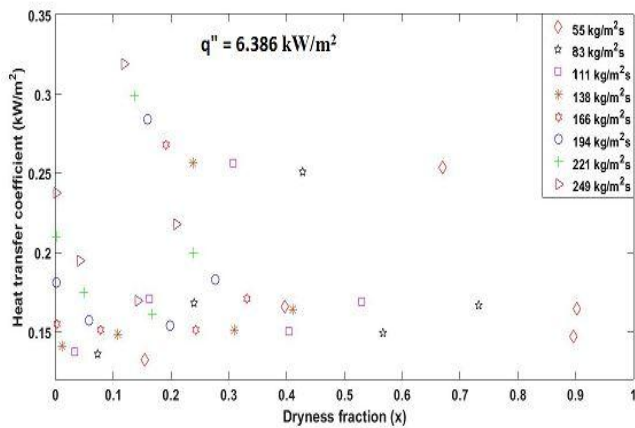

Figure 6.12: HTC Vs dryness fraction $q'' = 6.386 \text{ kW/m}^2$, and different mass flux

From the above results it is seen that with increase in the heat flux heat transfer rate is increasing with the quality content. The reason for this phenomenon is as the flow proceeds downstream and vaporization takes place, the void fraction is increases thus decreasing the density of the liquid vapor mixture. Result of this is flow is increases by enhancing convection transport from the heated wall of the tube. Results of the two is heat transfer coefficient at the point of transitions phase from nucleate boiling and convective is more.

The figure 6.8 to 6.13 it can be seen that there are significant effect in heat transfer coefficient for the variation of mass flu and constant heat flux. Out of these some result are very appropriate like 6.386 kW/m^2 and $111 \text{ kg/m}^2\text{s}$.

4.2 Heat transfer coefficient for constant mass flux and heat flux is varying

As the nucleate boiling diminishes the heat transfer coefficient start to decrease until it diminishes

completely. The convection boiling is characterized by the increase in the quality content the heat transfer coefficient is increase with

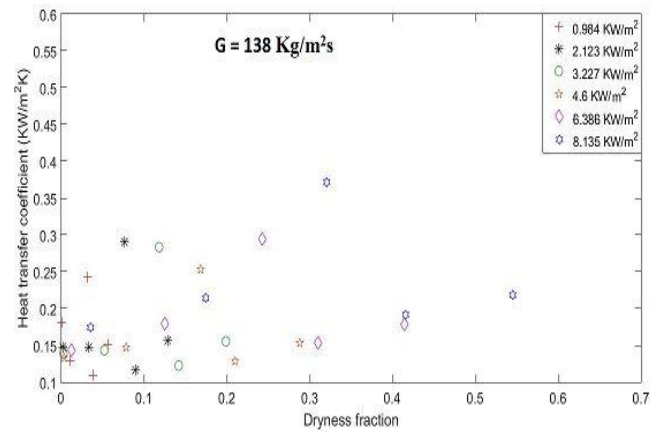

Figure 6.4: HTC Vs dryness fraction $G = 138 \text{ kg/m}^2\text{s}$, and different heat flux

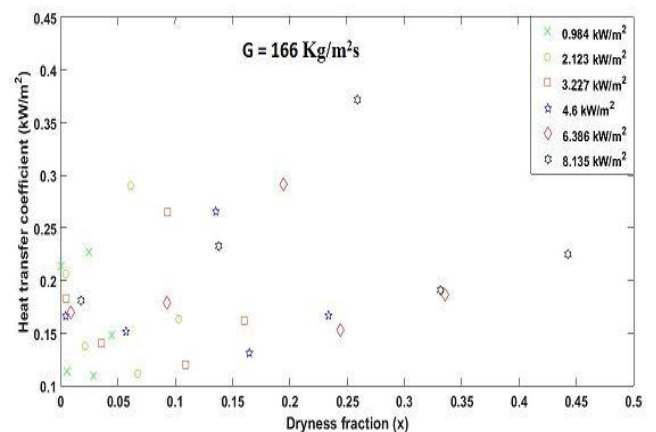

Figure 6.5: HTC Vs dryness fraction $G = 166 \text{ kg/m}^2\text{s}$, and different heat flux

increasing in the quality. This continues increase in heat transfer coefficient lead to the partial or totally dry-out condition, which affect the heat transfer coefficient hence convection graphs shows the decrease in heat transfer coefficient.

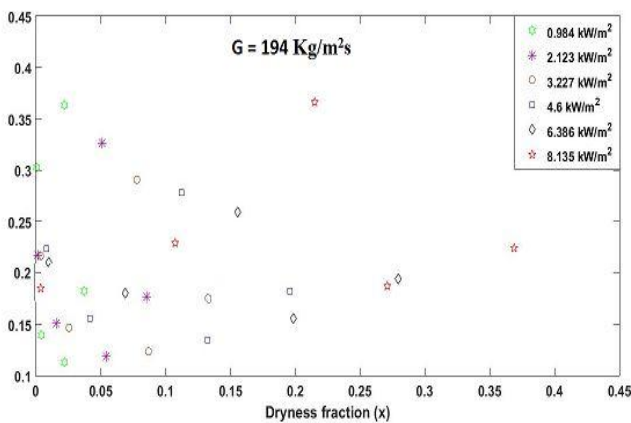

Figure 6.6: HTC Vs dryness fraction $G = 194 \text{ kg/m}^2\text{s}$, and different heat flux

3. CONCLUSIONS

The purpose of this study was to investigate the variation of heat transfer coefficient of water for different parameter, considering these parameter some results are plot from that following conclusions are made.

- The experimental results indicate that the heat transfer coefficient is increases with increase in the heat flux for same mass flux range when mass flux is varied for constant heat flux and its maximum value is achieved for the dryness fraction less than 0.2.
- For the value of dryness fraction 0 to 0.1 heat transfer coefficient is independent of mass flux there is negligible change occurred.
- Approximately 70% of the experimental data shows the minimum deviation of $\pm 20\%$ with the Kandlikar correlation for two phase flow where as data is under predicted for Chen correlation.

REFERENCES

- 1] Kandlikar S.G.(2004) "Heat Transfer Mechanisms during flow boiling in microchannels", journal of Heat Transfer, vol.126, pp.8-16.
- 2] Thome J.R.(2006) "stat of the art overview of boiling and two phase flow in microchannel", Heat Transfer Engineering,27(9),pp.4-19.
- 3] Lee J., Mudawar I.(2005) "Two phase flow in high-heat-flux microchannel heat sink for refrigeration cooling application: part I-pressure drop characteristics, part II-heat transfer characteristics", Int. Journal of heat and mass transfer, 48,pp.928-955.
- 4] Samuel M. Sami, Joseph D. Comeau(2002) "Influence of the thermo-physical on two-phase flow convective boiling of refrigerant mixture", applied thermal engineering 22, pp.1535-1548.

- 5] J. C. Chen(1966) "Correlation for boiling heat transfer to saturated fluids in convective flow," I&EC Process Design and Development, 5 (3), pp. 322-329.
- 6] M. M. Shah(1982)"Chart correlation for saturated boiling heat transfer: equations and further study," ASHRAE Transactions, 88, pp.185-196.
- 7] D.L. Bennett, M.W. Davies, and B.L. Hertzler(1980)"The suppression of saturated nucleate boiling by forced convective flow," American Institute of Chemical Engineers Symposium Series, 76 (199), pp. 91-103.
- 8] K. E. Gungor and R. H. S. Winterton(1986)"A general correlation for flow boiling in tubes and annuli," Int. J. Heat Mass Transfer, 29 (3), pp. 315-358.
- 9] S. G. Kandlikar(1990) "A general correlation for saturated two-phase flow boiling heat transfer inside horizontal and vertical tubes," J. Heat Transfer, 112, pp. 219-228.
- 10] D. Steiner and J. Taborek(1992)"Flow boiling heat transfer in vertical tubes correlated by an asymptotic model," Heat Transfer Engineering, 13 (2), pp. 43-68.
- 11] Arjit Kundu, Ravi Kumar and Akhilesh Gupta(2014) "Flow boiling heat transfer characteristics of R407C inside smooth tube with different tube inclinations." International journal for refrigeration 45,pp I-12.
- 12] Wojtan, Ursenbacher, Thome(2005) "Investigation of flow boiling in horizontal tube: part II-development of new heat transfer model for stratified wavy, dry-out and mist flow regimes", Int. journal of heat and mass transfer48, pp.2970-2985.

Appendix Notation

A	Heat transfer area (m ²)
C _p	specific heat at constant pressure (J/kg K)
\dot{m}	mass flow rate (kg/m ² s)
P	pressure (Pa)
T	temperature
K	thermal conductivity (W/m K)
q"	heat flux (W/ m ²)
Q	heat transfer rate (W)
x	vapor quality
H	heat transfer coefficient (W/ m ² K)
ΔP	pressure drop
Re	Reynolds number
d	diameter of pipe (m)
l	length of test section (m)

Greek symbols

f	friction factor
Φ	two phase multiplier
η	efficiency
ρ	density (kg/m ³)

μ dynamic viscosity (pa s)

Subscripts

tp test pipe
ph pre-heater
i internal
wi inner wall
sat saturation
G vapor
L liquid
h enthalpy