

## LIFE SAVING DEVICE: A SMART HELMET

Kshirsagar Rajat<sup>1</sup>, Fakir Swaleha<sup>2</sup>, Thombre Shubham<sup>3</sup>, Prof. Apte S.K<sup>4</sup>

<sup>1, 2, 3</sup>BE in Electronics and Telecommunication Engg.SGI, Kolhapur (Atigre), Maharashtra, India.

<sup>4</sup>Professor Apte S.K, Dept. Of Electronics and Telecommunication Engineering, SGI, Kolhapur (Atigre) Maharashtra, India.

\*\*\*

**Abstract** - The aim of this unique helmet is to provide Safety to the bike rider. With the help of Proper Switch Mounted in helmet the two-wheeler would not start without helmet so safety of rider is assured and if accident has occurred our system will give information to the ambulance about the accident, so they can take certain measures to save the life of the person who meet with an accident. It is developed using Arduino. We place sensors in numerous sides of helmet that is connected to Arduino board. So once the bike rider crashes sensors sense and therefore the Arduino extract Global Positioning System (GPS) location information from GPS that is interfaced with Arduino. When the device information exceeds most limit of pressure then Global System for Mobile communication (GSM) module will send message to ambulance, police or family members. In case of minor injuries, the rider can stop message by the SMS stop switch. We also introduce one unique feature for ignition the bike engine when helmet is stolen.

**Key Words:** Arduino mega2560, Arduino Uno R3, GSM SIM900, GPS receiver, Adxl335, MQ3 sensor, HC05 Bluetooth sensor.

### 1. INTRODUCTION

In recent times helmets have been made compulsory in Maharashtra State. Accidents in India have increased day by day. As per Section 129 of motorized vehicles Act, 1988 makes it needed for each single riding a two-wheeler to wear protecting headgear following to standards of the BIS (Bureau of Indian Standards). Drunken drive case could be a criminal offence of the car act 1939. This states that the bike rider can get penalized. In existence bike rider simply get free from law. These are three main problems that

motivates for developing this project. The first step is to check the helmet is wear or not. If helmet is wear then ignition can begin otherwise it'll remains off until helmet isn't wear. For these we use pressure sensor. The second step is alcohol detection. Alcohol detector (MQ3) is use as breath instrument that observe the presence of alcohol in rider breathe if it's exceeds permissible vary ignition cannot begin. When these 2 conditions are true then ignition can begin. The third main issue is accident and late medical facilitate. If the rider met accident with him he cannot receive medical facilitate instantly, it is huge reason for deaths. Around each second persons die because of late medical facilitate or the accident place is unmanned. In fall detection, we place GSM and GPS module at this unit. Due to these mechanisms we can observe that accident happens or not. The aim of this project is to create a protection system in a helmet for a better safety of motorcycle rider. The sensible helmet that we created is sense that helmet wear or not. There are two Arduino are placed in this this project as a processor. Each unit has used a separate processor, for bike unit we use Arduino mega 2560 and for helmet unit we use Arduino uno. Signal transmission between the helmet unit and bike unit is established by RF trans receiver.

### 2. Literature survey

The thought of developing this paper comes from the accident which occurs in our daily life. As we can see many accidents occurring around us; there is lot of loss of life. According to survey, many people die in road accidents occurring due to bike crashes per year. The reason for the accidents may be such as no proper driving knowledge,

damaged bikes, rash driving, drunken drive etc. But the major reason was found to be the absence of helmet on that persons head, resulting in an immediate death due to brain damage.

Gunprabh Chadha, et al. [1] described that to overcome the accidental situation, a security system has been embedded within the "Smart Helmet" and this circuit is placed within the helmet. If helmet is not buckled the bike will not start. An alcohol level detector is additionally placed within the circuitry. If the rider has consumed alcohol the vehicle cannot turn on. Also when an accident takes place a message will be sent to the pre-stored numbers. Prof. Chitte P.P. et.al. [2] Said that if helmet is wear then ignition will start otherwise it'll remain off until helmet isn't wear. For these we use FSR sensor. The second step is alcohol detection. Alcohol sensing element is use as breath analyser that detect the presence of alcohol in rider breath if it's exceeds permissible range ignition cannot start. It will send the message to register number. MQ-3 sensor is used for these. When these two conditions are satisfied then ignition will start. Mr. Vivek A. Patel, et.al. [3] described that their helmet ensures that the rider has wore the helmet and he/she has nonalcoholic breath and if accident has occurred it will inform the ambulance on time even there is no person to give information of the accident to the ambulance. Rambabu et.al. [4] Focused on an optimal Driving System with the help of Wireless Helmet. They has used a wireless communication between bike to helmet and bike to traffic light and speed breaker. The system is comprised of a helmet module together with stereo speakers and microphone, and a motorcycle mounted base unit. The system will make use of different wireless communication protocols together with ZigBee and another frequency (RF) protocol. Sudharsana Vijayan, et al. [5] described the alcohol Detection with sensible Helmet System, here they used a switch which detect whether rider is wear helmet or not. Alcohol sensing element is employed to notice the biker is drunk; the output is fed to the MCU. If any of the 2 conditions are dissatisfy

then the engine won't turned ON. Manjesh N, Prof., et al. [6] focused on Smart Helmet Using GSM & GPS Technology for Accident Detection and reporting System. The idea of this work is to give information concerning the rider carrying the helmet or not, whether the biker drunken or not and if accident occurs then through GSM & GPS module the location of biker will send on particular mobile numbers. In this system P89V51RD2 microcontroller is used. In this paper they used Vibration sensing element, Alcohol sensing element, Temperature Sensor & Solar Cell as power supply. R. Pruthvi Raj, et.al. [7] Researched about Smart-Tec Helmet. The prototype has three inputs and as many outputs routed to and from the P89V51RD2 Microcontroller respectively. The two sensors incorporated in the prototype one is LM35D temperature sensor and ADXL3 tilt sensor, along with the GSM and Global Positioning System; module comprised the input circuitry while the Peltier module, the LCD module and also the international System for Mobile communications (GSM) module forms the output circuitry. K. Sudarshan, et.al. [8] described that people need to wear helmet and to prevent road accidents. Thus road accidents prevented to some extent and safety of motorbike riders is ensured. Vijay, B. Saritha, et.al. [9] Said that the system efficiently checks the wearing of helmet and drunken driving. By implementing this technique a secure 2 wheeler journey is feasible which might decrease the pinnacle injuries throughout accidents and conjointly cut back the accident rate due to drunken driving. Harish Chandra Mohanta et.al. [10] Described the embedded safety and security system for vehicle by integrating and modifying existing modules. This system endures primarily with 3 modules specifically Gas sensing module, Obstacle detection module and Anti-Theft alert system; this square measure interfaced with ATmega16 microcontroller. Wilhelm von Rosenberg, et.al. [11] Focused on Smart Helmet: Monitoring Brain, Cardiac and Respiratory Activity. In this paper they have obtained a ballistocardiogram and a single lead ECG from sensors is placed behind the ear showed the possibility

to collect cardiac data non-invasively from head locations. Prof. N. B. Kodam [12] described data about the rider wearing the cap or not, whether the rider smashed or not furthermore. It included block diagrams of bike unit and helmet unit. A. Srikrishnan et.al. [13] Focused on Cloud Incorporated Smart Helmet Integrated with Two-wheeler Communication Setup. The entire system is followed into two halves: (a) Helmet System (b) Vehicular System. Reported works in the field of Helmets include, the usage of RF technology to detect crash and notify to the control room. Vibration Sensors placed on the helmet to check the vibration. Aviral Ajay, et al. [14] focused on GSM module which is used with microcontroller and transmitter circuit. Piezo sensor is used to sense the vibration. It included the block diagram of GPS and GSM module and also block diagram of accidental free transportation system. Saravana Kumar K et.al. [15] published a paper on Smart Helmet. This paper on "Smart Helmet" basically it used three main modules called Helme system module, voice recognition module, Bike system module. The helmet can be used to communicate with the bike module all the time during the riding to detect if the person is wearing the helmet or not and then the bike module or processor is asked for a password in the form of speech to unlock the bike by matching a user-unique password. Jennifer William et.al. [16] Published Intelligent Helmet. The proposed system is an intelligent helmet. The system ensures the safety of the biker. This system also detect the helmet is stolen or not and send signal to proposed processor to further processes. **3.**

**Methodology**

There are two Arduino are placed in this this project as a processor. Each unit has used a separate processor, for bike unit we use Arduino mega and for helmet unit we use Arduino uno. Signal transmission between the helmet unit and bike unit is established by RF transreceiver. We also implement the HC05 Bluetooth sensor in emergency condition, if helmet is stolen then every user having a unique

self-generated password which can be used to unlock the bike ignition model and start the bike. The technology used in it is wireless and is completely same for long usage. Once activated the transmitter sends a some signal to the receiver circuit and hence there is some time lag in wearing the helmet and switching on of the circuit large scale production solid state relays is place to use which have higher response. The sensible helmet mentioned in this paper is depends on one single idea that is to make it somehow necessary to wear it when riding a bike by the assistance of some technology. This helmet in observes acts as a second key to the vehicle and successively will increase security. Moreover because the rider will neither starts nor run the vehicle without wearing the helmet it ensures that the rider should wear the helmet always while riding the vehicle.

**4. Proposed System**

**4.1 Proposed system in Helmet**

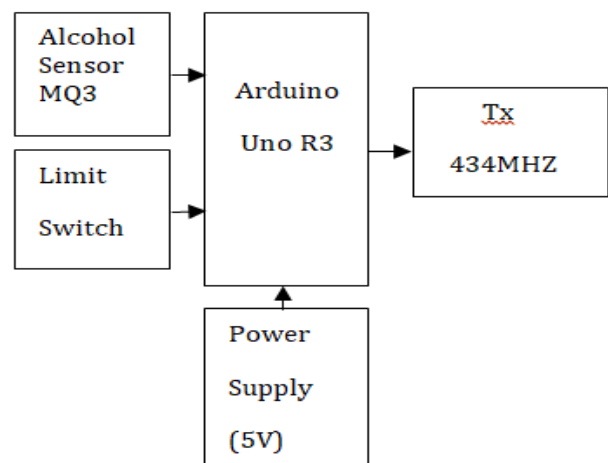

Figure1: block diagram of transmitter section

Figure.1 shows block diagram of transmitter section helmet module. We are used here Arduino Uno R3 as a main processor. Alcohol sensor (MQ3) is used to detect the content of alcohol from the user's breath. Alcohol sensor (MQ3) is placed near the mouth of the rider. Pressure sensor can sense the presence of helmet. If helmet is not buckled then this sensor send fall signal to the Arduino uno and

further process is proceed by transmitter section. It requires 5V power supply. All the data is then send to the receiver section.

#### 4.1 Bike Module System

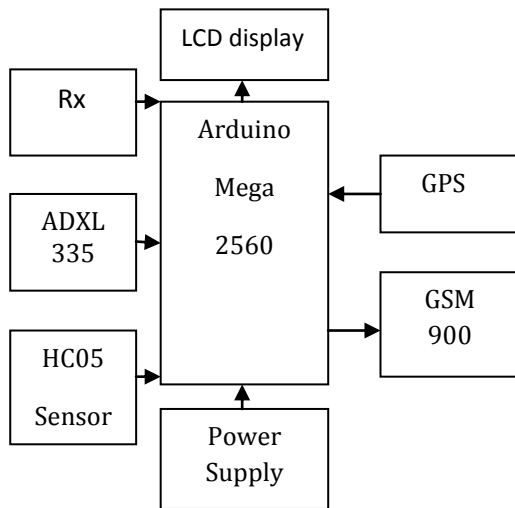

Figure2: Block diagram of receiver section

Figure.2 shows block diagram of receiver section bike module. In bike module, we used here Arduino mega 2560 as a main processor. Receiver collects all the data and then an LCD display the result whether helmet is wear or not also it shows that rider drunken or not. In emergency cases helmet is get stolen then we can use Bluetooth sensor as an alternative process for engine start. GPS receiver is used to show the location of the rider if accident occurs and it will send message to registered mobile number and ambulance.

#### 4.2 Working principle

The thought of doing this project is to provide safety to bike rider while riding, if accident occurs then the arduino processor will send text sms to the registered mobile number using gsm gps. This is done by using the GSM module. We are using SIM808 as the GSM module. When the accident has happened the Tilt sensors sense the accident and give signal to the Arduino. Then Arduino can take location from the GPS and it will send the location of accident in the form of the latitude and longitude but normal user can't understand how get location from the latitude and longitude so we have implemented our system to send the google map link. Which will open in location maps, family members and the ambulance can take certain actions to save the life of biker. But we don't need to call ambulance every time. Sometimes the biker has minor injuries but piezo

electric sensor will sense that as accident. In this case bike rider can stop sending of the SMS. This is done by using the pressing switch to stop accident. Before sending the accident message to the ambulance and family members the buzzer will ring for the 40 seconds if the bike rider has minor injuries then it can stop the sending of the SMS by pressing the switch on helmet. Above system mentioned was for the accident reporting. This is done by using the MQ3 sensor and the Rider detection switch. The vehicle part contains the Arduino mega and other circuit to start or stop the ignition

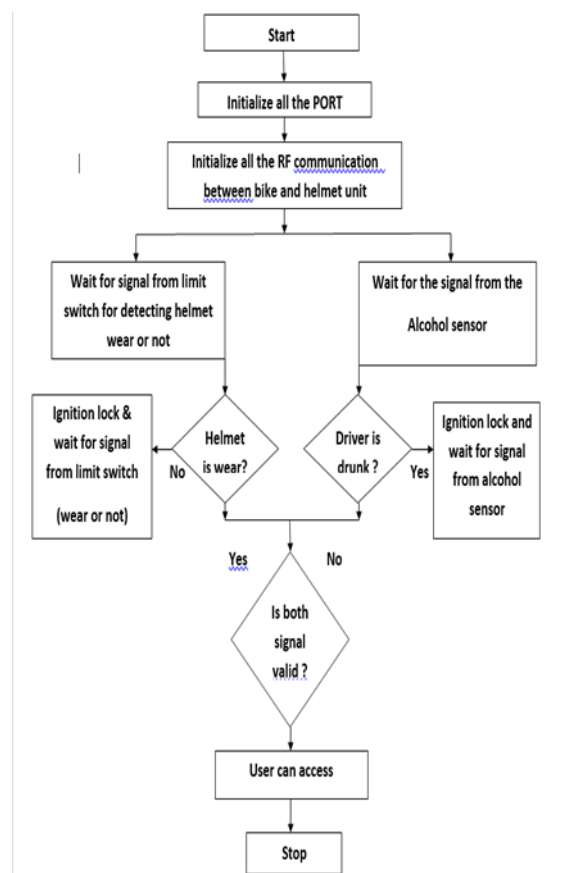

Figure3: Flowchart of Smart Helmet

#### 5. Future scope

- We can implement numerous bioelectric sensors on the helmet to detect various activities.
- We can use camera for the shooting and recording the rider's activity.
- It can be used for passing message from the one vehicle to a different vehicle with the help of wireless transmitter.

- We can use solar energy for helmet power supply and same power supply will charge our mobile
- It can be used for location tracking.
- GPRS may be used for the storing information online.
- GPS can be programmed to calculate the speed of the bike in case of more speed.

## 6. Conclusion

In paper, we represented a smart helmet based system which will successfully able to detect whether the rider as worn the helmet or not. It also sets an alcohol sensor rider has consumed alcohol beyond permissible levels. This helmet will overcome the range of road accidents that takes place each day. If accident occurs it will sends the victim's location to family members and nearby police station. Also, death rate can drastically be reduced by implementing this circuit as mandatory while riding and make everyone's life easier and smoother. We also implement a new feature like Bluetooth controlled bike starter. The project can be increased by adding Google Glass Technology. Also, biker will see navigation and it alert him when taking sharp turns. Further, it can implement on cars also.

## REFERENCES

- [1] Gunprabh Chadha, Brij Kanodia and Vishal Lakhani, "SMART HELMET", International Research Journal of Engineering and Technology (IRJET), ISSN: 2395-0056, volume 3, issue 2, Feb 2016
- [2] Prof. Chitte P.P. , Mr. Salunke Akshay S. , Mr. Thorat Aniruddha N., Mr. Bhosale Nilesh T, "SMART HELMET& INTELLIGENT BIKE SYSTEM", International Research Journal of Engineering and Technology (IRJET), ISSN: 2395-0056 Volume 3, issue 5, May-2016.
- [3] Mr. Vivek A. Patel, Mr. Akash Mishra, and Mr. Rana Hiten, Mr. Kautik Prajapati, "SMART HELMET", International Research Journal of Engineering and Technology (IRJET), ISSN: 2395-0056, Volume 4, Issue 4, Apr -2017
- [4] K. Rambabu, B. Premalatha, C. Veeranjaneyulu, "AN OPTIMAL DRIVING SYSTEM BY USING WIRELESS HELMET", International Journal of Science, Engineering and Technology Research (IJSETR), ISSN: 2278-7798, Volume 2, Issue 9, September 2013
- [5] Sudharsana Vijayan, Vineed T Govind, Merin Mathews, SimnaSurendran, Muhammed Sabah, "ALCOHOL DETECTION USING SMART HELMET SYSTEM", International Journal of Emerging Technology in Computer Science & Electronics (IJETCSE) ISSN: 0976-1353 volume 8, issue 1, APRIL 2014.
- [6] Manjesh N, Prof. Sudarshan Raj, "SMART HELMET USING GSM & GPS TECHNOLOGY FOR ACCIDENT DETECTION AND REPORTING SYSTEM" International Journal of Electrical and Electronics Research ISSN:2348-6988 Vol. 2, Issue 4, pp: (122-127), Month: October - December 2014, Research Publish Journals
- [7] R. Prudhvi Raj, Ch. Sri Krishna Kanth, A. BhargavAdityaand K. Bharath, "SMART-TECH HELMET" Advance in Electronic and Electric Engineering, ISSN: 2231-1297, Volume 4, Number 5 (2014).
- [8] Sudarsan K and Kumaraguru Diderot P "Helmet for Road Hazard Warning with Wireless Bike Authentication and Traffic adaptive Mp3 Playback", International Journal of Science and Research (IJSR), Vol. 3, No. 3, ISSN (Online): 2319-7064. (2014),
- [9] Vijay J, Saritha B, Priyadharshini B, Deepeka S and Laxmi R, "Drunken Drive Protection System", International Journal of Scientific & Engineering Research, Vol. 2, No. 12, ISSN: 2229-5518. (2011),
- [10] Harish Chandra Mohanta, Rajat Kumar Mahapatra and Jyotirmayee Muduli", Anti-Theft Mechanism System with

Accidental Avoidance and Cabin Safety System for Automobiles”, International

Refereed Journal of Engineering and Science (IRJES), Vol. 3, No. 4, pp. 56- 62, (2014).

[11] Wilhelm von Rosenberg, Theerasakhanwimalueang, Valentin Goverdovsky, Danilo P. Mandic “SMART HELMET: MONITORING BRAIN, CARDIAC AND RESPIRATORY ACTIVITY”, IEEE 2015.

[12] N. B. Kodam “SMART HELMET (NO BIKE RIDING WITHOUT HELMET)” (IRJI) International Research Journal of India, ISSN: 2454-8707 VOLUME-I, ISSUE-I, SEPT-2015.

[13] A. Srikrishnan, K. Senthil Kumar and S. Ravi CLOUD INCORPORATED SMART HELMET INTEGRATED WITH TWO-WHEELER COMMUNICATION SETUP, I J C T A, pp. 251-261, 2016.

[14] Aviral Vijay, Ajay Singh, Abhimanyu Yadav, Blessy Varghese and Ankit Vijay, “HI-TECH HELMET AND ACCIDENTAL FREE TRANSPORTATION SYSTEM”, International Journal of Advanced Technology and Engineering Exploration, ISSN 2394-5443, VOLUME-2, ISSUE-6 MAY-2015.

[15] Saravana Kumar K, Anjana.B.S, Litto.Thomas, Rahul.K.V, “SMART HELMET”, International Journal of Scientific & Engineering Research, Volume 7, Issue3, March-2016.

[16] Jennifer William, Kaustubhpadwal, Nexonsamuel, Akshay bawkar, smita rukhande “INTELLIGENT HELMET”, International Journal of Science, Engineering and Technology Research (IJSETR), volume 5, issue 3, march 2016