

# Contactless Energy Generation Using Flywheel

Akhil Bhat<sup>1</sup>, Shrikrushna Borbale<sup>2</sup>, Prof. S.H. Joshi<sup>3</sup>

<sup>1</sup>UGScholar Dept. of Mechanical Engineering, ZCOER, Pune, Maharashtra, India

<sup>2</sup>UGScholar Dept. of Mechanical Engineering, ZCOER, Pune, Maharashtra, India

<sup>3</sup>Assistant Professor, Dept. of Mechanical Engineering, ZCOER, Pune, Maharashtra, India

\*\*\*

**Abstract** - This Paper represents the investigation of free energy using flywheel arrangement. The energy lost due to the friction in dynamo is utilised to generate free energy. This extra free energy is used to run other electrical devices. It comprises of A.C. engine of half strength limit which is utilized to drive an arrangement of belt and pulley drive which in turn rotates the shaft on which the wheel is mounted. The interesting thing about this framework is that more prominent electrical yield power can be acquired from the alternator that gives off an impression of being drawn from the information engine. It is finished with the assistance of Gravity wheel. The gravity wheel or flywheel is combined with the rigging train so as to create free energy. This free energy is free of cost.

## 1. INTRODUCTION

The flywheel is an old method for conserving vitality and smoothing out power varieties. The potter's wheel and turning wheel are instances of uses of flywheels. The spotlight in this review is on applications where flywheels are utilized as a critical halfway vitality in car applications. This is a mechanical device which uses the flywheel to store energy in the form of inertia. In this system we applied an additional energy source to start the main motor like electricity. In this system main motor is used to drive a series of pulley and belt arrangement which forms a gear train arrangement which produce a twice/thrice speed at the shaft of generator. The significant thing about the system is that the electricity generated at the output of the shaft is more than that of input. The inertia of flywheel can be increased by increasing the radius of flywheel and weight of flywheel. It also increase if the flywheel weight is concentrated as far out toward the rim of the flywheel as is possible. Firstly, the requirement for an effective system needs to be a suitable flywheel with a large diameter and vast majority of the weight needs to be close to rim. The construction needs to be robust and secure as ideally. The rate of rotation will be as high as possible as the weight on the flywheel is concentrated outward of the rim which needs to be exactly at right angles to the axle on which it rotates and exactly centered on the axle. The main motor is at low speed, low voltage input motor, the generator is high speed, and high voltage output generator. Therefore, when we apply an extra energy to the main motor it starts running, which causes to rotate the flywheel. When the motor is reaches the highest speed (constant speed) we switch the power by applying the electrical energy generated by the generator. We add the extra thing in the system like transformers, rectifier, inverter etc. to run the system and take the efficiency output. Electric trains, autos, and other electric vehicles are fueled by electric engines associated with batteries. When we're driving along, vitality streams from the batteries to the engines, turning the wheels and providing us the kinetic energy to move. When we stop and hit the brakes, the entire procedure goes into u invert: electronic circuits slice the power to the engines. Presently, our active vitality and force makes the wheels turn the engines, so the engines work like generators and begin creating power as opposed to devouring it. Power streams once again from these engine generators to the batteries, energizing them. So a decent extent of the vitality we lose by braking is come back to the batteries and can be reused when we begin off once more. By and by, regenerative brakes set aside effort to back things off, so here our system zero friction no physical contact of vehicle connected, the flywheel plate just connected parallel with the type shaft to get the good output continuously even when there is braking.

## 2. PRINCIPLE OF OPERATION

Flywheel stores energy in a rotating mass. Depending on the inertia and velocity of the rotating mass, a given quantity of kinetic energy is saved as rotational energy. The quantity of energy stored in a flywheel is proportional to the square of its rotational speed. The way to change a flywheel's stored energy is with the aid of increasing or lowering its rotational speed applying a torque aligned with its axis of symmetry. As the flywheel rotates magnetic field is induced in the copper coils due to the magnet-coil arrangement as per Ampere's law. Also, an emf is generated in the coils.

### 3. METHODOLOGY

We have used the wheel of cycle which is linked to the pulley installed on the same shaft and its diameter is less than the wheel diameter due to which its velocity of rotation will be increased. On another shaft connected to the pulley is having the assembly of flywheel and neodymium magnet-coil arrangement. Flywheel will save the kinetic energy while wheel is in running condition and will release the K.E when the brake is applied on the wheel. So the use of flywheel offers such variety of energy which assists to run the cycle by less efficient power. Neodymium magnet will start rotating shaft and coil is steady. So right here variable e.m.f is produce from magnet and coil arrangement. By this way electricity will be generated and stored into battery

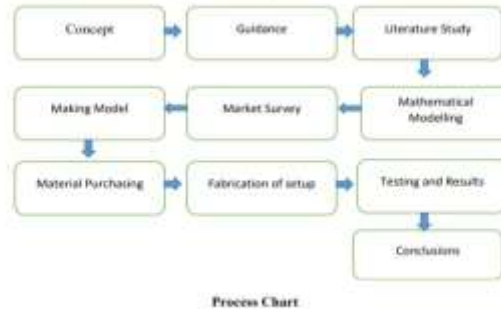

Fig. 1: Process Chart

### 4. COMPONENTS

#### 4.1 Neodymium Magnets

The Neodymium metal component is originally separated from refined Rare Earth oxides in an electrolytic furnace. The "Rare Earth" factors are lanthanides (also known as lanthanides) and the term arises from the unique oxide minerals used to isolate the elements.

Table no.1: Magnetic Material and Properties

	Typical Shapes	Pros	Cons
<b>Material</b> Cast Alnico AlNiCo	Rods, Bars, U shape and other cast types	High working Temp, Good Temp coefficient	Very low Hc High cost High L/D Requires cast
Sintered Alnico AlNiCo	Powder pressed to shape	Complex shapes High Br, T	Requires tool High cost Low market
Ceramic/Ferrite SrFe2O3	Blocks, Rings, Arcs, Discs	Most flux High usage Low corrosion	Most flux High usage Low corrosion
Neodymium NdFeB	Blocks, Rings, Arcs, Discs, Segments	Highest magnetic properties	Corrodes Low working T
Highest magnetic properties No tooling	Difficult geometries ca be insert moulded or over-moulded	No tooling Complex shapes Various resins	High tooling Low magnetics High Volumes

- o **Dimensions:** 25mm Diameter x 3mm thick
- o **Magnetic Face;** 25mm diameter
- o **Magnets Type;** Neodymium
- o **Material:** NdFeB,
- o Grade: N52
- o **Plating /Coating:** Ni-Cu-Ni (Nickel)
- o **Magnetization Direction:** Axial/radial(Poles on Flat Ends)
- o **Max Operating Temp:** 176°F (80°C)
- o **Quantity:** 08 pcs

#### 4.2 Material Selection of Flywheel

Flywheels are made from many exceptional materials; the utility determines the desire of material. Small flywheels made of lead are found in children’s toys. Cast iron flywheels are used in historical steam engines. Flywheels used in vehicle engines are made of forged or nodular iron, metal or aluminium Flywheels made from high-strength steel or composites have been proposed for use in automobile energy storage and braking systems.

<b>Function</b>	Flywheel for energy storage
<b>Objective</b>	Maximize kinetic energy per unit mass
<b>Constraints</b>	(a) Outer radius fixed (b) Must not fracture

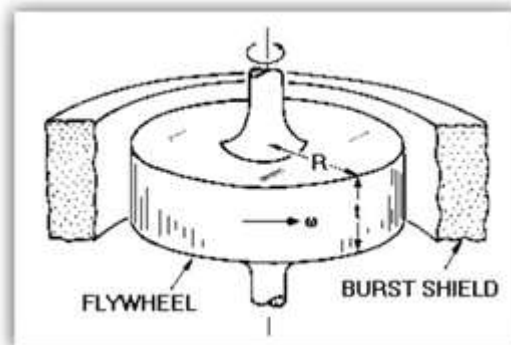

Fig. 2: A flywheel for energy storage.

#### 4.3 The Selection

From the following chart flywheel is selected of following  
 Specification: Material: MS  
 Density: 7860 kg / m<sup>3</sup>  
 Diameter: OD = 16 cm, ID = 24 cm, t = 12 mm

Material	M5(kj/kg)	Comments
Ceramics	200-2000	Brittle and weak in tension
Composites: CFRP	200-500	A good choice
Composites: GFRP	100-400	Almost as good as CFRP and cheaper
Beryllium	300	The best metal but expensive and difficult to work and toxic to machine
High Strength Steel	100-200	all about equal in performance. Steel and alloys cheaper than Mg and Ti.
High Al alloys	100-200	All about equal in performance. Steel and alloys cheaper than Mg and Ti.

Table no.2: Standard material for flywheel

Where  $J = \pi\rho R^4 t/2$  is the polar moment of inertia of the disc and  $\rho$  is the density of the material. Therefore the power stored is

$$U = \frac{\pi}{4} \rho R^4 t \omega^2$$

The mass of the disc is  $m = \pi R^2 t \rho$

The volume to be maximized is the energy per unit mass which is the ratio of the last two equations:  $\frac{U}{m} = \frac{1}{4} R^2 \omega^2$

As the flywheel is spun up, the electricity saved in it increases, but so does the centrifugal stress. The maximum principal stress in a spinning disc of uniform thickness is:

$$\sigma_{max} = \left( \frac{3+\nu}{8} \right) \rho R^2 \omega^2$$

Where  $\nu$  is Poisson's ratio. This stress must not exceed the yield strength (failure strength)  $\sigma_y$ , with a factor of safety,  $S$ . This sets an upper limit to angular velocity,  $\omega$ , and disc radius,  $R$ . Eliminating  $R\omega$  between the final two equations gives

$$\frac{U}{m} = \left( \frac{2}{S(3+\nu)} \right) \left( \frac{\sigma_y}{\rho} \right)$$

Poisson's ratio,  $\nu$ , is roughly  $1/3$  for solids and can be treated as a constant. The excellent materials for high-performance flywheels are therefore those with high values of the overall performance index

$$M_5 = \frac{\sigma_y}{\rho}$$

$M_5$  has units of  $\text{kJ/kg}$ .

#### 4.4 COILS

An electromagnetic curl is an electrical conduit, for example, a wire as a loop, winding or helix. Either an electric flow is outperformed through the wire of the loop to produce an attractive field, or on the other hand an outer time-shifting attractive territory by means of the inside of the curl creates an EMF (voltage) in the conductor. A current through any conductor makes a circular attractive field around the conductor because of Ampere's law. The benefit of utilizing the loop

structure is that it will grow the vitality of attractive field created by methods for a given current. The attractive fields created by methods for the different turns of wire all go through the focal point of the loop and include (superpose) to deliver a hearty field there

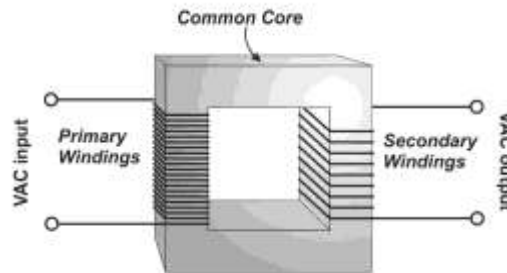

Fig. no. 3: Coils

The course of the attractive field created by a curl can be chosen by means of the correct hand hold rule. On the off chance that the fingers of the correct hand are folded over the attractive center of a curl toward customary current by means of the wire the thumb will point toward the path the attractive field lines pass through the loop.

### 5. DESIGN CALCULATIONS

1. Belt drives transmission:

- Motor RPM = 1440 (standard motor)
- Motor pulley Diameter (Input) = 75mm
- Large pulley Diameter (output) = 85mm
- Centre Distance = 250mm
- Output Rpm = to find

**Formula:**

$$\frac{\text{RPM of Motor}}{\text{RPM of shaft 1}} = \frac{\text{Diameter of shaft pulley}}{\text{Diameter of Motor pulley}}$$

- 1440/RPM of shaft 1 = 85/75
- RPM of shaft 1 = 1270.58
- RPM of shaft 1 = N2 = 1270.58

2. Chain drives transmission:

- Rpm output of belt drive is input rpm of chain drive therefore,
- Large sprocket RPM = 1270
- Large Sprocket diameter = 120mm Small Sprocket diameter = 80mm Large sprocket teeth (input) = 22
- Small sprocket teeth (output) = 14
- Centre Distance = 400mm Chain length = 1000mm

**Formula:**

$$\frac{\text{RPM of Shaft 1}}{\text{RPM of shaft 2}} = \frac{\text{No of teeth on larger pulley}}{\text{No of teeth on smaller pulley}}$$

- 1270/RPM output = 22/14

RPM output = 808

Hence the input speed of 1440 RPM is converted to 808 RPM to flywheel through a belt drive and chain drive.

According to design Magnets will also rotate with same speed as flywheel.

## 5.1 BEARINGS

From the Calculation we got the shaft diameter which is 20mm, accordingly we have selected the standard bearing no. P204.



Fig. no. 4: P204 Bearing

## 6. POWER GENERATION

When planning a generator it is basic to have a firm hold of the essential laws that oversee its exhibition. So as to set off a voltage in a wire a near to modifying attractive field must exist. The voltage encouraged not just depends upon on the size of the field thickness yet in addition on the loop region. The connection between the region and field thickness is related as motion ( $\Phi$ ). The manner by which this motion fluctuates in time relies on the generator plan. The pivotal motion generator utilizes the adjusting attractive transition to create a voltage. The voltage created through each loop can be determined utilizing Faraday's law of enlistment:

$$v = -N \frac{d\phi}{dt}$$

## 7. COIL DESIGN

The quantity of windings per loop creates a design challenge. The more windings will intensify the voltage created by methods for each curl yet thusly it will likewise extend the extent of each loop. In order to minimize the dimension of every coil a wire with a larger size gauge can be utilized. Again some other challenge is presented, smaller the wire will tend to pass minimum current and also due to the resistance of small wire will heat the wire. Every coil has a resistance of 40 ohm; a smaller gauge wire would restrict this resistance. While designing a generator according to the application, which it will be used for, need to be stored in mind. The query should be answered, which property, the current or the voltage, is of greater importance? The hassle that is produced by means of a giant coil is the field density is reduced over the thickness of the coil. The thickness of the coil reduces the magnitude of the flux. In our layout we place the coils between two attracting magnets.

## 8. CONCLUSION

We can conclude that, the machine arrangement generates electrical energy without any friction with flywheel and it can be utilized in the maximum amount. We have successfully designed the project and applied on frame, the generated electricity is utilized to charge the cell phones and telephone devices; we also understood the concept of electromagnetism and how to generate electrical energy via capacity of simply putting the magnet and coil of equal quantity on distinctive disks besides making any contact. The voltage output taken from the assembly is absolutely dependent on the rpm of the wheels so voltage is fluctuating so a battery is used to supply a regular power supply to charging

vehicle or appliance. A battery linked to the generator assembly is continuously charged when shaft moves at 80- 90 rpm which is normal velocity of bike. By this assembly battery is continuously charging.

## 9. REFERENCES

1. Magnus Hedlund, Johan Lundin:- "Flywheel Energy Storage for Automotive Applications" by Energies 2015, 8, 10636-10663
2. Akhilesh Barwahe:-"Electricity Generation Using Flywheel"" Volume 4 Issue IV, April 2016 IC Value: 13.98 ISSN: 2321-9653
3. Jamie Patterson, 2004, Flywheel Energy Storage System, California Energy Commission Public Interest Energy Research Program
4. Michael Mathew , Design of flywheel for improved energy storage using computer aided analysis, Department of Mechanical Engineering National Institute of Technology Rourkela,769008 (2008-2009)
5. B.Sneha , Dr.M.Damodar Reddy, "Generation of Power from Bicycle Pedal", October 2015