

# Analysis for Optimum Design of Automotive Flywheel

Jayesh Sanjay Patil

*Mechanical Undergraduate, Akurdi- Chikhali Road, Chikhali, Pune, Maharashtra, India - 412114*

\*\*\*

**Abstract** - Flywheels are used for storing inertial energy in rotating machine engines and to limit speed fluctuations. In Dual Mass flywheel (DMF) the rotating mass is split into two and is joined by a damping mechanism. It is commonly in hardest use during engine start up and shut down. In flywheel design, important aspects to consider include geometry (cross-section), rotational velocity and material strength. Also, to consider is the mass moment of inertia which when too much the system will be sluggish and unresponsive whereas when too little the system would lose momentum over time. The material strength directly determines the energy level that can be produced safely when coupled with rotor speed. This together with rotational velocity result to the flywheel being very highly stressed hence necessary to determine stresses accurately using a discrete method as provided for by ANSYS software. During shaft rotation, centrifugal forces generate stresses in the circumferential as well as radial directions. This paper describes studies on the analysis of stresses, strains induced in the Flywheels, along with the deformation in the flywheels, with the help of Static structural and Modal analysis. Finally, a conclusion of the generated results specific which design of Flywheel is optimum.

**Key Words:** Flywheel, ANSYS, Dual Mass Flywheel (DMF),

## 1. INTRODUCTION

Flywheels are used in storage and release of energy in rotating machine engines known as inertial energy. It absorbs mechanical energy and serves as a reservoir, storing energy during the period when the supply of energy is more than the requirement and releases it during the period when the requirement of energy is more than the supply. They are basically meant to limit speed fluctuations through the amount of inertia contained i.e. the mass moment of inertia. In addition, it soothes out torsional excitation of crankshaft and avoids vibrations. This is majorly accomplished by a flywheel mass. In DMF, the mass is split into two that are torsional linked by elastic springs. Installation is by mounting a flywheel onto one of the axes of the machine, integral with one of the rotating shafts. Applications include- automobile engines, industrial

punch presses and other ICE's. In all cases their design is intended to be most economical. Examples are solid disk and composite flywheels. Focuses on exploring the effects of flywheel geometry on its energy storage/deliver capability per unit mass, further defined as Specific Energy. Proposed computer aided analysis and optimization procedure results show that smart design of flywheel geometry could both have a significant effect on the performance and as well as operational vibrations while engaging and reduce loads exerted on the shaft due to reduced mass at high rotational speeds. FE analysis is carried out for different geometry of the flywheel and maximum von Misses stresses and total deformations are determined.

## 2. PROBLEM DEFINITION

The paper deals with the study of stresses, elastic strains and deformations along various frequency modes induced in all 4 flywheels due to different parameters like rotational velocity with fixed center of rotation of Flywheel, Force along with the axis of rotation of the flywheel, material of flywheel, and outer diameter of flywheel. Through this study it is possible to find out the factors that contribute to increase in stresses on a flywheel. The main problem faced in such a study is that it is tedious to be done in a numerical background. To overcome this problem, modern technology was used. Using modern software like UG NX 12 and Ansys workbench, modeling and analysis were made easier and more accurate.

## 3. OBJECTIVES

Design and Analysis for obtaining felicitous Flywheel for an Automotive system using static structural force analysis, Static structural Rotational Velocity analysis and Modal analysis approach.

1. The Flywheel is to be rigid and stable.
2. Optimum Flywheel design.
3. Stress analysis, Elastic stain analysis.
4. Deformation analysis due to different frequency modes.

#### 4. DESIGN METHODOLOGY

Classification of Flywheel -

Based on the mode of operation, two kinds of flywheel designs are there:

- Disc type - Suited for smaller sized engines/machines
- Arm type - Suited for larger sized engines/machines

Application of flywheels

1. IC engine
2. Sheet metals press
3. Kinetic energy recovery system (KERS)

Fundamental Principles of Flywheel Design and Sizing Calculations

Firstly, calculate the mass moment of inertia required by the flywheel to smoothing out the fluctuation/variations of kinetic energy in the system. This will be discussed in this article.

Secondly, calculate the geometry/dimensions of the flywheel based on the calculated mass moment of inertia and material properties. This will be covered in another article.

#### Design steps and formulas

##### Step-1: Coefficient of fluctuation calculation

Input required: Maximum and minimum speed

Flywheel inertia/size depends upon the fluctuations in speed. The difference between maximum & minimum speeds during a cycle is called maximum fluctuation of speed.

The ratio between maximum fluctuations of speed to mean speed is called coefficient of fluctuation of speed ( $C_s$ ).

Consider,  $W_{max}$  = Max. Speed during the cycle

$W(\min)$  = Min. speed during the cycle

$$W(\text{mean}) = \text{Mean speed} = (W_{\max} + W_{\min}) / 2 \dots\dots \text{eq.1}$$

Therefore, Coefficient of Fluctuation of speed,

$$C_s = [2 * (W_{\max} - W_{\min})] / [W_{\max} + W_{\min}] \dots\dots \text{eq.2}$$

Note: The smaller the  $C_s$  value, larger the flywheel, but smoother the operation.

Step-2: Mass moment of inertia calculation

Input required: kinetic energy of the system

The general equation of kinetic energy for a flywheel system is given as,

$$K_e = 0.5 * I * (W_{\max}^2 - W_{\min}^2) \dots\dots\dots \text{eq.3}$$

Rewriting eq.3, we get

$$K_e = 0.5 I (W_{\max} + W_{\min}) (W_{\max} - W_{\min}) \dots\dots\dots \text{eq.4}$$

Substituting eq.1 & 2 in eq.4, we get

$$I = K_e / C_s W_{\text{mean}}^2 \dots\dots\dots \text{eq.5}$$

eq.5 is used to obtain necessary flywheel inertia corresponding to variations in speed.

We will try out a simplified problem on flywheel sizing and calculate the required moment of inertia.

#### Regarding units (Important):

1.  $K_e$  - N.m
2.  $W$  - rad/sec
3.  $I$  - Kg.m<sup>2</sup>

## 5. DESIGN PARAMETERS OF THE FLYWHEEL(S)

Standard parameters were considered while designing and performing the analysis. All 4 Flywheel that are analyzed have same properties.

1. Diameter of all 4 Flywheels are kept constant.
2. Material considered for all 4 Flywheels is Stainless steel and is kept constant throughout the analysis.

Stainless steel material is chosen for analysis because –

- a. Higher corrosion resistance
- b. Higher cryogenic toughness
- c. Higher work hardening rate
- d. Higher hot strength
- e. Higher ductility
- f. Higher strength and hardness
- g. A more attractive appearance
- h. Lower maintenance

Properties of the AISI type 304 Stainless-steel material are –

- a. Brinell Hardness – 123
  - b. Rockwell Hardness – 70
  - c. Ultimate tensile strength – 505 MPa
  - d. Yield Strength – 215 MPa
  - e. Modulus of elasticity – 190GPa to 200 GPa
  - f. Poisson’s ratio – 0.29
3. Rotational Velocity of the Flywheel, along the axis of the flywheel is 750 RPM.
  4. Force exerted on the Flywheel, along the axis of the Flywheel is 750 N.

## 5. ANALYSIS OF FLYWHEEL(S)

In order to find out the most optimum design for the flywheel, 4 major iterations were carried out and then the analysis was performed on them on ANSYS workbench. Furthermore, three major analysis criteria were considered –

- a. Static Structural Analysis using Force applied while engaging. The force of 750 N was kept constant for all 4 iterations throughout the analysis.

- b. Static Structural Analysis using Rotational Velocity, with the fixed center of rotation of the Flywheel, however, the rotational velocity of 750 RPM is kept constant for all 4 Flywheel iterations throughout the analysis.
- c. Finally, modal analysis is carried out and the vibrational frequencies of all 4 flywheels are found out up to 6 modes and at the same time their corresponding maximum deformation is found out for highest frequency mode.

### 5.1. Flywheel iteration Designs that are analyzed are shown below-

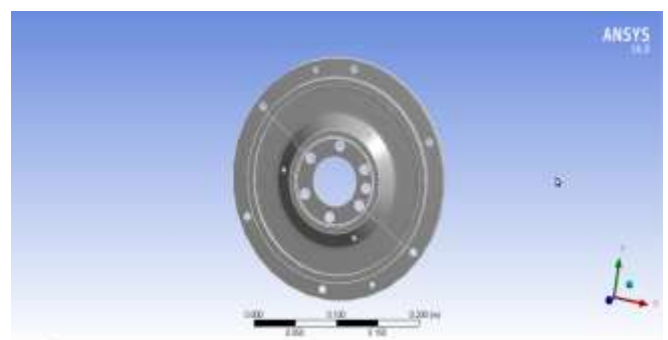

Fig -1: Flywheel iteration 1



Fig -2: Flywheel Iteration 2

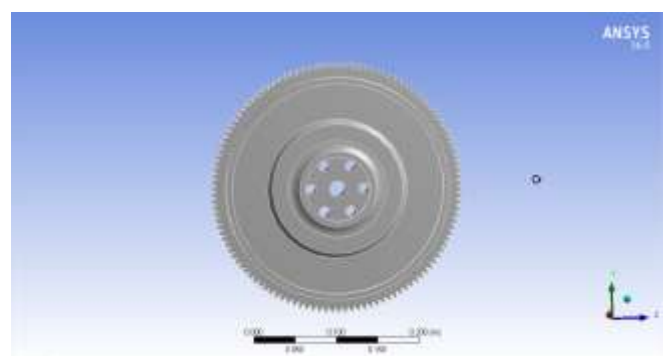

Fig -3: Flywheel iteration 3

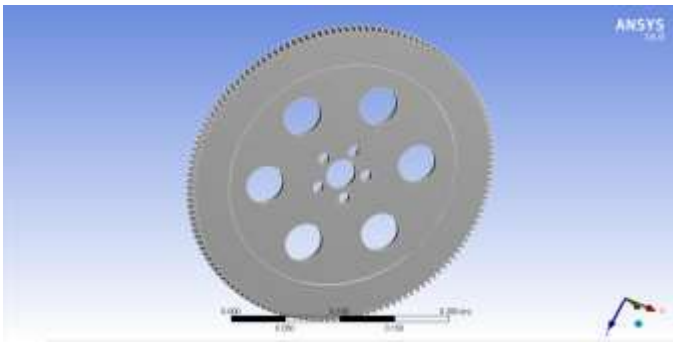

Fig -4: Flywheel iteration 4

The overall aim of a FEA is to recreate mathematical behavior of an actual engineering model of a physical prototype. This model is comprised of nodes, elements, material properties, real constants, boundary conditions and any other feature used to represent the physical system. Thus, analysis reflects the performance of a design to meet specifications as per its manufacturing and construction. Each node has 3-DOF, translations in the nodal x, y and z directions. In addition, it has mixed formulation capabilities for simulating deformations, plasticity, hyper elasticity, stress stiffening, large deflection and large strain capabilities.

### 5.2. Modeling Assumptions:

1. The material is isotropic.
2. Steady state conditions.
3. There is rigid connection on the drive shaft with no keyway for notch effects and no chamfering.

### 6.1. STATIC STRUCTURAL ANALYSIS USING FORCE

Static structure analysis is the most common application in FEM. Static analysis determines the displacement, stress, strain, force in structure or component caused by loads that do not induce inertia and damping effects. This project deals with the study of stress, deformation on rotor disc under static condition. After completion of finite element model, it must constrain and load must be applied to the model. User can define constrain and load in various way.

Firstly, Static structural analysis was performed, with force acting on the flywheels while engaging was considered. The force considered is 750 N as well as

the material which is Stainless steel (AISI Type 304) and is constant for the flywheel iterations.

The following figures show the results of static analysis with Force consideration.

The following results for each flywheel were found out-

- a. Total Deformation
- b. Directional Deformation
- c. Stress (von Mises)
- d. Elastic Strain

#### 1. Flywheel 1 -

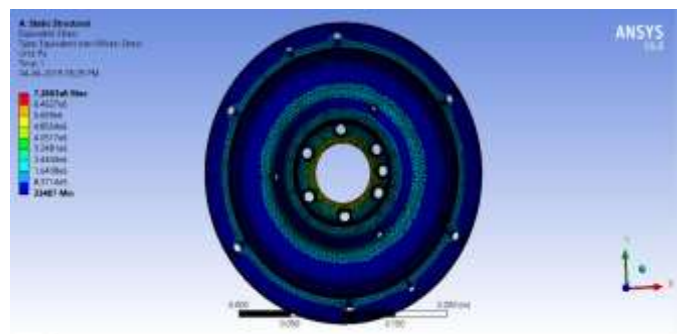

Fig -5: Total Deformation

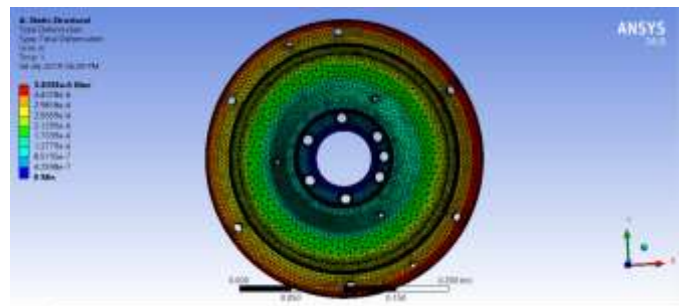

Fig -6: Equivalent Stress (von Mises)

#### 2. Flywheel 2 -

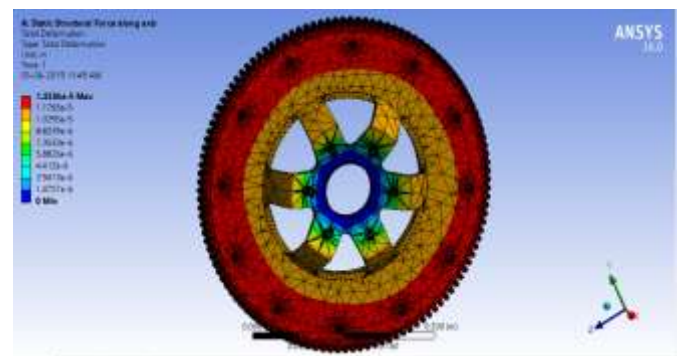

Fig -7: Total Deformation

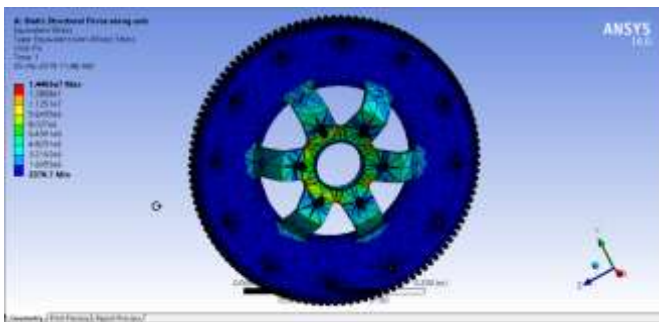

Fig -8: Equivalent Stress (von Misses)

3. Flywheel 3 -

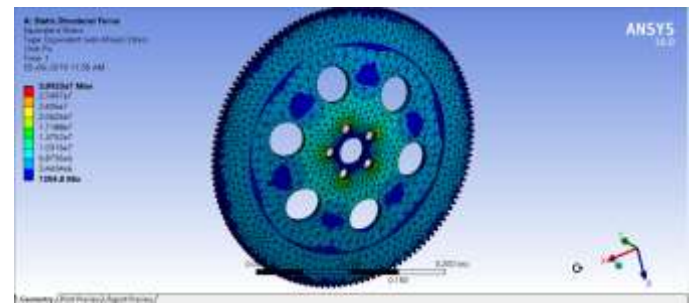

Fig -12: Equivalent Stress (von Misses)

Thus, the results obtained are then shown in the tabular format for easy comparison.

Table-1: Comparison of the results obtained due to Force applied on Flywheels along the Axis.

	Stress (von Misses) (in Pa)	Elastic Strain (von Misses) (m/m)	Total Deformation (in m)	Directional Deformation (in m)
Flywheel 1	7.2663e6	3.8195e-5	3.8338e-6	5.3853e-7
Flywheel 2	1.4465e7	7.5701e-5	1.3236e-5	1.323e-5
Flywheel 3	6.8668e6	3.558e-5	1.9127e-6	1.908e-6
Flywheel 4	3.0933e7	0.00016104	5.9851e-5	2.8367e-6

6.2. STATIC STRUCTURAL ANALYSIS USING ROTATIONAL VELOCITY

After completion of finite element model, it must constrain and load must be applied to the model. User can define constrain and load in various way.

Then, Static structural analysis was performed, with rotational velocity acting on the flywheels while engaging was considered. The rotational velocity considered is 750 RPM as well as the material which is Stainless steel (AISI Type 304) and is constant for the flywheel iterations and the center is kept fixed.

The following figures show the results of static analysis with Force consideration.

The following results for each flywheel were found out-

- Total Deformation
- Directional Deformation
- Stress (von Misses)
- Elastic Strain

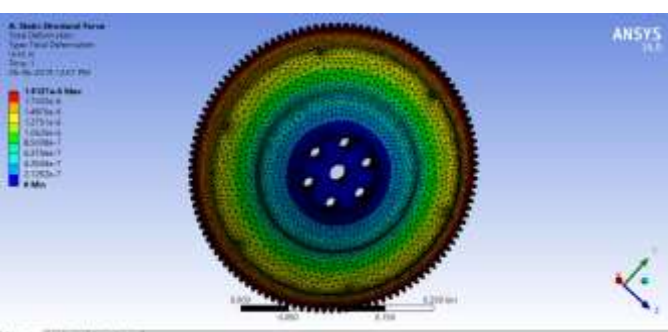

Fig -9: Total Deformation

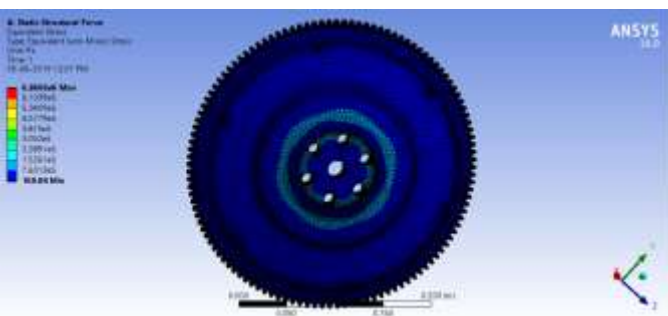

Fig -10: Equivalent Stress (von Misses)

4. Flywheel 4 -

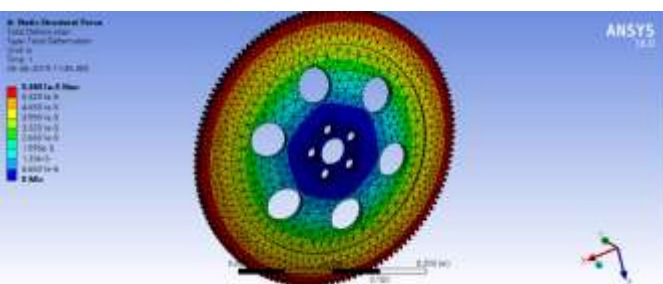

Fig -11: Total Deformation

### 1. Flywheel 1

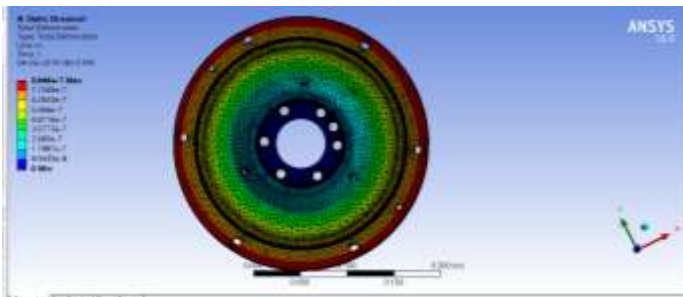

Fig -13: Total Deformation

### 3. Flywheel 3

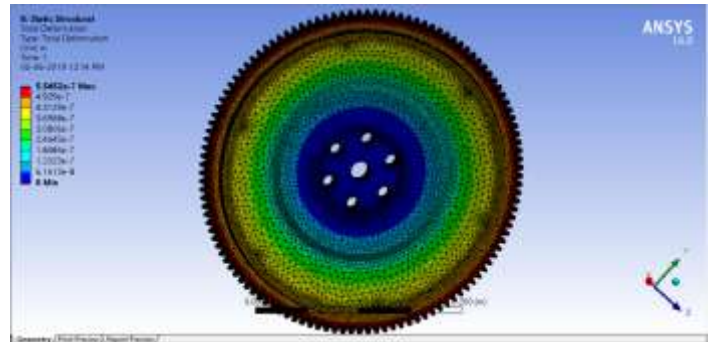

Fig -17: Total Deformation

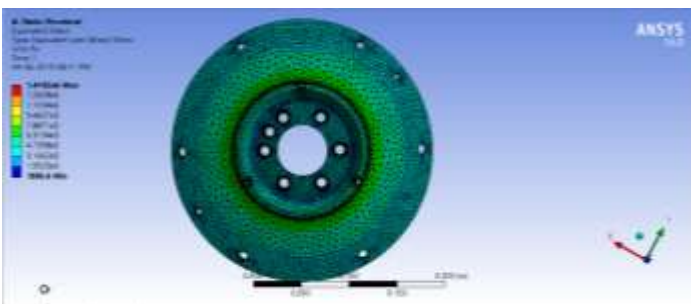

Fig -14: Equivalent Stress (von Mises)

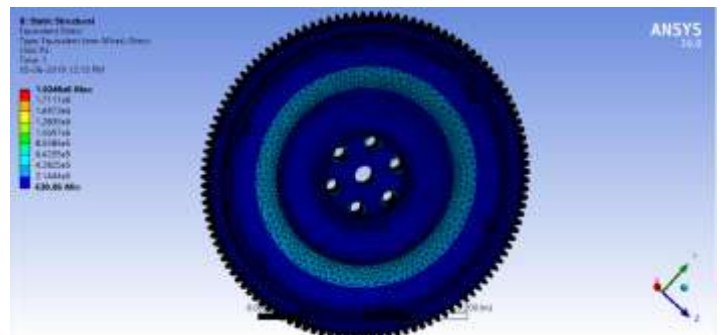

Fig -18: Equivalent Stress (von Mises)

### 2. Flywheel 2

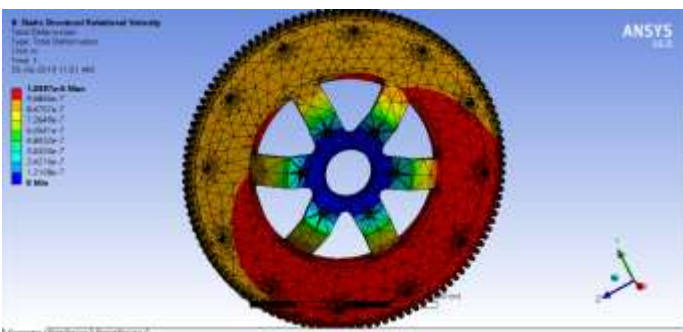

Fig -15: Total Deformation

### 4. Flywheel 4

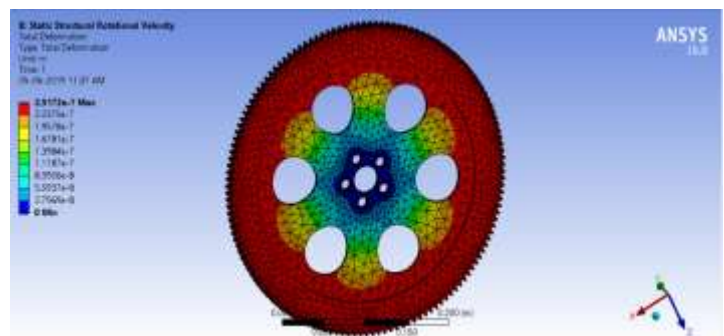

Fig -19: Total Deformation

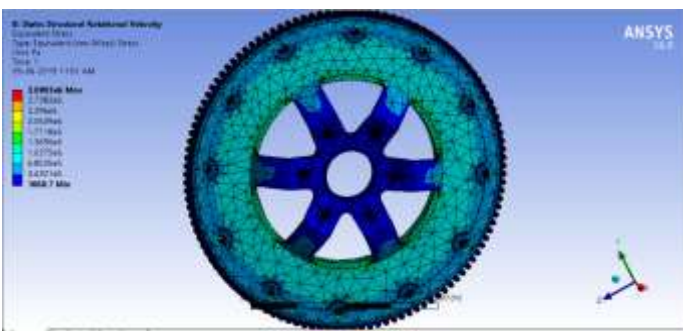

Fig -16: Equivalent Stress (von Mises)

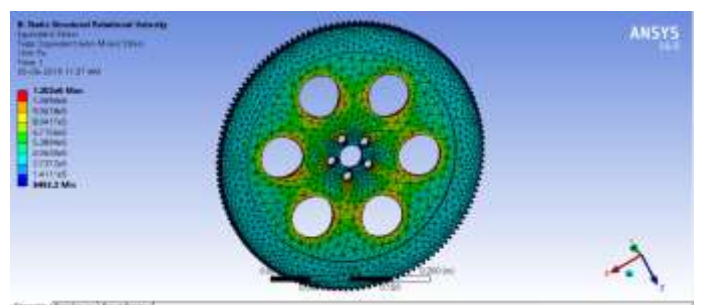

Fig -20: Equivalent Stress (von Mises)

**Table-2: Comparison of the results obtained due to Rotational velocity applied on Flywheels along the Axis.**

	Stress (von Misses) (in Pa)	Elastic Strain (von Misses) (m/m)	Total Deformation (in m)	Directional Deformation (in m)
Flywheel 1	1.4182e6	7.4296e-6	8.049e-7	2.7796e-7
Flywheel 2	3.0803e6	1.6197e-5	1.0897e-6	9.4946e-7
Flywheel 3	1.9249e6	9.9794e-6	5.5452e-7	6.0608e-9
Flywheel 4	1.202e6	6.2308e-6	2.5172e-7	2.4406e-7

**6.3. MODAL ANALYSIS**

Lastly, by performing modal analysis, frequency modes of vibrations were found out for each individual flywheel. The total of 6 modes were calculated and the deformation for all the individual modes was also found.

The 6 frequency modes are each flywheel is tabulated in the tabular format below.

**Table-3: Modal Analysis with Frequency modes**

Frequency Modes (Hz)	Flywheel 1	Flywheel 2	Flywheel 3	Flywheel 4
MODE 1	589.75	158.78	1158.1	235.62
MODE 2	597.68	158.8	1158.1	235.65
MODE 3	1389.1	432.89	1288.8	290.28
MODE 4	1486.4	506.37	1445.7	456.42
MODE 5	1551.9	790.47	1445.7	456.46
MODE 6	3546.9	791.66	2550.8	1118.4

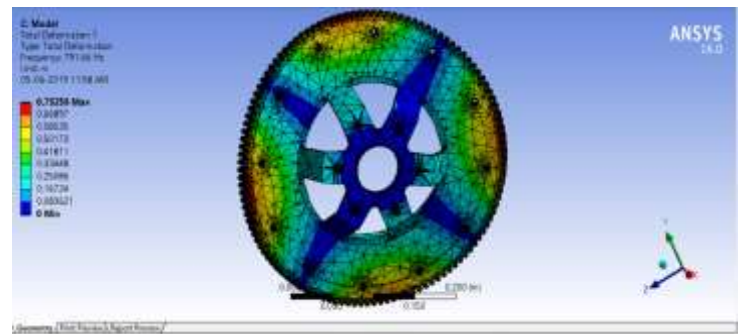

**Fig -22: Flywheel iteration 2 – Modal Frequency 6 – Total Deformation**

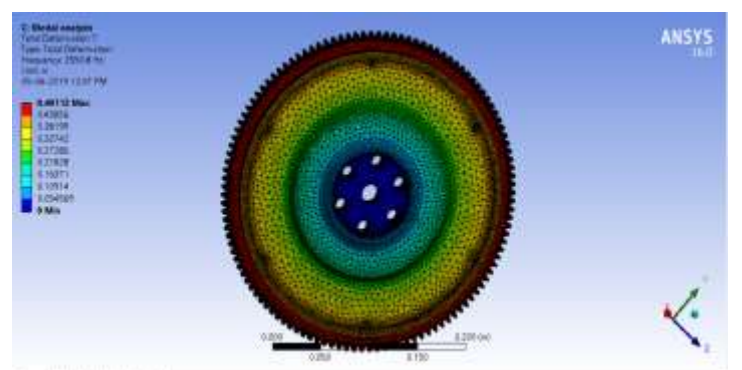

**Fig -23: Flywheel iteration 3 – Modal Frequency 6 – Total Deformation**

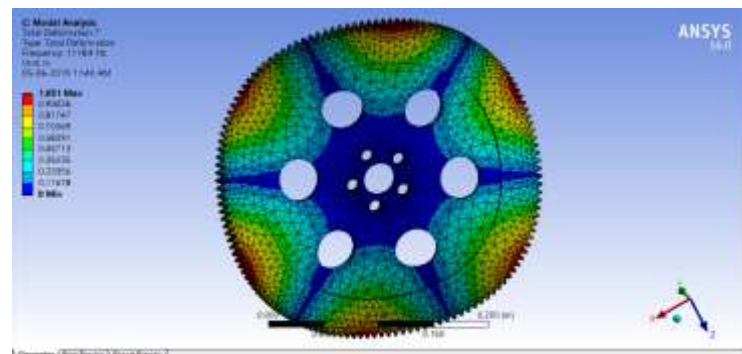

**Fig -24: Flywheel iteration 4 – Modal Frequency 6 – Total Deformation**

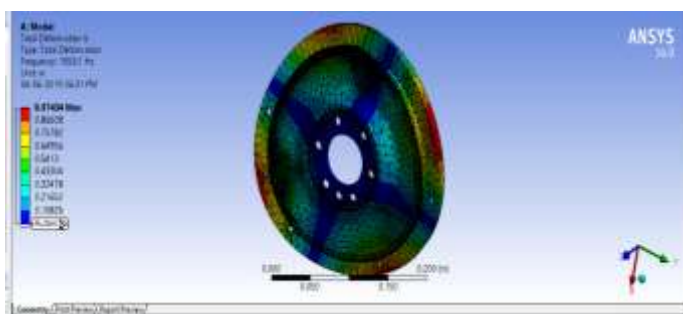

**Fig -21: Flywheel iteration 1 – Modal Frequency 6 – Total Deformation**

Furthermore, to avoid excess readings obtained and complexity, only the highest frequency modes and its corresponding total deformation is found out. These results are therefore further organized in tabular format below.

It is found that, for some parameters, Flywheel iteration 2 resulted in less frequency mode of vibration with 791.66 Hz and its corresponding Total deformation was 0.75457 m which is considerably less when compared to other flywheel iterations.

**Table-4: Maximum Deformation corresponding to Mode 6 Frequency**

	Flywheel 1	Flywheel 2	Flywheel 3	Flywheel 4
Mode 6 Frequency (Hz)	3546.9	791.66	2550.8	1118.4
Maximum Deformation (in m)	1.1709	0.75457	0.84539	1.0119

### CONCLUSION

The following conclusions were obtained from the experiment.

1. The stress value gets affected for different iterations of the Flywheels by keeping the rotational velocity of the flywheel constant. The stress value for Flywheel iteration 2 is considerably lower as compared to the other iterations of the Flywheels.
2. Similarly, the stress value obtained by the application of the force along the axis of the Flywheels differs from one another for same force value. It is found that Flywheel iteration 2 was considerably lower in the stress concentration when compared to the other iterations.
3. The vibrational frequencies for all 4 Flywheels were found out by performing Modal analysis, it can be observed that the vibrations in Flywheel iteration 2 is quite (in Hz) as compared to the other iterations.
4. The deformation for the highest frequency mode i.e. mode 6 is lowest in Flywheel iteration 2, hence, it is quite stable and in therefore will remain rigid and intact at higher speeds.
5. There is a possible presence of a critical speed value below which the effect of density of material gets negligibly low. Increase in diameter tends to promote more stress induction but this effect gets nullified when the flywheel is balanced.
6. Outer diameter of flywheel and speed of rotation together facilitates the drastic increase in stress values. Flywheel with higher outer diameter and higher speed has more stress induced. Keeping any one of them ensures more protection against failures.

### REFERENCES

- [1] Kobia K. Lawrence and Mao Ya, "Finite element analysis of radial stress distribution on axisymmetric variable thickness Dual Mass Flywheel using ANSYS.", *Innovative Systems Design and Engineering*, Vol.5, No.4, 2014.
- [2] ASM Material Data Sheet, June 08 2019, retrieved from <http://asm.matweb.com/search/SpecificMaterial.asp?bassnum=mq304a>
- [3] ITony. A. Baby, IITony Kurian, IIMelvin Eldho Shibu, "Stress Analysis on Flywheel", *International Journal of Advanced Research in Education & Technology (IJARET)*, Vol. 2, Issue 3 (July - Sept. 2015).
- [4] Erasaslan A.N, Yusuf O, 2004. A Parametric Analysis of Rotating variable thickness elastoplastic annular disc subjected to pressurized and radially constrained boundary conditions. *Engineering, Env. Science*, pp. 381-395.
- [5] Ganesh B.K, Srithar K, 2010. *Design of Machine Elements*, 2nd Edition. New York: McGraw.
- [6] J Carvill, 2003. *Mechanical Engineer's Data handbook*. s.l.:BH publishers Elsevier science.
- [7] J.N Sharma, Dinkar Sharma, Sheo Kumar, 2012. Stress and strain analysis of Rotating FGM thermoelastic circular disc by using FEM. *International Journal of pure and applied mathematics*, pp. 339-352.