

AUTOMATIC HIGHWAY LIGHTING SYSTEM

Dr. M.K. Bhasakar¹, Lalit Tak², Paras Jain³, Kritika Kulshrestha⁴, Preeti Chauhan⁵,
Nitin Kumar Meena⁶

¹Professor, Dept. of Electrical Engineering, MBM Engineering College, Jodhpur, Rajasthan, India

^{2,3,4,5,6}Students of B.E. Electrical Engineering, MBM Engineering College, Jodhpur Rajasthan, India

Abstract – One of the biggest motivators people have for conserving electricity in their homes is the accumulated savings in their energy bills at the end of the year. There are other reasons why conserving electricity is important beyond the impact on your wallet. Electricity can be obtained from solar or wind power, but most electricity used in homes comes from the burning of fossil fuels such as oil or coal. These fuels are needed to power the turbines that produce electricity. These resources are not unlimited or renewable; the faster they are used and the more electricity that is consumed, the quicker they will be depleted. The project is designed to detect vehicle movement on highways to switch ON only a block of highway lights ahead of the vehicle, and to switch OFF the lights behind the vehicles to save energy. During night all the lights on the highway remain ON for the vehicles, but lots of energy is wasted when there is no vehicle is movement. This proposed system provides a solution for energy saving. This is achieved by sensing an approaching vehicle and switches ON a block of highway lights ahead of the vehicle. As the vehicle passes, the lights behind the vehicle switch OFF automatically. So when there are no vehicles on the highway, then all the lights remain OFF. Sensors used on either sides of the road send logic commands to microcontroller to switch ON/OFF the LEDs. Intensity control is also possible by Pulse Width Modulation (PWM) generated by the microcontroller. Thus this way of dynamically changing intensity ON/OFF helps in saving a lot of energy.

Key Words: Microcontroller, IR Sensor, Highway Light, Led, Potential divider.

1. Introduction

Generally, highway lights are switched on for whole night and during the day, they are switched off. But during the night time, highway lights are not necessary if there is no traffic. Saving of this energy is very important factor these days as energy resources are getting reduced day by day. Alternatives for natural resources are very less and our next generations may

face lot of problems because of lack of these natural resources. Highway lighting provides a safe night time environment for all road users including pedestrians. Providing highway lighting is one of the most important and expensive responsibilities of a city. Lighting can account for 10–38% of the total energy bill in typical cities worldwide. Highway lighting is a particularly critical concern for public authorities in developing countries because of its strategic importance for economic and social stability. Inefficient lighting wastes significant financial resources every year, and poor lighting creates unsafe conditions. Energy efficient technologies and design mechanism can reduce cost of the highway lighting drastically. The main objective of the project is to reduce the power consumption and efficient utilization of renewable sources for the application of highway lightening. Hence, this project is aimed at design and implementation of an automatic system to reduce energy consumption of highway lighting system up to the maximum possible extent. The availability of vehicle is sensed by using an array of Infrared Sensors (IR), which senses the traffic movement. LDR is used to detect the presence of day light. In this system, the highway lights are switched ON/OFF automatically during the presence of the traffics only during the nights.

1.1 Existing Systems

The existing systems consist of manual controls which need constant monitoring and maintenance. Considering the wastage of energy due to manual control many systems have been introduced. These systems are designed in such a manner that they could reduce their intensity and save as much energy as possible. Systems like these use LEDs (Light Emitting Diode) instead of HID (High Intensity Discharge) lamps due to dimming feature. There is a time slot allotted during which the intensity of the system keeps reducing and turns the lights OFF at morning. The time slot starts when it is specified. Reduction of intensity starts gradually at midnight when it is not much dark and there is not much traffic and is switched OFF at 6

in the morning. Some use IR (Infrared Ray) sensors to detect vehicles. Existing systems do overcome the drawbacks of HID based systems, but do not save enough energy as they are time based also in seasons like monsoon the environment remains dark compared to regular days. Winters bring the fog and if the lights are dim it could result into a great accident or disaster. Therefore still some improvements in systems like these are needed. Time slot based systems consider the time slot as an advantage, but it actually is a drawback as it could not work in all conditions.

2. Automatic Highway Lighting System

The main aim of this project is that it saves energy by putting on the lights of the system only when the system detects movement of vehicle. The system switches on the highway light ahead of the vehicle and switches off the trailing lights simultaneously. In order to detect movement of vehicles, sensors are used. The system automatically puts on the lights that are ahead of the vehicle detected and as soon as the vehicle moves ahead, the trailing lights are switched off. This is better than the existing system where the highway lights are kept on always unlike this system where the highway lights are put on only when movement of vehicle is detected which helps in saving lot of energy. During day time these lights are dim as this system has the capability to sense external lights. Thus this system senses the external light and then accordingly switches ON or OFF the highway lights. It uses PWM to control the intensity through microcontroller. The IR sensors sense the vehicle movements and send it to an Atmega family microcontroller that initiates commands for switching the lights ON/OFF.

Generally, street light controlling system is a simple concept which uses a transistor to turn ON in the night time and turn OFF during the day time. The entire process can be done by a using a sensor namely LDR (light dependent resistor). Nowadays conserving the energy is an essential part and day by day energy resources are getting decreased. So our next generations may face a lot of problems due to this lack of resources. This system doesn't need a manual operation to turn ON/OFF the highway lights. The highway light system detects whether there is need of light or not.

During the night time all the lights on the highway road remain on throughout the night, so the energy loss will be high when there is no movement of vehicles. This project gives a solution for saving the energy. This is

attained by detecting an approaching vehicle by turning ON the highway lights. As the vehicle passes away from the highway light, then the lights get turn OFF. If there are no vehicles on the road, then all the lights will turn OFF.

The infrared sensors are placed on each side of the road that are used to detect the vehicle movement and send the logic signals to a microcontroller to turn on/off the LEDs for a specific distance. Therefore, this way of dynamically switching ON and OFF the highway lights helps in reducing the power consumption.

The power supply of this project comprises of a step-down transformer, which steps down the voltage from 230v to 12V AC. This is transformed to a DC using a Bridge rectifier. A capacitor is used to remove the ripples using a capacitive filter, and it is then regulated to +5V from 12v using a 7805 IC voltage regulator, which is compulsory for the microcontroller as well as other components.

Furthermore, this project can be extended by using suitable sensors for detecting the street light failure, and then sending an SMS to the control department through a GSM modem for suitable action.

By using this project a lot of energy can be saved. The proposed system uses LEDs instead of other lamps. The project is especially designed for highway lighting in remote rural and urban areas where the traffic is low at times. The system is multipurpose, extendable and totally variable to user needs.

The applications of this highway light that glows on detecting vehicle movement mainly involve in highways, real time highway lights, hotels, parking areas and restaurants, etc. The advantages are; low cost, more life span and energy can be saved.

3. AUTOMATIC HIGHWAY LIGHTING SYSTEM CIRCUIT DESIGN

The system basically consists of an LDR, Infrared sensor, Power supply, relays and Microcontroller.

3.1 LDR

LDRs or Light Dependent Resistors are very useful especially in light/dark sensor circuits. Normally the resistance of an LDR is very high, sometimes as high as 1000000 ohms, but when they are illuminated with light resistance drops dramatically. Electronic opto sensors are the devices that alter their electrical

characteristics, in the presences of visible or invisible light. The best-known devices of this type are the light dependent resistor (LDR), the photo diode and the phototransistors. Light dependent resistor as the name suggests depends on light for the variation of resistance.

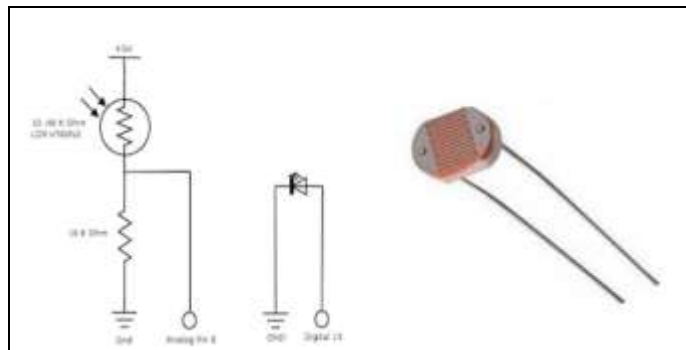

Fig - : 1 LDR circuit

3.2 Infrared Sensor

An infrared sensor is an electronic device that emits in order to sense some aspects of the surroundings. An IR sensor can measure the heat of an object as well as detects the motion as well as the presence of an object due to intervention or interruption. These type of sensors measure only infrared radiation, rather than emitting it that is called as a passive IR sensor. Usually in the infrared spectrum, all the objects radiate some form of thermal radiations. These types of radiations are invisible to our eyes that can be detected by an infrared sensor. The emitter is simply an IR LED (Light Emitting Diode) and the detector is simply an IR photodiode which is sensitive to IR light of the same wavelength as that emitted by the IR LED. When IR light falls on the photodiode, the resistances and these output voltages, change in proportion to the magnitude of the IR light received. An IR sensor is a device which detects IR radiation falling on it.

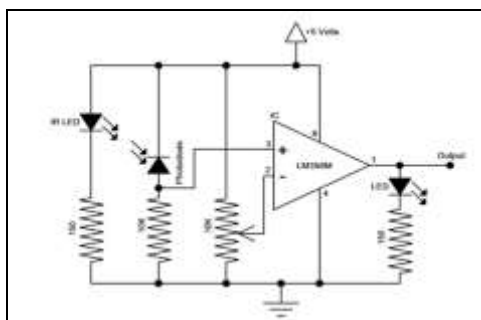

Fig - : 2 Circuit Diagram Of IR Sensor

3.3 Regulated Power Supply

Usually, we start with an unregulated power supply ranging from 9volt to 12volt DC. To make a 5volt power supply, IC 7805 voltage regulator as shown in figure has been used. The IC7805 is simple to use. Simply connect the positive lead form unregulated DC power supply (anything from 9VDC to 12VDC) to the input pin, connect the negative lead to the common pin and then turn on the power, a 5 volt supply from the output pin will be gotten.

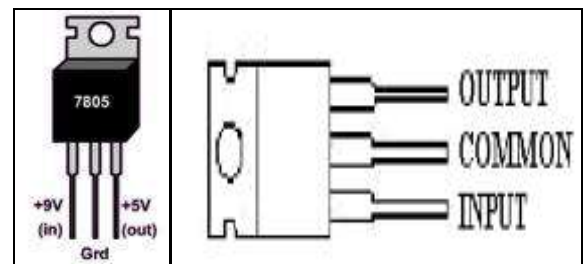

Fig - : 3 IC 7805 Voltage Regulator

3.4 Relays

A relay is usually an electromechanical device that is actuated by an electrical current. The current flowing in one circuit causes the opening or closing of another circuit. Relays are like remote control switches and are used in many applications because of their relative simplicity, long life, and proven high reliability. Relays are used in a wide variety of applications throughout industry, such as in telephone exchanges, digital computers and automation systems. Highly sophisticated relays are utilized to protect electric power systems against trouble and power blackouts as well as to regulate and control the generation and distribution of power. In the home, relays are used in refrigerators, washing machines and dishwashers, and heating and air-conditioning controls. Although relays are generally associated with electrical circuitry, there are many other types, such as pneumatic and hydraulic. Input may be electrical and output directly mechanical, or vice versa.

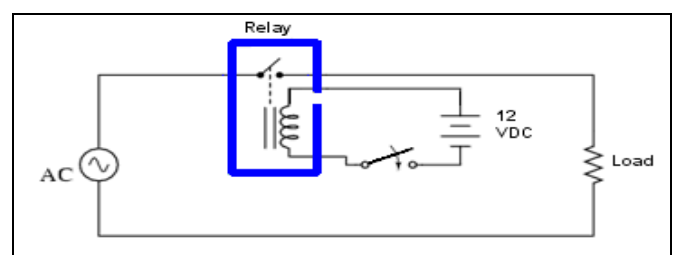

Fig - : 4 Circuit using a relay

3.5 Atmega328p Microcontroller

A microcontroller is a small computer on a single integrated circuit. In modern terminology, it is similar to, but less sophisticated than, a system on a chip (SoC); a SoC may include a microcontroller as one of its components. A microcontroller contains one or more CPUs (processor cores) along with memory and programmable input/output peripherals. Program memory in the form of ferroelectric RAM, NOR flash or OTP ROM is also often included on chip, as well as a small amount of RAM. Microcontrollers are designed for embedded applications, in contrast to the microprocessors used in personal computers or other general purpose applications consisting of various discrete chips. Microcontrollers are used in automatically controlled products and devices, such as automobile engine control systems, implantable medical devices, remote controls, office machines, appliances, power tools, toys and other embedded systems. This project mainly focuses on ATMEGA 328 microcontroller. Its pin diagram is shown in figure.

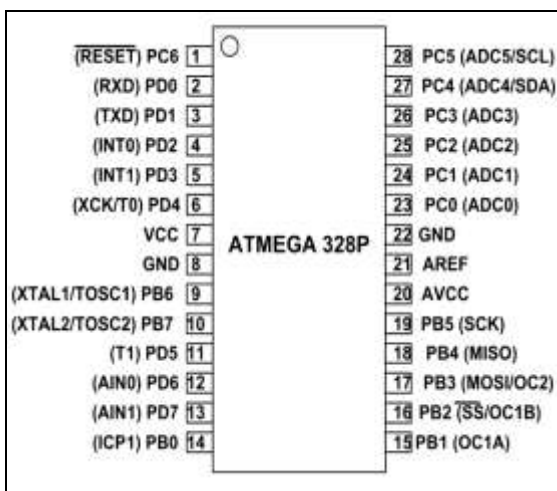

Fig - : 5 Atmega328p Microcontroller Pin Diagram.

4. AUTOMATIC HIGHWAY LIGHTING CONTROL CIRCUIT DESIGN

The highway model consists of 7 LEDs as highway lights and 8 pairs of photodiodes-IR diodes used as sensors, variable resistors and transistors which acts as switch as explained above. The IR diodes are placed on one side of the road and photodiodes are placed on the other side of the road, directly facing the IR diodes.

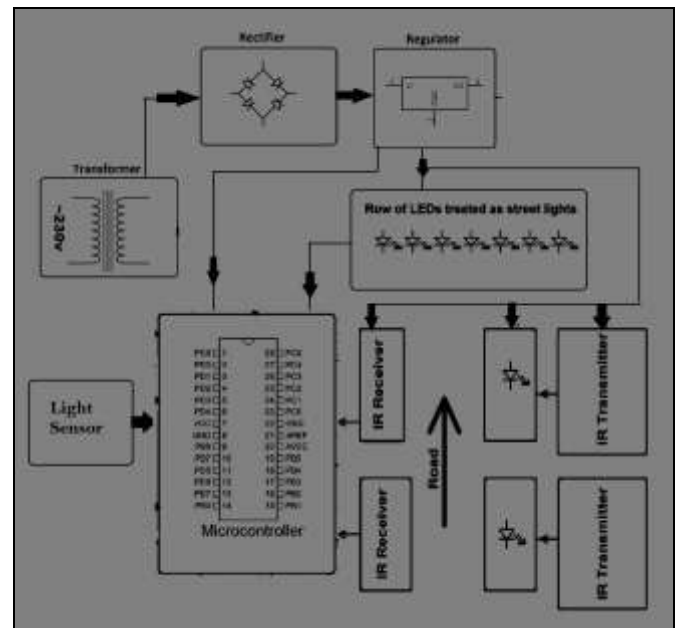

Fig - : 6 Block Diagram of The System

Consider the case when there is no vehicle on the highway. In this case, the IR radiation emitted from the IR diode directly falls on the photodiode which is exactly opposite to it. This causes the photodiode to fall in conduction state. This implies that photodiode conducts and current passes through it. The current passes through the photodiode and goes through the variable resistor and the base-emitter region of the transistor. This in turn connects the collector of the transistor to the emitter. From the circuit diagram we can see that emitter is connected to ground which implies that the collector also goes to the ground. The collector region of the transistor is connected to the port 1 (input port) which in turn goes to ground i.e., logic ZERO. So, to summarize we can say that, when there is no vehicle on the highway, then all the inputs to the microcontroller port 1 is ZERO.

Consider the case when a vehicle obstructs the IR radiation path. In this case, IR radiation is blocked and hence it does not fall on the photodiode. This in turn implies that photodiode doesn't conduct. Hence there is no current flowing through this first transistor. So, the collector is at HIGH state. Let us assume that the first Photodiode-IR diode pair IR path is obstructed. This leads to a transition from ZERO to HIGH at P1.0 pin.

The microcontroller is programmed in such a way that, whenever the pin P1.0 goes high, then a window of seven led lights ahead from the vehicle glows. In other words, the respective pins of port 2 and port 3 go

HIGH. This process goes on i.e., as the vehicle moves forward, the highway lights ahead of it glows and the trailing lights goes back to its original off state.

There are two basic modes of operation,

1. In the first mode of operation, initially when the vehicle is not sensed, all the streetlights will be in dim state. This is achieved by use of pulse width modulation technique through the program stored in the microcontroller. When a vehicle is not present on the highway, then the streetlights are made to glow for about 1ms and then for 100ms they are switched off. Thus, we get streetlights with less brightness. When a vehicle is sensed, all the streetlights are illuminated for 1ms and the window of streetlights are illuminated for 100ms. Thus we have a PWM wave of 99% duty cycle for those seven LEDs.

2. In the second mode of operation, when the vehicle is not present, all the streetlights will be in dark state. When a vehicle is sensed then the window of streetlights is illuminated in front of the vehicle.

5. Conclusions

This project of Automatic Highway Lighting System with Light Sensing is a cost effective, practical, ecofriendly and the safest way to save energy. It clearly tackles the two problems that world is facing today, saving of energy and also disposal of incandescent lamps, very efficiently. According to statistical data we can save more than 40 % of electrical energy that is now consumed by the highways. Initial cost and maintenance can be the draw backs of this project. With the advances in technology and good resource planning the cost of the project can be cut down and also with the use of good equipment the maintenance can also be reduced in terms of periodic checks. The LEDs have long life, emit cool light, don't have any toxic material and can be used for fast switching. For these reasons our project presents far more advantages which can over shadow the present limitations. Keeping in view the long term benefits and the initial cost would never be a problem as the investment return time is very less.

LDR sensor is the main conditions in working the circuit. If the conditions have been satisfied the circuit will do the desired work according to specific program. Each sensor controls the turning ON or OFF the lighting column. The lights has been successfully controlled by microcontroller. With commands from the controller the lights will be ON in the places of the movement

when it's dark. Finally this control circuit can be used in various purposes.

By using automatic highway light, one can save surplus amount of energy which is done by replacing sodium vapor lamps by LED and adding an additional feature for security purposes. It prevents unnecessary wastage of electricity, caused due to manual switching of streetlights when it's not required. It provides an efficient and smart automatic highway light control system with the help of IR sensors. It can reduce the energy consumption and maintains the cost. The system is versatile, extendable and totally adjustable to user needs.

6. Future Scopes

The above project we can develop solar street light system with Automatic highway light controller. The system can be powered from a battery, which can be charged during day time by harvesting the solar energy through a solar cell. The solar energy harvested from sunlight can be stored, inverted from DC voltages to AC voltage using sun tie converter. The AC voltage can be stepped down rectified and using the circuit. The above mentioned strategy will enable us to harvest solar energy in an effective way for the operation of the circuit and for powering the street light also.

6. Reference

- [1] Velaga, R. and Kumar, A. 2012. Techno-economic evaluation of the feasibility of a smart street system: A case study of rural India. *Procedia Social and Behavioral Sciences*. 62, 1220-1224
- [2] EchelonCorp. <https://www.echelon.com/applications/street-lighting/>
- [3] Bruno, A., Di Franco, F. and Rasconà, G. 2012. Smartstreet lighting. *EE Times*
- [4] The e-JIKEI Network Promotion Institute, et al. Smart street light system with communication means
- [5] "'Smart' streetlamps light up when you're near - CNN.com". *Edition.cnn.com*. Retrieved 24-12-2015
- [6] "The Smart Lighting Concept" (PDF). *Future Internet Lab Anhalt*. Retrieved 10-10-2017.
- [7] K.Y. Rajput, G. Khatav, M. Pujari, P. Yadav, Intelligent Street Lighting System Using Gsm,

International Journal of Engineering Science
Invention, Vol2, Issue 3, March 2013, PP. 60- 69.

- [8] D. A. Devi and A. Kumar, Design and Implementation of CPLD based Solar Power Saving System for Street Lights and Automatic Traffic Controller, International Journal of Scientific and Research Publications, Vol. 2, Issue 11, November 2012.
- [9] K. S. Sudhakar, A. A. Anil, K. C. Ashok and S. S. Bhaskar, Automatic Street Light Control System, International Journal of Emerging Technology and Advanced Engineering, Vol. 3, May 2013, PP. 188-189
- [10] White, Kent. "Brazing versus Soldering". TM Technologies, Tools & Methods for Better Metalworking. Archived from the original on 23 June 2017. Retrieved 2 May 2018.
- [11] Seher Yusnieva Kadirova, Daniel Ivanov Kajtsanov, A Real time street lighting control system, in "Microclimatic data collection multisensory system for design of energy model in residential buildings", Electrical Apparatus and Technologies (SIELA) 2018 20th International Symposium on, pp. 1-3, 2018.
- [12] Dhiraj Sunehra, Sangem Rajasri (2017) "Automatic street light control system using wireless sensor networks" have been discussed in area of power system.
- [13] Mustafa Saad, (October 2013) "Automatic Street Light Control System Using Microcontroller".