

Face Detection based on Image Processing using Raspberry Pi 4

Mr. Pranay Dattani

¹B.E Student, Electrical Engineering Department, Marwari Education Foundation Group of Institution, Rajkot, India

Abstract - Face recognition is a common part of a security system, and its useful to identify the face is a human or not. Image process is the base of any security system like fingerprint lock system, face lock system, eye detection. Face detection using raspberry pi 4 is faster image process and its proper identification of a face. The raspberry pi 4 is latest low-cost credit card size computer. In this paper face detection system for security purpose is based on open source computer vision (OpenCV) with the python programming. By using a different data base it's easy to train the trainer and detector. This concept is higher scope on security and automation systems.

Key Words: -Raspberry pi, OpenCV, haar cascade, cascade classifier, face detection, recognition.

1. INTRODUCTION

Face detection is a most successful and widely used security technique. The face detection security system is entirely based on image processing. Face recognize by the haar cascade. Haar cascade classifier is recognize human face and eyes of human face, the all are included in OpenCV. The cascade classifier checks the recognize face by a lips, eyes, and nose because this are common part of any human face. After this the haar cascade recognize face and compare with the stored data base. In the recognition process haar put a matrix on the face area like head, cheeks and it calculate the pixel. After the recognize the feature extraction and other steps are taken. Face recognition can be used as a key factor in crime detection mainly to identify criminals.

2. OpenCV

Open source computer vision (OpenCV) is a machine learning library. OpenCV has 2500 algorithms and more than that, the OpenCV use in face recognition, object detection, 3D point clouds. It has python, C, C++, java, android. It requires a small ram to process and its feature is very useful to face detection.

3. Cascade Classifier

The Cascade classifier is use to extract some feature. It has a haar classifier. The haar work on the pixel formation white and black pixel like:

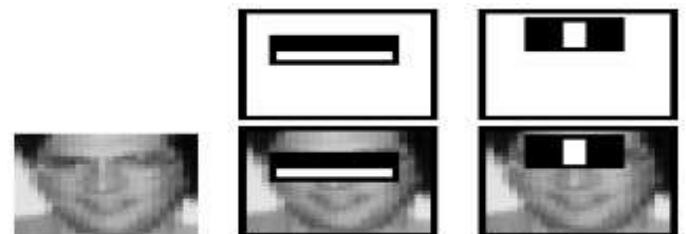

Fig1. Pixel calculation

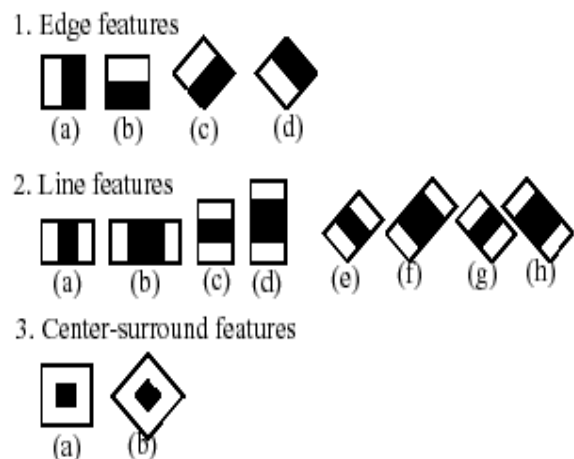

Fig2. Haar classifier

Any detect Image convert into a grey scale and then the Cascade classifier first check the detected face is a human or not, to check this its use a face cascade classifier(haarcascade_frontalface_default.xml), and eye cascade classifier(haarcascade_eye.xml) this file is help to check the human face or not. Its check the common are of human face like nose, eyes, lips. After this calculation the haar goes to the other area of face cheek and head area. Haar make a matrix to calculate the white and black pixel over there.

4. Raspberry pi

The Raspberry Pi 4 runs on forthcoming Debian 10 Buster.

- CPU – Broadcom BCM2711, Quad core Cortex-A72 (ARM v8) 64-bit SoC @ 1.5GHz.
- RAM – 1GB, 2GB or 4GB LPDDR4-2400 SDRAM (depending on model)
- WIFI – 2.4 GHz and 5.0 GHz IEEE 802.11ac wireless, Bluetooth 5.0, BLE.

- Ethernet – Gigabit.
- USB – 2 USB 3.0 ports; 2 USB 2.0 ports.

Face detection is identifying the human or not. The face comes in front of camera the camera captures the image and classifier take multiple gray image to train it and then the classify successfully train the face detection process work on the haar feature.

6. Methodology

This system categorized in different stages to capture, comparison, match. The raspberry pi board is connected with various accessories. It connects the SD card, keyboard, camera module, DC motor, and power supply.

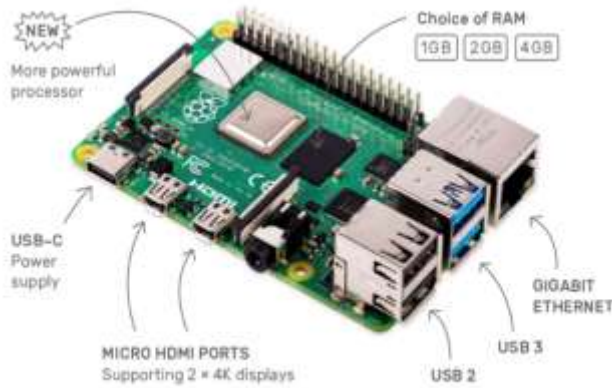

Fig3. Raspberry pi 4

5. Face detection

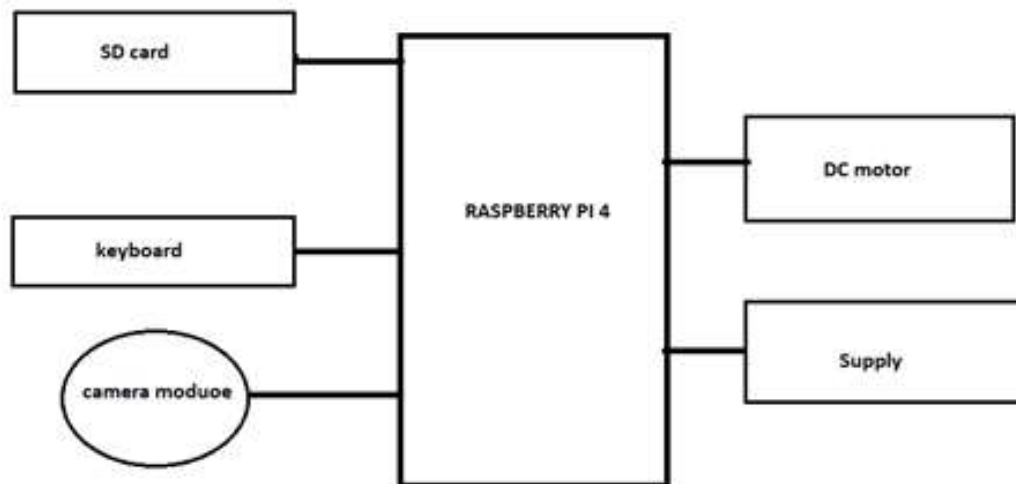

Fig4. Simple block diagram

6.1 SD card: - SD card is mounted on raspberry pi board to install the operating system. NOOBS operating system installs in raspberry pi. This SD card is class 10, its speed is high for run the process.

6.2 DC motor: - here servo motor use to open the door when face is recognized. Servo has a 3 wire, ground wire, supply wire, signal wire. In most of the case the brown wire is connected to the ground of the system. The red wire is connected with the +5V supply and last orange wire connect with PWM signal given to drive the motor.

6.3 Camera module: - face detection by use of the camera module. Its 5MP clearly visible picture quality camera module by invention by the raspberry pi foundation. It's easily affordable to any inventor for camera projects.

7. Software design

Write the code for the hardware it's required a Linux terminal. The capture image, its recognition and open the door all command written in the Linux terminal. Linux command is:

- **Sudo apt-get update** = to update the raspberry pi 4.
- **Cd /home/pi/Desktop** = To use the open file its located on the desktop.
- **Sudo apt-get install rpi.gpio** = To install a require library for the GPIO pin to configure the DC motor.
- **Nano face.py** = TO open the source code file.
- **Python face.py** = To run the source code.

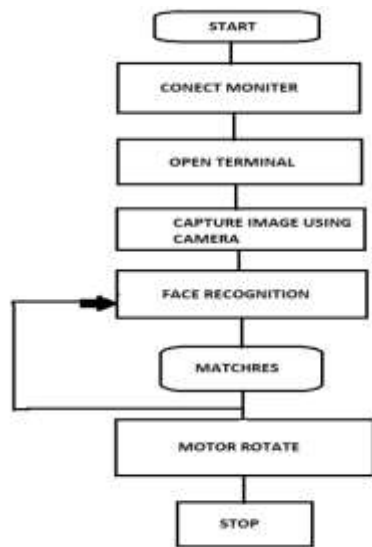

Fig5. Flow chart



Fig8. Project implementation

8. OUTPUT:-



Fig 6. Color into grayscale

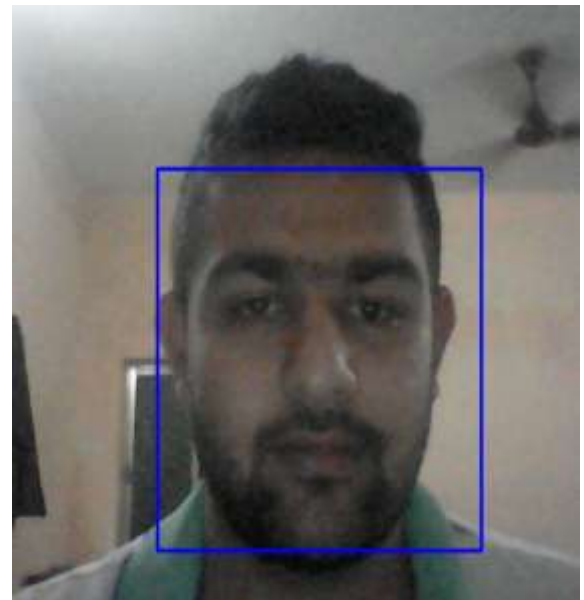

Fig9. Recognize face.

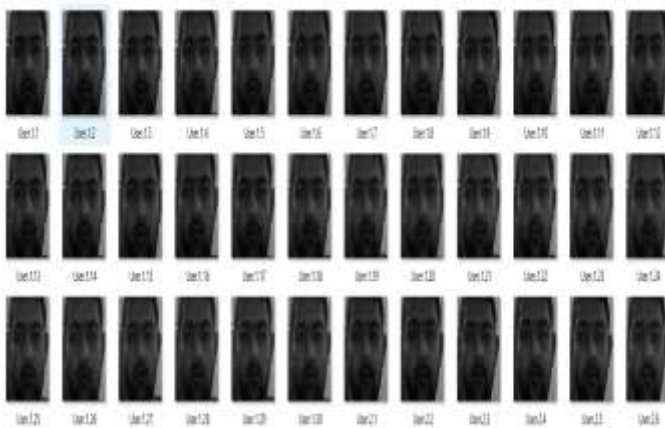

Fig7. Image store in data base of raspberry pi 4

9. CONCLUSION

The purpose of this system is to provide security for home. The recognition with the detection of the door lock system, it's entirely based on the face recognition. The purpose of the protect the house from the theft, by using this system we have batter security provide our house from the theft. By use the face recognition data base and face detection by the camera module, it's a real time face recognition system with smart door system. The all process is possible with the help of raspberry pi 4 and the OpenCV.

10. REFERENCES

[1] Harshal V. Khodaskar, Shashank Mane “Human Face Detection & Recognition Using Raspberry Pi” International Journal of Advanced Engineering, Management and Science ISSN: 2454-1311.

[2] Shrutika V. Deshmukh, Prof Dr. U. A. Kshirsagar “Face Detection and Face Recognition Using Raspberry Pi”, International Journal of Advanced Research in Computer and Communication Engineering, Vol. 6, Issue 4, April 2017

[3] Janhavi Katle, Sayali Pujari, Samrudhi Joshi, “Face Recognition In Non-Uniform Motion Using Raspberry Pi”, International Research Journal of Engineering and Technology, Volume: 03 Issue: 05 May-2016.

[4] Omkar Biradar, Anurag bhavne, “Face Recognition Based Attendance Monitoring System using Raspberry-pi and OpenCV”, International Research Journal of Engineering and Technology, Volume: 06 Issue: 01 Jan 2019.

BIOGRAPHIES



Mr. Pranay Dattani
Dept. of Electrical Engineering
Marwadi education foundation
Rajkot, Gujarat.