

# HYBRID RENEWABLE ENERGY SOURCES FOR POWER QUALITY IMPROVEMENT WITH INTELLIGENT CONTROLLER

J Mohammed siddi<sup>1</sup>, A. Senthil kumar<sup>2</sup>, S.Saravanan<sup>3</sup>, M. Swathisriranjani<sup>4</sup>

<sup>1</sup>PG Student, Department of EEE, Muthayammal Engineering College, Rasipuram, Tamilnadu, India.

<sup>2</sup>Assistant Professor, Department of EEE, Muthayammal Engineering College, Rasipuram, Tamilnadu, India

<sup>3</sup>Professor, Department of EEE, Muthayammal Engineering College, Rasipuram, Tamilnadu, India

<sup>4</sup>Assistant Professor, Department of EEE, Muthayammal Engineering College, Rasipuram Tamilnadu, India

\*\*\*

**Abstract:** Power Quality means to maintain purely sinusoidal current wave form in phase with a purely sinusoidal voltage wave form. Power quality improvement using traditional compensation methods include many disadvantages like electromagnetic interference, possible resonance, fixed compensation, bulkiness etc. So power system and power electronic engineers need to develop adjustable and dynamic solutions using custom power devices. These power conditioning equipments use static power electronic converters to improve the power quality of distribution system customers. The devices include Active Power Filter (APF), dynamic voltage restorer (DVR) and Unified Power Quality Conditioner (UPQC). APF is a compensator used to eliminate the disturbances in current. There are basically two types of APFs: the shunt type and the series type. This project examines the control of Shunt Active Power Filter (ES) based on electric springs (combination of L and C). Simulation results using MATLAB SIMULINK demonstrates the application of these methods to the control of APF.

**Keywords:** Active Power Filter (APF), Dynamic Voltage Restorer (DVR), Unified Power Quality Conditioner (UPQC), Shunt Active Power Filter (ES).

## 1. INTRODUCTION

With increasing penetration of intermittent and distributed renewable energy sources such as wind and solar power, there has been rising concern on power system stability. To address those issues, many demand-side management techniques have been proposed to ensure the balance between power generation and consumption. Such techniques include: i) scheduling of delay-tolerant power demand tasks; ii) use energy storage to compensate peak demand; iii) real-time pricing; iv) direct load control or on-off control of smart load. Energy storage is a valid solution to cope with the instantaneous balance between power supply and demand. However, costs and limited energy storage capacity of batteries are practical issues. Therefore, new solutions that can reduce energy storage are preferred. Electric Spring (ES) is a new smart grid technology that can provide electric active suspension functions for voltage and frequency stability in a distributed manner for future smart grid. Based on Hooke's law, ES has been practically realized with power electronic circuits for improving both voltage and frequency stability in micro-grid hardware simulator. The same functions for voltage and frequency stability have also been successfully evaluated in a simulation study for a medium sized power system comprising several power generators.

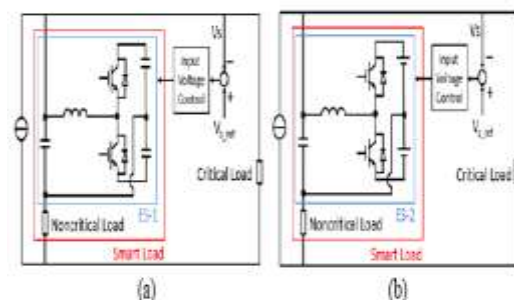

Fig.1 (a) ES version-1. (b) ES version-2.

Three versions of ES have been conceived as shown in figure.1. In the fundamental working principles and practical implementation of the first generation of ES (i.e. ES-1) with capacitive storage have been reported. By working under inductive and capacitive mode, ES-1 is capable of regulating the mains voltage to its nominal value in the presence of intermittent power injected into the power grid. With input voltage control, ES can work with non-critical loads that have high tolerance of voltage fluctuation.

Examples of the non-critical loads are thermal loads such as ice-thermal storage systems, electric water heater systems, air-conditioning systems and some public lighting systems. The first version of ES provides only reactive power compensation for mains voltage regulation and simultaneously varies the non-critical load power so as to achieve automatic power balancing within the power capability of the ES and its associated non-critical load.

The second version of ES (i.e. ES-2) by replacing capacitors with batteries on DC link. This arrangement allows ES-2 to work in eight different operating modes and to provide both active and reactive power compensation. It also enables ES-2 to perform extra tasks such as power factor correction and load compensation. The first and second versions of ES are illustrated in (a) and (b), respectively. Note that these two versions of ES are connected in series with their respective non-critical loads. The active suspension concept can also be incorporated into the input control of grid-connected bidirectional power converters for reducing voltage and frequency instability in the power grid. Such approach can be considered as the third version of ES (i.e. ES-3) that does not need a series non-critical load. The use of ES for reducing system instability and reducing energy storage requirement in power grid with substantial penetration of intermittent renewable power has been demonstrated previously.

The superior performance of ES over STATCOM in distributed voltage control has just been reported. ES is an emerging technology that deserves more investigations in order to explore its full application potential. This project focuses on its ability for reducing power imbalance in three-phase system. Power imbalance is a common and major power quality issue in a three-phase four-wire power system due to the load imbalance in the three phases. Unbalanced line current adversely affects key components in a power system and other equipment such as induction motors, power electronic converters and drives. Severe power imbalance leads to excessive neutral current, increased loss, and reduced power efficiency. Furthermore, the asymmetric voltage drop as a results of imbalanced line current could result in asymmetric voltages in the network, leading to deterioration of overall power quality. Conventional methods to address this issue (such as using three-phase to two-phase transformer, using rotating equipment to absorb negative sequence component, and using three-phase to single-phase rotary or static converter to feed single-phase load) are of low-efficiency and are costly. Modern power electronics technology has offered new solutions to tackle power system quality issues. For example, shunt active filter (AF) in the form of a current-based or voltage-based reactive power compensator has been proposed for reducing load imbalance. So, a mixture of methods can be used, including 1) using the shunt AF to redistribute real power among three-phase when the total amount of active power remains the same and 2) compensating positive, negative, and zero sequence component separately or jointly. Various techniques of using active power filters for improving power quality and reducing power imbalance can be founded.

In this project, a new three-phase ES topology is proposed and its operating principle is explained. This new circuit is based on the second version of ES. Besides its ability to enhance the power system stability, its extra use for reducing power imbalance in a three-phase power

system in a tall building will be demonstrated in a simulation study, with the support of experimental results obtained from a hardware prototype of the three-phase ES. The paper is an extension of a short conference paper previously presented. The essence of the incorporation of the ES into non-critical loads is to create a new form of smart or adaptive loads that can help stabilizing the power system as well as reducing power imbalance.

## 2. STRATEGIC MODELING

### a. Choke

In electronics, a choke is an inductor used to block higher-frequency alternating current (AC) in an electrical circuit, while passing lower-frequency or direct current (DC). A choke usually consists of a coil of insulated wire often wound on a magnetic core, although some consist of a donut-shaped "bead" of ferrite material strung on a wire. The choke's impedance increases with frequency. Its low electrical resistance passes both AC and DC with little power loss, but it can limit the amount of AC due to its reactance. The name comes from blocking "choking" high frequencies while passing low frequencies. It is a functional name; the name "choke" is used if an inductor is used for blocking or decoupling higher frequencies, but is simply called an "inductor" if used in electronic filters or tuned circuits. Inductors designed for use as chokes are usually distinguished by not having the low-loss construction (high Q factor) required in inductors used in tuned circuits and filtering applications.

### b. Linear & Non Linear loads

A linear circuit is an electronic circuit in which, for a sinusoidal input voltage of frequency  $f$ , any steady-state output of the circuit (the current through any component, or the voltage between any two points) is also sinusoidal with frequency  $f$ . Note that the output need not be in phase with the input. Informally, a linear circuit is one in which the values of the electronic components, the resistance, capacitance, inductance, gain, etc. don't change with the level of voltage or current in the circuit. Linear circuits are important because they can amplify and process electronic signals without distortion. An example of an electronic device that uses linear circuits is a sound system. A linear circuit is one that has no nonlinear electronic components in it. Examples of linear circuits are amplifiers, differentiators, and integrators, linear electronic filters, or any circuit composed exclusively of ideal resistors, capacitors, inductors, op-amps (in the "non-saturated" regime), and other "linear" elements. Some examples of nonlinear electronic components are: diodes, transistors, and iron core inductors and transformers when the core is saturated. Some examples of circuits that operate in a nonlinear way are mixers, modulators, rectifiers, radio receiver detectors and digital logic circuits

**c. Three Phase VI measurement**

The Three-Phase V-I Measurement block is used to measure three-phase voltages and currents in a circuit. When connected in series with three-phase elements, it returns the three phase-to-ground voltages and the three line currents. The block can output the voltages and currents in per unit (p.u.) values or in volts and amperes. If you choose to measure the voltages and currents in p.u., the Three-Phase V-I Measurement block does the following conversion as shown figure 2

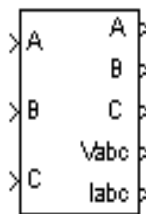

Fig.2.Measure 3-phase currents & voltages.

$$V_{abc}(p.u.) = \frac{V_{abc}(\text{volts})}{(V_{base} \cdot \sqrt{2} / \sqrt{3})} \tag{1}$$

$$I_{abc}(p.u.) = \frac{I_{abc}(\text{amperes})}{P_{base} / (V_{base} \cdot \sqrt{2} / \sqrt{3})} \tag{2}$$

**d. Bridge Amplifier**

It acts as a inverter .this block implement a bridge of selected power electronics devices. Series RC snubber circuits are connected in parallel with each switch device .the internal inductances Lon of diodes and thyristors should be set to 0 for most applications.A bridge-parallelamplifier configuration uses a combination of the bridged and paralleled amplifier configurations. This is more commonly used with IC power amplifiers where it is desired to have a system capable of generating large power into the rated load impedance (i.e., the load impedance used is the one specified for a single amplifier) without exceeding the power dissipation per amplifier. From the preceding sections, it can be seen that a bridged configuration doubles the dissipation in each amplifier while a paralleled configuration with two amplifiers halves the dissipation in each amplifier when operating into the rated load impedance. So when both configurations are combined, assuming two amplifiers per configuration, the resulting dissipation per amplifier now remains unchanged while operating into the rated load impedance, but with nearly four times the power that each amplifier is individually capable of, being delivered to the load.

**e. Hysteresis Control**

Hysteresis inverters are used in many low and medium voltage utility applications when the inverter line current is required to track a sinusoidal reference within a specified error margin. Line harmonic generation from those inverters depends principally on the particular switching pattern applied to the valves. The switching pattern of hysteresis inverters is produced through line current feedback and it is not pre-determined unlike the case, for instance, of Sinusoidal Pulse-Width Modulation (SPWM) where the inverter switching function is independent of the instantaneous line current and the inverter harmonics can be obtained from the switching function harmonics. This chapter derives closed-form analytical approximations of the harmonic output of single-phase half-bridge inverter employing fixed or variable band hysteresis current control. Through performing different simulations studies and comparing results obtained from the models to those computed from MATLAB/Simulink.

**f. Fixed-band Hysteresis Control**

For simplicity, we assume that the dc voltage supplied by the DG source is divided into two constant and balanced dc sources, as in the figure, each of value  $V_c$ . The  $RL$  element on the ac side represents the combined line and transformer inductance and losses. The ac source  $v_{sa}$  represents the system voltage seen at the inverter terminals. The inverter line current  $i_a$ , in Fig.4, tracks a sinusoidal reference  $i_a^* = \sqrt{2}I_a \sin(\omega_1 t + \phi)$  through the action of the relay band and the error current  $e_a(t) = i_a^* - i_a$ . When valve  $Q$  is turned on, the inverter voltage is  $v_a = V_c > v_a^*$ ; this forces the line current  $i_a$  to slope upward until the lower limit of the relay band is reached at  $e_a(t) = -\varepsilon$ . At that moment, the relay switches on  $Q$  and the inverter voltage becomes  $v_a = -V_c < v_a^*$ , forcing the line current to reverse downward until the upper limit of the relay band is reached as shown in fig.3

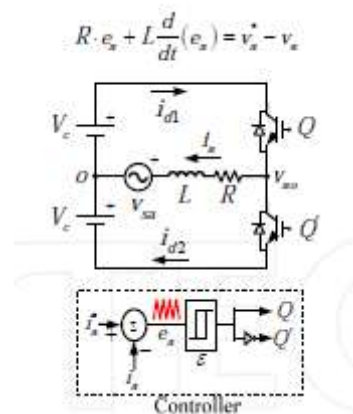

Fig.3. Single phase half-bridge inverter with hysteresis control

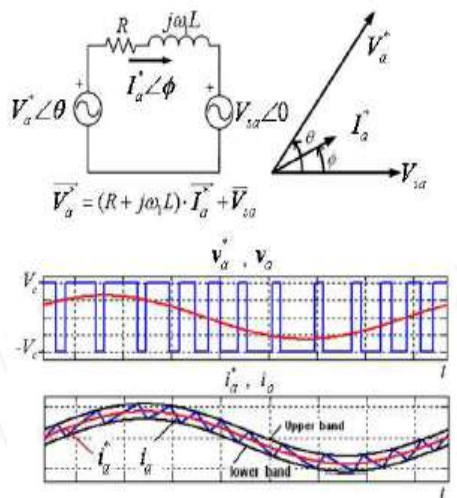

Fig.4. Reference voltage and the instantaneous outputs

**g. PQ Theory**

Power Quality is a set of electrical boundaries that allows a piece of equipment to function in its intended manner without significant loss of performance or life expectancy. The three phase power generated at the generating station is purely sinusoidal in nature. Wide spread application of static power electronics converters, zero and negative sequence components originated by the use of single phase and unbalanced loads, reactive power, voltage sag, voltage swell, flicker, voltage interruption etc. results voltage and current harmonics. The harmonics presence in the power lines results in varied problems, like, greater power losses in distribution; problems of electromagnetic interference in communication systems; and operation failures of protection devices, electronic equipments and, industrial processes.

Due to these problems, the quality of the electrical energy delivered to the end consumers is, more than ever, an object of great concern. The passive filters have been used as a conventional solution to solve harmonic currents problems, but they have disadvantages like electromagnetic interference, possible resonance, fixed compensation, bulkiness etc. To cope with these disadvantages, Operation of Three Phase Shunt Active Power Filter recent efforts have been concentrated on the development of Active Power Filters (APF). This paper analyzes the compensation strategy of Shunt Active Power Filter (ES) in two ways, Synchronous Detection Method (SDM) and digital control based on instantaneous power theory (p-q theory).

The control strategies of ES system are detailed in the second part of this paper. Simulation results in the third part demonstrate a comparative study between the two methods and show the advantages of digital control over SDM. As electrical power and electronic technology

develops, harmonic and reactive power in the power grid becomes increasingly serious. They have caused substantial hazards to safe and economic operation of power grid. Elimination of harmonic contamination in power grid and improving quality of electrical power supply to users has become one of the important research subjects on modern electrical power system.

Active filter can implement simultaneous tracking and compensation of varying harmonic and reactive power. Feature of compensation is less influenced by power grid reactance and frequency variation. Control circuit is easy to implement current-limiting protection so as to improve system safety. Hence, it is highly focused. As transient reactive power principle based active power filter is less influenced by power frequency variation, electrical circuit is simple with short delay and live features, and it is one of most widely applied methods of active filter compensation. However, as such harmonic testing method, based on principle of transient and reactive power, is complicated in filter control algorithm and phase is delayed due to incomplete elimination of reactive power component, it can be hardly applied to defects like voltage distortion or asymmetrical load.

This article addresses an active power filter which is based on improved, generalized and transient reactive power principle. Such active filter has simple control which can efficiently filter out reactive power component of the system. It can be adopted for 3-phase and 3-wire system and 3-phase and 4-wire systems. In addition, it also offers arbitrary adjustment to power factor of active power filter so that an active power filter with SVG function (static reactive generator). Theoretical analysis and conducted emulation indicate that the active power filter that is addressed in this article based on improved, generalized and transient reactive power principle is not only simple and reliable, but also it offers static and dynamic compensation.

**h. Active Power Filter (APF)**

The term active filter is a generic one and is applied to a group of power-electronic circuits incorporating power switching devices and passive energy-storage-circuit elements, such as inductors and capacitors. The functions of these circuits vary depending on the applications. They are generally used for controlling current harmonics in supply networks at the low- to medium-voltage distribution level or for reactive power and/or voltage control at high-voltage- distribution level. These functions may be combined in a single circuit or in separate active filters.

**i. Compensation of Current Harmonics**

Compensation of current harmonics is very important in low and medium-power applications and is covered by many publications. As mentioned above, the compensation of current harmonics reduces to a great extent the amount

of distortion in the voltage at the point of common coupling. The magnitude of the current and its waveform determine many of the power-system-design criteria. It is always recommended that the RMS value of the total current be reduced as much as possible (to reduce cable and feeder losses), which implies the reduction in current harmonics. This is because the total RMS value of the nonlinear load current is equal to the sum of the squares of the RMS values of each of the individual harmonics. The imposition of harmonics standards will soon oblige factories and establishments to control the amount of harmonics they inject into the power system.

#### j. Power Factor

The power factor of an AC electric power system is defined as the ratio of the real power flowing to the load to the apparent power in the circuit, and is a dimensionless number between 0 and 1 (frequently expressed as a percentage, e.g. 0.5 pf = 50% pf). Real power is the capacity of the circuit for performing work in a particular time. Apparent power is the product of the current and voltage of the circuit. Due to energy stored in the load and returned to the source, or due to a non-linear load that distorts the wave shape of the current drawn from the source, the apparent power will be greater than the real power. In an electric power system, a load with a low power factor draws more current than a load with a high power factor for the same amount of useful power transferred. The higher currents increase the energy lost in the distribution system, and require larger wires and other equipment.

Because of the costs of larger equipment and wasted energy, electrical utilities will usually charge a higher cost to industrial or commercial customers where there is a low power factor. Linear loads with low power factor (such as induction motors) can be corrected with a passive network of capacitors or inductors. Non-linear loads, such as rectifiers, distort the current drawn from the system. In such cases, active or passive power factor correction may be used to counteract the distortion and raise the power factor.

The devices for correction of the power factor may be at a central substation, spread out over a distribution system, or built into power consuming equipment. Power factor is a measure of how efficiently, or inefficiently, that electrical power is used by a customer. For industrial customers, a low power factor is generally caused by inductive loads such as transformers, electric motors and high-intensity discharge lighting. Customers that do not use electrical power efficiently are being charged additional fees for the inefficient use of power by their electric utility company. An electric utility's power load on an electrical distribution system fall into one of three categories; resistive, inductive or capacitive. In most industrial facilities, the most common power usages are "inductive." Examples of inductive loads include transformers, fluorescent lighting and AC induction motors. Most inductive loads use a conductive coil winding

to produce an electromagnetic field which permits the motor to function.

#### k. Measuring Power Factor

Power factor in a single-phase circuit (or balanced three-phase circuit) can be measured with the wattmeter-ammeter-voltmeter method, where the power in watts is divided by the product of measured voltage and current. The power factor of a balanced poly phase circuit is the same as that of any phase. The power factor of an unbalanced poly phase circuit is not uniquely defined. A direct reading power factor meter can be made with a moving coil meter of the electro-dynamics type, carrying two perpendicular coils on the moving part of the instrument. The field of the instrument is energized by the circuit current flow. The two moving coils, A and B, are connected in parallel with the circuit load. One coil, A, will be connected through a resistor and the second coil, B, through an inductor, so that the current in coil B is delayed with respect to current in A. At unity power factor, the current in A is in phase with the circuit current, and coil A provides maximum torque, driving the instrument pointer toward the 1.0 mark on the scale. At zero power factors, the current in coil B is in phase with circuit current, and coil B provides torque to drive the pointer towards 0. At intermediate values of power factor, the torques provided by the two coils adds and the pointer takes up intermediate positions. Digital instruments can be made that either directly measure the time lag between voltage and current waveforms and so calculate the power factor, or by measuring both true and apparent power in the circuit and calculating the quotient. The first method is only accurate if voltage and current are sinusoidal; loads such as rectifiers distort the waveforms from the sinusoidal shape.

## 2. OPERATIONAL ANALYSIS

The proposed electric spring is connected in series with the non-critical loads to form a new generation of smart loads as shown in Fig.5. A control scheme of such smart loads to reduce power imbalance. Thus confirmed the effectiveness of the new three phase electric springs in reducing power imbalance and voltage fluctuation along with hysteresis control.

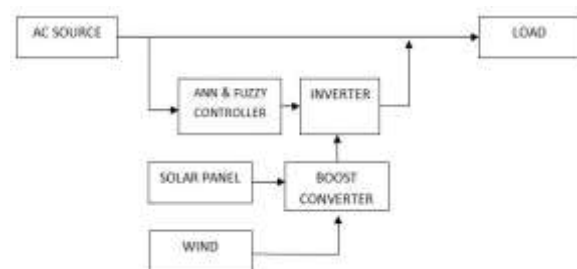

Fig.5. Block diagram for proposed system

### a. Source

It is a three phase source in series with RL branch of resistance 0.001 ohms and inductance 1e-8, a neutral current is connected to it along with ideal current measurement and Phase to phase rms voltage is 400V.

### b. Choke

A choke is an inductor used to block higher-frequency alternating current (AC) in an electrical circuit, while passing lower-frequency or direct current (DC). The choke's impedance increases with frequency. Its low electrical resistance passes both AC and DC with little power loss, but it can limit the amount of AC due to its reactance. The value of Resistance 0.01 ohms and inductance 1e-6 H.

### c. Load

There are three different types of nonlinear loads were used which are in parallel connections

- Resistor (3ohms) and diode.
- Resistor (4ohms), capacitor (50e-6F) and diode.
- Resistor (4ohms), inductor (1e-3H) and diode.

### d. Breaker

It acts as a switch and connects electric springs in series with three phase nonlinear loads. The transaction time at which the electric spring is connected with the load is about 0.05 sec.

### e. PI Controller

The current from the series connected DC capacitor is given to the different adders which are provided with positive and negative from the universal bridge as another input. then they are processed to get Vdc1 and Vdc2. Proportional integral controller is a control loop feedback mechanism. Vdc1 Vdc2 are subtracted from 1200 and the obtained output is given to discrete PI controller.

### f. Hysteresis Controller

The output of ICabc from PQ and I compensation is given as input to Iref and Iabc from V-I measurement is given as input to the I meas of hysteresis controller then they are demultiplexed and given to fuzzy. The output of fuzzy with and without NOT is multiplexed to get gate pulse g which is given to the universal bridge.

### g. Universal Bridge

It acts as an inverter .this block implement a bridge of selected power electronics devices. Series RC snubber circuits are connected in parallel with each switch device .the internal inductances Lon of diodes and thyristors should be set to 0 for most applications. the number of

bridge consists of three arms, snubber resistance and capacitance are 10000 ohms and in f F respectively .The power electronics device used is IGBT/diode where Ron is 1e^-4 .The output is given to the coupling inductor. The outputs are connected to the breaker.

Same pulses are needed to be applied for both HV and LV side easily reconfigurable. The output reaches steady state only in time less than 0.005 sec is the advantages. Its applications are aero space application, E-communication Power Supply, Power Supplies for equipment like computers, medical equipment, printers, and scanners etc., E vehicles.

## 3. SIMULATION RESULTS

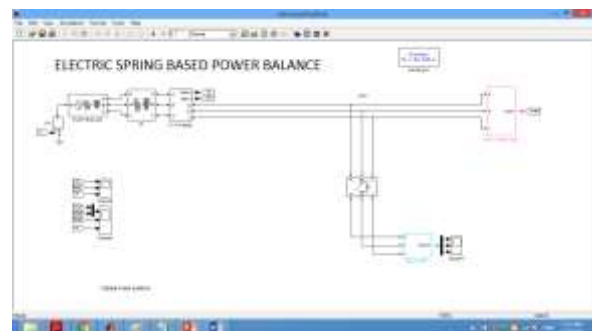

Fig.6. Electric spring based power balance

The figure 6 shows that electric spring based power balance. The electric spring is connected in series with non-critical loads to form a new generation of smart loads by setting the transaction time of breaker at about 0.05 sec. While running the MATLAB simulation after reaching the transaction time, the electric spring will be switched on automatically. That control scheme of such smart loads to reduce power imbalance along with hysteresis band up to 2.5 amps.

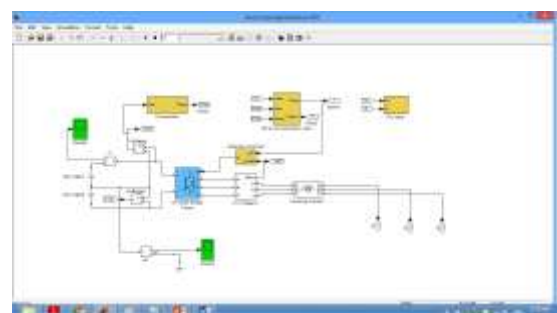
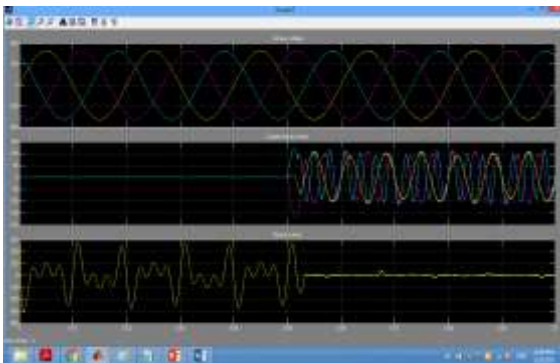

Fig.7. Electric spring alone as sub system

The figure 7 shows that electric spring alone as sub system. The electric spring is in the combination of coupling inductor and capacitor which is used to lead and lag the

received power and also hysteresis controller is provided to control the hysteresis band by using PQ and I compensation.



The waveform shows the clear picture of how neutral current is reduced after placing an electric spring in the circuit. At exactly a time of 0.05s the ES is added. Before that, there is a maximum value of 250A of neutral current. And after the addition of ES, it is reduced to less than 50A scale. Anyhow this depends on the overall load current and power consumed by the loads.

#### 4.CONCLUSION & FUTURE WORK

Faster power quality improvement is a prerequisite for industrial and consumer equipment and ES offers better performance than other state-of-the-art compensation methods. It improves power quality by significantly reducing the harmonic components in currents and correcting the power factor. The results of simulations performed in this work shows that digital control of ES based on p-q theory provide faster power quality improvement than SDM technique. In summing, digital control of ES should be the preferred choice for power quality improvement. The project may be used as a centralized controller to maintain all the buses included in the grid. Presently the scenario has been explained at one bus. Any further optimizations may be included in this work in order to have robust control over power quality parameters. (Presently power quality parameters have not been addressed). The system may be designed as an embedded hardware in order to convert all control algorithms into VLSI based control. Power level may be increased in order to check the robustness of the control algorithms.

#### REFERENCES

[1] N. H. Akagi, Y. Kanazawa, "Generalized theory of the instantaneous reactive power in three-phase circuits," IPEC'83 - Int. Power Electronics Conf., Tokyo, Japan, 1983.

[2] A. von Jouanne and B. Banerjee, "Assessment of voltage unbalance," IEEE Trans. Power Delivery, vol. 16, no. 4, pp. 782-790, Oct. 2001.

[3] B. Singh, K. Al-Haddad, and A. Chandra, "A review of active filters for power quality improvement," IEEE Trans. Ind. Electron., vol. 46, no. 5, pp. 960-971, Oct. 1999.

[4] Lee and S.Y.R. Hui, "Input voltage control bidirectional power converters", US patent application, US2013/0322139, filed 31 May, 2013.

[5] K. Lee, and S.Y.R. Hui, "Reduction of energy storage requirements for smart grid using electric springs", IEEE Trans. on Smart Grid, Vol.4, No.3, Sept. 2013, Page(s): 1282-1288.

[6] Sankaran, Power Quality. CRC press, 2001.

[7] H. W. M. Aredes, "New control algorithms for series and shunt three phase four-wire active power filters," IEEE Trans. on Power Delivery, vol. 10, no. 3, pp. 1649-1656.

[8] W. J. M. Joo Afonso, Mauricio Aredes, "Shunt active filter for power quality improvement," International Conference UIE 2000 - Electricity for a Sustainable Urban Development Lisboa, Portugal, Nov. 2000.

[9] M. Joo Afonso, Carlos Couto, "Active filters with control based on the p-q theory," IEEE Industrial Electronics Society Newsletter, vol. 47, no. 3, ISSN: 0746-1240, 2000.

[10] W. Dixon, J. J. Garcia, and L. Moran, "Control system for three-phase active power filter which simultaneously compensates power factor and unbalanced loads," IEEE Trans. Ind. Electron., vol. 42, no.6, pp. 636-641, Dec. 1995.

[11] A. E. H. Watanabe, R. M. Stephan, "New concepts of instantaneous active and reactive powers in electrical systems with generic loads," IEEE Trans. on Power Delivery, vol. 8, no. 2, pp. 697-703.

[12] S. Janko Nastran, Rafael Cajhen and P. Jereb, "Active power filter for nonlinear ac loads," IEEE Trans. on Power Electronics, vol. 9, pp. 92-96.

[13] J.Vinoth, T.Muthukumar, M.Murugandam and S.Saravanan," Efficiency Improvement of Partially Shaded PV System, International Journal of Innovative Resaerch in Science, Engineering and Technology, Vol.4, Special issue 6, pp.1502-1510, 2015

[14] M.B.Malayandi, Dr.S.Saravanan, Dr. M.Muruganandam, "A Single Phase Bridgeless Boost Converter for Power Factor Correction on Three State Switching Cells", International Journal of Innovative Research in Science, Engineering and Technology, Vol. 4, Special Issue 6, pp. 1560-1566, May 2015.

[15] A.Sasipriya, T.Malathi, and S.Saravanan, "Analysis of Peak to Average Power Ratio Reduction Techniques in SFBC OFDM System" IOSR Journal of Electronics and Communication Engineering, Vol. 7, No.5, 2013.

[16] P.Ranjitha,V.Dhinesh, M.Muruganandam, S.Saravanan, "Implementation of Soft Switching with Cascaded Transformers to drive the PMDC Motor", International Journal of Innovative Research in Science, Engineering and Technology, Vol. 4, Special Issue 6, pp. 1411-1418, May 2015.

- [17] C.Sowmiya, N.Mohanandhini, S.Saravanan and M.Ranjitha, "Inverter Power Control Based On DC-Link Voltage Regulation for IPMSM Drives using ANN" International Research Journal of Engineering and Technology (IRJET), Vol.5, Issue 11, pp.1442-1448, 2018.
- [18] N.Yuvaraj, B.Deepan, M.Muruganandam, S.Saravanan, "STATCOM Based of Adaptive Control Technique to Enhance Voltage Stability on Power Grid", International Journal of Innovative Research in Science, Engineering and Technology, Vol. 4, Special Issue 6, pp. 1454-1461, May 2015.
- [19] P.Manikandan, S.Karthick, S.Saravanan and T.Divya, "Role of Solar Powered Automatic Traffic Light Controller for Energy Conservation" International Research Journal of Engineering and Technology (IRJET), Vol.5, Issue 12, pp.989-992, 2018.
- [20] R.Satheesh Kumar, D. Kanimozhi, S. Saravanan, "An Efficient Control Scheme for Wind Farm Using Back to Back Converter," International Journal of Engineering Research & Technology (IJERT), Vol. 2, No.9, pp.3282-3289, 2013.
- [21] M.Deepa, A.Satheeshkumar and S.Saravanan, "Variable Length Dynamic Shifting Based Lfsr Multiple Scan Chain For Test Compression," IOSR Journal of Electronics and Communication Engineering (IOSR-JECE), pp.13-18, 2016