

Automated Roasting System

Mr. Vishwajeet G. Nalawade¹, Mr. Swapnil B. Manore², Mr. Yash A. Patwardhan³,
Mr. Omkar S. Gaikwad⁴

^{1,2,3,4}PCET's Nutan Maharashtra Institute of Engineering and Technology, Talegaon, Pune, India

Abstract—Automation is future industry. It provides better food product quality and same taste with consistency. Conventional roasting system designed basically with labour engagement in it, where all the roasting procedure takes place manually. There was no automation in roasting techniques. Lots of quality and taste fluctuation occurs with manual method also even separation of heat is not possible. Conventional systems are of bigger in size.

1. INTRODUCTION

As competition increases in food industry. Many brands started spraying their business in multiple locations. Where supply is higher in quantity. Manufacturing rate for higher quantity is also possible major issues are labour engagement and taste variations. Generally, company come up with idea of roaster that is easy to use, detachable, user friendly and automated. The goal is to design roasting machine that is automated, the capacity is larger than Conventional design, and still be detachable. Design process began with the task of analysing the current market and customer needs. Also, through external research, we generated ideas. Roasting temperature is different for different dry fruits. In conventional system it's impossible to set and hold temperature for longer duration of time. Redesign of conventional roasting system is important for food industry.

2. PROBLEM STATEMENT

1. Due to manual food roasting procedure there is major taste variation in dry fruits.
2. It's impossible to hold temperature of conventional system for longer time.
3. There is problem of continuous output from conventional system to the packaging line
4. Requirement of labour for continuous stirring and addition of additives.
5. Pre heating and post heating is impossible on same oven.
6. Low rate of production.
7. Quality Variation issues.

A. Objective

The main objective of this project is to design and manufacture "Automated Multiple product dry fruit roasting machine". The requirement of functions is given below.

1. Machine is made up for high rate of production.
2. Temperature controllers are available for temperature adjustment for multiple product.
3. Continuous output of roasting material for food packaging line.
4. Pre-heating and post heating facility for complete moisture removal.
5. Sprayer mechanism for addition of Addictive (Sault Water or Chilly Water)

Above listed are main objectives of this industrial project which are mainly taken into consideration for new system development.

B. Conceptual project design

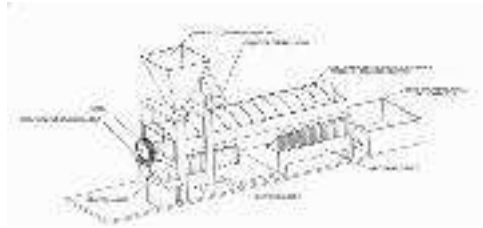

Fig 1: Conceptual project design

C. Working Mechanism



Fig 2: Working mechanism

Above figure is the basic working mechanism of dry fruit roasting machine. The conceptual working of dry fruit roasting is explained below.

The feeder is provided with the feed control mechanism to control the flow of roasting product. With the controlled speed of feed rate, dry fruits are inserted in pre heated oven 1 where the required temperature is already pre-set. In oven 1 the dry fruit starts roasting. With the help of screw conveyor, the material is allowed to travel towards additive addition zone. In this zone the additives are evenly sprayed on the heated roasting product in a controlled manner. With the addition of additives, moisture also added in the preheated roasting product. To remove that moisture material again travel towards post heating chamber where post heating is provided. And finally, fully roasted product travel towards packaging line with the help of conveyor system.

3. MARKET OVERVIEW

In this market overview we are specially focus the overall requirement of ground nuts in the market and total production rate. We also consider the storage issues with the ground nuts. And requirement of this machine for future purpose.

Groundnuts especially those produced in the developing countries have been used traditionally since the origin of humanity. It is rich in oil and protein and has a high-energy value. Developing countries account for nearly 95 percent of world production. Asia accounts for about 70 percent of this amount where the major producers India and China together represent over two-thirds of global output.

The quality attributes that are important for end uses of groundnut vary among the developed and developing countries. Groundnuts are mainly processed for oil in several developing countries. Even though it is a good protein source, the cake obtained after oil extraction is not utilized to the best advantage.

Production of aflatoxin due to the invasion of the fungus *Aspergillus flavus* to groundnut pod/kernel is a serious problem in the trade of groundnuts in the international market, which has seriously hampered the export business of the developing countries. Therefore, these countries can no longer rely on monoculture in order to support their growing economies.

Under current conditions, crop dependency has made producers vulnerable to losses because of the lower prices paid for the pods and kernels. It is, therefore, imperative for them to diversify their production and create added value through processing thereby reducing risks and opening new local and export markets. There is a necessity to investigate new opportunities for the use of groundnut as food and confectionery items.

Most of the developing countries have poor drying and storage facilities. Under these conditions the seed loses its quality and viability in storage rapidly. The purpose of this project is to discuss the importance of the post-production system in developing countries and to suggest suitable curing, drying, storage and processing technologies.

America document the widespread culture of groundnut and provide indirect evidence for its domestication long before the Spanish Conquest. When the Spaniards returned to Europe they took groundnuts with them. Later traders were responsible for spreading the groundnut to Asia and Africa where it is now is grown between the latitudes 40°N and 40°S. China and India together are the world's leading groundnut producers accounting for nearly 60 percent of the production and 52 percent of the crop area. India cultivates about 7.74 million hectares and produces 7.61 million tonnes of groundnut with the productivity level of 991.8 kg ha⁻¹. South Africa is the major producer in Africa, while in Latin America almost one half of the total groundnut produced in that region may be credited to Argentina.

Among the developing countries Egypt has the highest productivity and capacity to produce groundnuts. In most of the developing countries, the productivity levels are lower than in the United States of America, mainly due to a number of production constraints such as. Especially in the developing countries, groundnut has to play an important role both as oil and food crop. For example, in India about 10 kg groundnut per capita are available for domestic consumption. Fat and oil consumption averages less than 5 kg per capita per year. It has been estimated that in the year 2000, approximately 34 million Mt of groundnuts were produced world wider of which 15 million Mt were produced in China, 6 million Mt in India, 2 million Mt in Nigeria, 1.5 million Mt in United States of America and the rest mostly in other countries.

Protein calorie malnutrition (PCM) is a serious problem in the developing world. It is ironic that

PCM exist in areas where most of the groundnut is produced. Assuming the level of production of 34 million Mt of groundnut in year 2000, there would be about 6.26 million metric tons of groundnut proteins (after correcting for the kernel yield). Thus, there should be about 2.6 to 2.8 g of groundnut protein available per capita per day in the world. This translates into approximately 5.5 percent of the total protein requirements of the world.

The obvious reason for low consumption of groundnut protein in India is that out of 6 million Mt of groundnuts produced every year, 80 percent are utilized for oil extraction, 12 percent for seed purpose, 2 percent for export and the remaining for edible purposes. The protein rich cake resulting from oil extraction is fed to the animals as protein supplement. The groundnut utilization system in India is

The system remains more or less similar in most of the developing countries, with the exception of South Africa.

4. METHODOLOGY

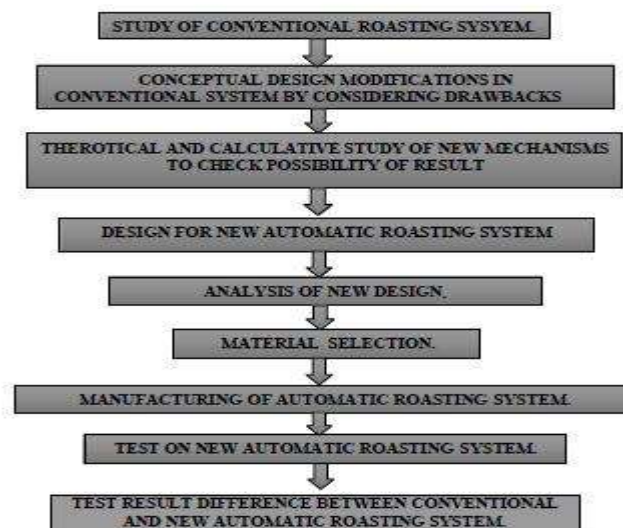

5. PARTS REQUIRED FOR SETUP ASEMBLY

1. Acrylic cover

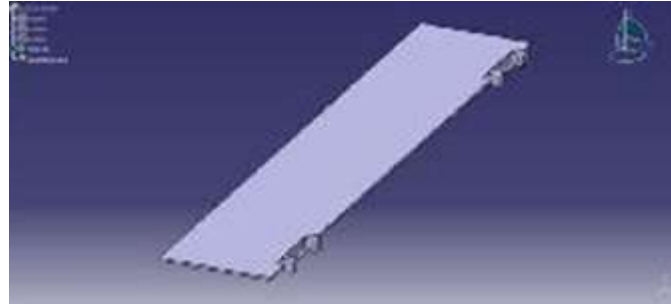

Fig 2: Acrylic cover

No	Parameter	Dimension
1.	Length	120 cm
2.	Width	45 cm
3.	Height	2.5 cm

Material- Acrylic.

Properties:

- Excellent optical clarity.
- Rigid, with good impact strength.
- Excellent dimensional stability and low mould shrinkage.
- Stretch forming increases bi-axial toughness.

Disadvantages and Limitations:

- Poor solvent resistance; attacked especially by ketones, esters, chlorocarbons and aromatic hydrocarbons, freons.
- Subject to stress cracking.
- Combustible.

Use:

It is use to provide protection against dust particles and loss of heat with optical clarity.

2. Roasting Pan



Fig 3: Roasting Pan

NO	PARAMETER	DIMENSION
1	Length	120 cm
2	Width	45 cm
3	Height	32 cm

Material: Aluminium 3000

Properties:

Its softness makes it easy to form into a variety of shapes, but leaves the material prone to scratching, warping, and denting. The higher concentration of manganese in 3003 aluminium makes it harder, more durable, and ideal for medium-duty cookware.

The heaviest-duty aluminium used in foodservice is 3004 aluminium, which is made with at least 1 percent manganese and about as much magnesium, which further bolsters the metal's strength.

Disadvantages and Limitations:

High Cost

Acidic products like vinegar, lemon juice, and cream of tartar work to remove stains from aluminium surfaces.

Avoid using steel wool and metal brushes that can scratch soft aluminium and create a rough surface that food is prone to stick to.

Use: It is use as a heating pan bed for roasting.

3. Bearing Housing

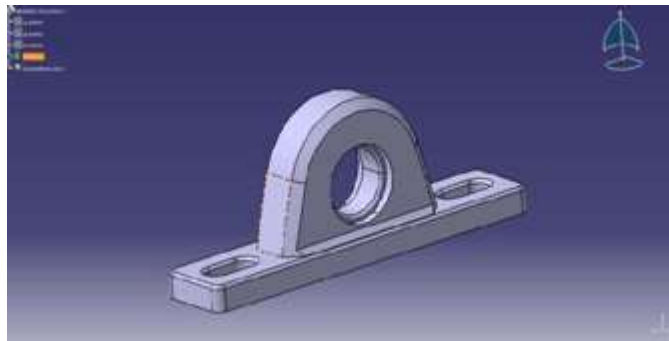

Fig 4: Bearing Housing

Material: Grey cast iron

Properties:

The housing base is reinforced with ribs and has extra material surrounding the holes for the attachment bolts this virtually eliminates any distortion of the base and bearing seat during tightening of the attachment bolts.

The centre cross reinforcement in the housing base increases the contact area between the housing base and the support surface to improve the heat flow from the bearing outer ring to the support surface.

For more efficient re lubrication from the side, SNLN 30 housings have an integrated flange that guides grease from the grease fitting directly to the bearing. Compliance to standards: ISO 113:2010

Disadvantages and Limitations: • High Cost

- Mounting and balancing is difficult.
- Axial alignment is complicated.

Use:

- It is use to hold bearing at fix position.
- Transfer weight of shaft to frame.
- Provide end point limitations to bearing

4. Gear Cover

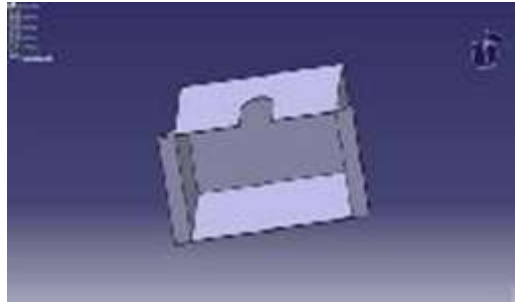

Fig 5: Gear cover

NO	PARAMETER	DIMENSION
1	Length	26 cm
2	Width	18 cm
3	Height	22 cm
4	Thickness	1.25 mm

Material: Cast iron.

Properties:

- Protect gearbox from dust.
- Provide protection to worker.
- Low cost.
- Easy manufacturing.
- Not require proper alignment.

Disadvantages and Limitations:

- Mounting is easy.
- Easy to fabricate.
- Dimensional accuracy doesn't matter.

Use: It is use to provide protection for worker as well as gear box from foreign particles

5. Heater Mounting

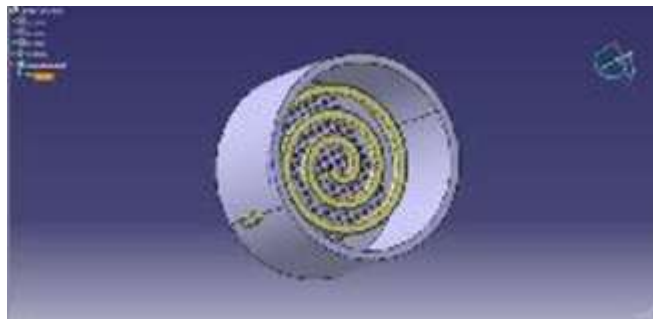

Fig 6: Heater Mounting

SR. NO	PARAMETER	DIMENSION
1.	Inner Diameter	19.75 CM
2.	Outer Diameter	18 CM
3.	Height	12.5 CM
4.	Thickness	1.75 CM
5.	Clearance	0.2 MM

Material: Ceramic material

Properties:

- High rate of heat transfer
- Low weight
- Anti-corrosive
- High thermal stability

Disadvantages and Limitations:

- Highly brittle.
- Difficult to install
- Dimensional accuracy varies with heat treatment

Use: Use to connect heat distributor & heating plate.

6. Gears

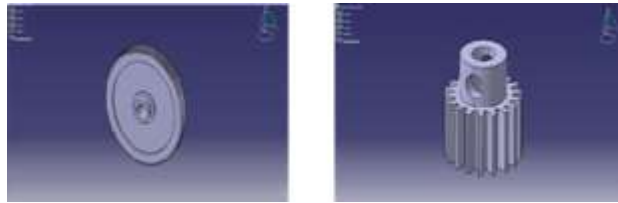

Fig 7: Gears

SR. NO	PARAMETER	DIMENSION
1.	Gear Reduction Ratio	4:1
2.	Clearance	0.2 mm

Material: Cast Iron Properties:

- Gear reduction ratio 4:1
- Use to control speed.
- Transmit power from motor to screw conveyor shaft.

Disadvantages and Limitations:

- Increased noise.
- Difficult to install
- Dimensional accuracy varies with heat treatment

Require greasing.

Use: Use to drive screw conveyor with controlled speed.

7. Screw conveyor blades

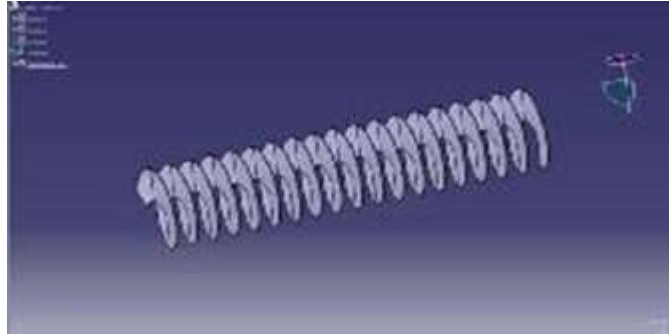

Fig 8: Screw conveyor blades

Material: aluminium Design Considerations:

1. Handling capacity:

Handling capacity is one of the important indicators to measure the production capacity of screw conveyors. It generally depends on the production requirement. However, it is also closely related to the other parameters.

2. Screw blade rotate speed:

The screw blade rotate speed has great effect on handling capacity. In general, if the rotate speed is higher, the capacity of the screw conveyor will be higher, if the rotate speed is too small, the capacity of the screw conveyor will be lower.

3. The screw blade diameter:

The screw blade diameter is the main parameter of screw conveyor, and it is related to the capacity and structure dimension directly.

4. Screw pitch:

Screw pitch not only decides the lead angle of the screw auger, but also decides the slip surface of the material under a certain filling coefficient.

5. Inclination angle:

The inclination angle of screw conveyor has a certain influence on the productivity and power consumption in conveying process.

Use: Use to drive material from starting point to finish point with controller.

8. Thermocouple sensor

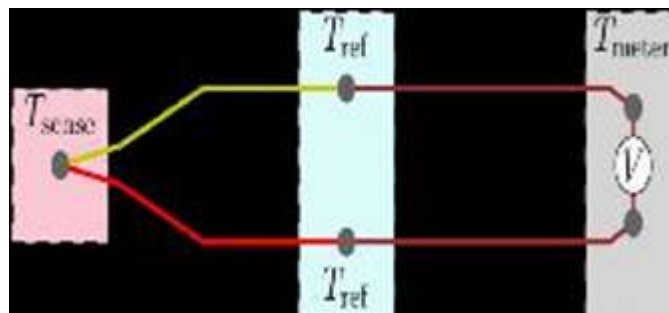

Fig 9: Thermocouple sensor

Working Principle

The working principle of thermocouple is based on three effects, discovered by Seebeck, Peltier and Thomson. They are as follows

Seebeck effect:

The Seebeck effect states that when two different or unlike metals are joined together at two junctions, an electromotive force (emf) is generated at the two junctions. The amount of emf generated is different for different combinations of the metals.

Thomson effect:

As per the Thomson effect, when two unlike metals are joined together forming two junctions, the potential exists within the circuit due to temperature gradient along the entire length of the conductors within the circuit. In most of the cases the emf suggested by the Thomson effect is very small and it can be neglected by making proper selection of the metals. The Peltier effect plays a prominent role in the working principle of the thermocouple.

6. ASSEMBLY

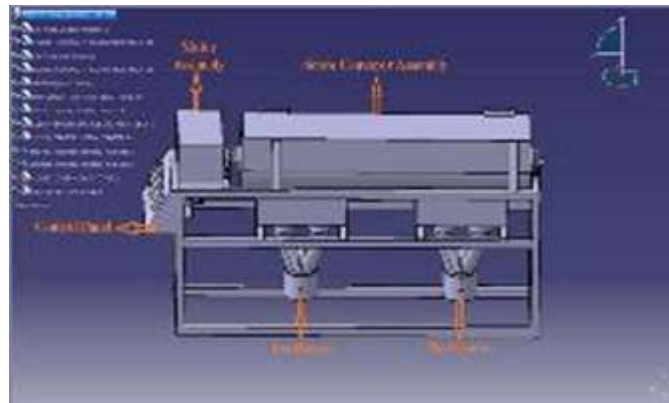

Fig 10: Assembly

ACKNOWLEDGMENT

The acknowledgement is a just drop of the sense of gratitude within our heart for the people who help us out of the most embarrassing part of life when we are standing on the last and most difficult step towards our life. We would like to take opportunity to express our heartfelt thanks to all those peoples who encouraged us during this Project completion path. I feel great pleasure to present the Project entitled "Automated Roasting System". But it would be unfair on our part if we do not acknowledge efforts of some people without the support of whom, this Project would not have been a success.

REFERENCES

- [1] Anran Chen, Shixing Wang, Libo Zhang, Jinhui Peng. Optimization of the microwave roasting extraction of palladium and rhodium from spent automobile catalysts using response surface analysis. doi: 10.1016/j.minpro.2015.08.007
- [2] T. Longvah, Y. G. Deosthale. Effect of dehulling, cooking and roasting on the protein quality of Perilla frutescens seed Elsevier. Received 3 November 1997; revised version received and accepted 15 December 1997.
- [3] Kaye, B.H. Characterizing the flowability of a powder using the concepts of fractal geometry and chaos theory", Particle and Particle System Characterisation 14, 53 – 66. 1997
- [4] Fitzpatrick, J., Barringer, S.A., Iqbal, T. 2004. "Flow property measurements of food powders and sensitivity of Jenike's hopper design methodology to the measured values", Journal of Food Engineering 61, 399 – 405.
- [5] Peleg, M. 1978. "Flowability of food powder and methods for it evaluation-A review", Journal of Food Process Engineering 1, 303 – 328.
- [6] Knowlton, T.M.. "The importance of storage, transfer and collection", Chemical Engineering Progress 90, 44 – 54 1984.
- [7] Jenike, A.W. 1964. "Storage and flow of solids", Bulletin No. 123, Engineering Experiment Station, University of Utah.