

Design of Power Converters for Renewable Energy Sources and Electric Vehicles Charging

SANDESH MADE¹, SNEHAL WAGHMARE², CHANDRAKANT BHALERAO³, PRASHANT BIRAJDAR⁴,
ASHITOSH ANKULGE⁵, SALMA SHAIKH⁶

¹H.O.D, Dept. of Electrical Engineering, Maharashtra, India
²Professor, Dept. of Electrical Engineering, Maharashtra, India
³Professor, Dept. of Electrical Engineering, Maharashtra, India

Abstract - This paper describes the design and construction of a new series of power converters equipped with liquid cooling system. This power series is created for project ENET – Energy Units for Utilization of non Traditional Energy Sources. First power converter is determined for stationary battery system use, the second one is used as an inverter/rectifier for a small solar plant system and the last power inverter is used as a fast charger for electric vehicles. Energy balance is performed for the fast charger converter, which is solved using numerical simulations of the system.

Key Words: Design, efficiency, fast charger, power inverter

1. INTRODUCTION

The present energetic development is oriented into the considerable incorporation of alternative and renewable energy sources into the standard electrical grids in an effort to build very efficient, economic and reliable smart grids. This approach produces a series of technical problems, which have to be solved. One of the most actual ones is the electric energy accumulation. The solar plant systems and especially the fast charger stations for electric vehicles and many other applications are the typical examples, which will be discussed further.

To satisfy an efficient and economic functioning of such station, the energy surplus has to be stored into the batteries and extracted back when necessary. It is also necessary to ensure sufficient battery power for fast charging of the electric vehicle's traction batteries. These power converters are needed to provide an efficient and reliable energetic power flow between the accumulation units and other devices.

1.1 Reversible Voltage Inverter

The energy storage system for which it is necessary to create a 3-phase voltage inverter with the two-way flow of energy arises in the project ENET. This inverter has several important functions in relation to the electrical grid. The most important of these are the link between energy storage batteries and electrical grid, correction element of the electrical grid, backup power mode for the position in the island mode seized power operation and a few other less important functions. Due to the required converter's functions and inclusion in the traction which is linked with the specified output type, the inverter power output is preset to about 70 kW. The proposal indicates that the expected converter power losses will be in the order of several kilowatts. Voltage level on the DC side varies from 380 to 450 V. On the electrical grid side, the converter is connected to the 230 V mains. Therefore, the converter's nominal output current is 180 A.

Brief look on the power circuit of the converter indicates that it is a simple 3-phase unit consisted of IGBT modules. These modules are connected via/to the system bus. The DC circuit capacitor bank is included. The capacitors are designed for rapid exchange of energy necessary for the proper function of the converter. Due to power losses mentioned above would not be appropriate to use an air cooling system, therefore the liquid cooling system is used instead [2],[7].

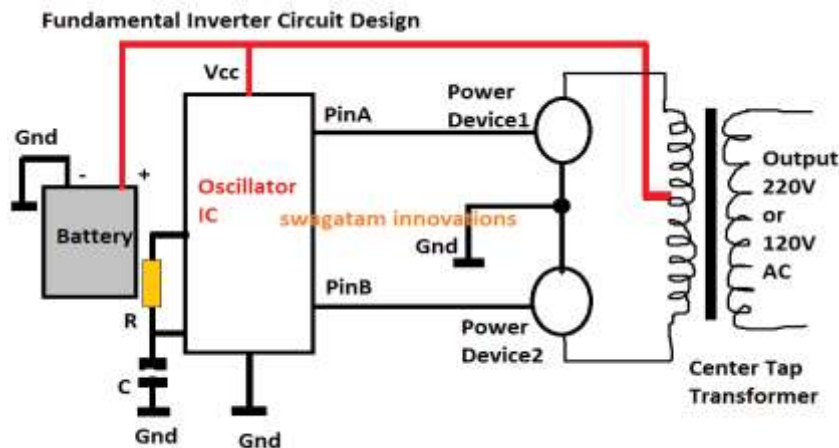

Fig. 1: Circuit topology in which the converter is located



Fig. 2: Sample of design solutions of the reversible voltage in-verter. The first appearance of the inverter is shown in the basic position. On the other illustrations, there are several views inside the inverter

The converter is controlled by a control system which was directly invented for a series of these converters utilizing the digital signal processor TMS 320F28335. This control system includes several signal inputs for real-time circuit measurements. Furthermore, the 12 PWM channels and analog outputs are used for service purposes [5].

1.2 Power Inverter for Solar Power Plants

Nowadays, there are lots of solar power plants with inefficient time-average power operation, which brings the idea of surplus energy accumulation. Realization of this idea requires the storage system with energy storage capacity of about hundreds of kVA. Such a system can be situated in a shipping container which is easy to install in the desired location and would include a set of batteries for the accumulation of electrical energy surplus and support equipment for the operation of the system.

For the function of the storage system is necessary to use the power converter enabling transformation of AC power to DC for battery charging, and vice versa for converting DC power to AC to supply the energy to the electrical grid. This converter is placed between the electrical grid and the battery pack, see Fig. 3.

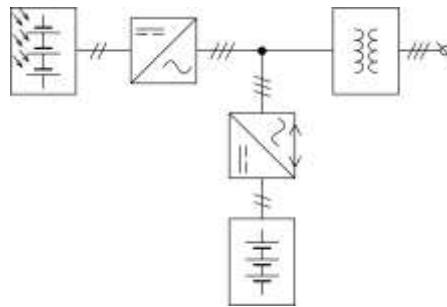

Fig. 3: The circuit topology in which the converter is located

The inverter is designed as the AC connection between electrical grid and the storage batteries. When there is an energy surplus in the electrical grid, the energy produced by the solar power plant will be stored in battery storage. Conversely, in a time when solar power does not produce electricity or produces very little and in the grid is a requirement for power delivery, the energy is pumped from a storage battery to the grid. These particular modes of operation place demand on a 3-phase pulse rectifier and a 3-phase pulse inverter. The topology of these converters enables utilization of the same equipment which can work both as rectifier or inverter [8].

Power converter will be operated on the AC power supply with the parameters of 3 400 V/50 Hz, and storage batteries with a capacity of 600 kVA. Due to the optimal utilization of the inverter the nominal output power is 60 kW. The connected battery will have a nominal voltage of 800 V which at fully charged state gives approximately 1000 V. This value has to be therefore rated for the maximal inverter voltage. The inverter will be operated in a closed air-conditioned container. To ensure an adequate dissipation of heat generated during operation of the inverter, there will be also used a liquid cooling system.



Fig. 4: Sample of design solutions of the power inverter for the solar plants. The first appearance of the inverter is shown in the basic position. On the other illustrations, there are several views inside the inverter

The inverter is designed as a 3-phase bridge converter. DC converter circuit is equipped with a capacitor bank made up of DC link capacitors in cylindrical cases. The 3-phase bridge is assembled from insulated IGBT module

1.3 Fast Charger for Electric Vehicles

Present days are a field of growing electromobility. For its further development is necessary to build a network of charging stations. The ENET project thus develops fast charging stations for electric vehicles.

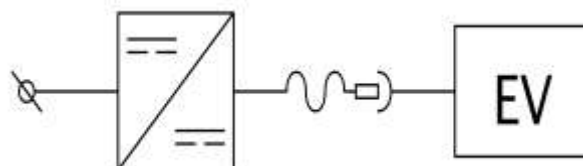

Fig. 5: The circuit topology in which the converter is located.

The concept of this converter is very similar to the previous one, but this time it is a three-arm DC buck converter. Power level of this converter is preset to 70 kW. This performance is chosen to maximize the possibility of batteries charging for electric vehicles. The input voltage of this inverter is about of 800 V DC. The

charged battery voltage must always be lower than the source voltage. The capacitor bank volume/capacity is reduced, in comparison with the previous converter [3],[4].

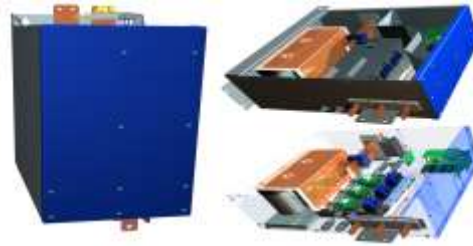

Fig. 6: Sample of design solutions of the fast charger for electric vehicles. The first appearance of the inverter is shown in the basic position. On the other illustrations, there are several views inside the inverter

The insulated IGBT modules are used again as switching components in the fast charger. The current and voltage sensors are distributed in the power circuit providing feedback for the PI controllers. The control algorithms are provided by the control system equipped with a digital signal processor TMS 320F28335, which was developed on the Department of Electronics [6].

1.4 Efficient Fast Charger Structure

The DC Buck converter for charging of electric vehicles is one of the important parts of our development. Therefore, we started a detailed solution of partial tasks towards its realization. One of the tasks is the selection of the specific structure of such inverter. Another one is to calculate and verify the power losses in the mathematical simulation. These tasks are presented in this article. Among other tasks is the design of control systems and their algorithms. The correctness of design and proper function of the converter are partially guaranteed by results of performed simulations and they will be definitively verified after converter's realization. The converter will be incorporated into the power structure arising in the ENET project. Charging efficiency is very important factor in the possibility of wider application. From an economic point of view it is necessary to transfer the energy to the battery with the lowest possible losses. In technical terms the losses cause other issues that need to be reflected in the charging station design. However, there are always power losses, so there is a need to identify and ensure the use of proper cooling equipment [1]

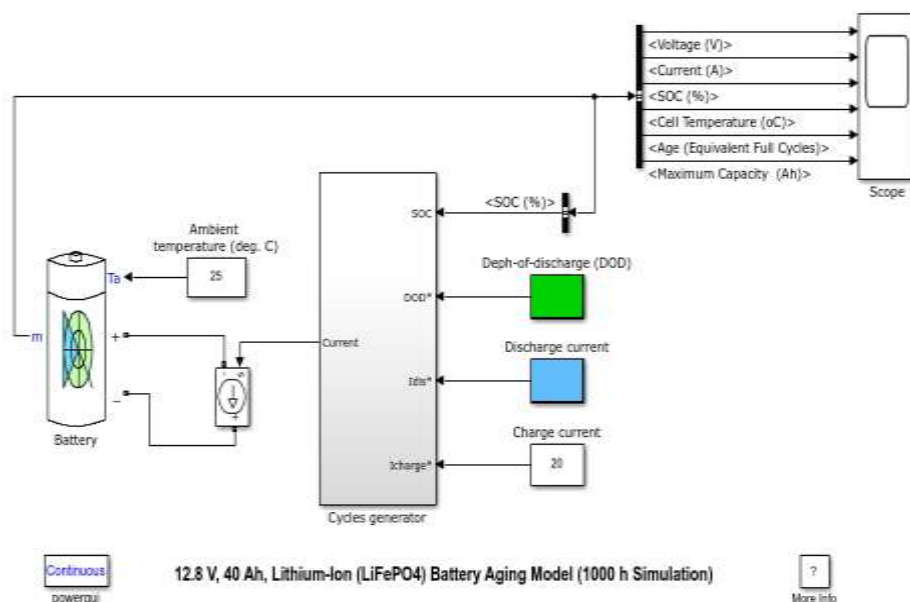

Fig. 7: Model of battery charging simulation

Conclusion

This paper presents the design and construction of liquid cooled series of power converters for renewable energy plants or smart grid systems targeted on the electric energy accumulation. The reversible voltage inverter is fully operational in these days and the future work will be focused on the control algorithms optimization in order to enhance the efficiency of the inverter. The power converter for solar plans and the fast charging unit were fully designed and their manufacturing documentation was created. The future work will be focused on the realization of prototypes and following tests. There will also be a measurement of actual power losses and the consequent total efficiency on the real fast-charging station, which is now being built.

References

- [1] CHLEBIS, Petr and Jan DUDEK. Comparison of Power Losses and Quality of Output Voltage from Different Types of Inverters. In: 35th Annual IEEE Power Electronics Specialists Conference. Aachen:
- [2] IEEE, 2004, pp. 3120–3126. ISBN 0- 7803-8399-0. DOI: 10.1109/PESC.2004.1355334.
- [3] VACULIK, Petr, Ales HAVEL, Martin TVRDON and Michal HROMJAK. The Design and Con-struction of a Reversible Voltage Inverter Proto- type. In: 13th International Scientific Conference Electric Power Engineering 2012. Brno: FEKT VUT, 2012, pp. 1059–1062. ISBN 978-80-214- 4514-7.
- [4] CHLEBIS, Petr, Ales HAVEL, Petr VACULIK and Zdenek PFOF. Modern Instruments for In- creasing the Efficiency of the Energy Transfer in Electric Vehicles. In: 14th EPE-PEMC 2010 In-ternational Power Electronics and Motion Control Conference. Ohrid: IEEE, 2010, vol. 14, pp. 89–93. ISBN 978-1-4244-7854-5.
- [5] JUNG-SONG, Moon, Lee JUNG-HIO, He IN- YONG, Lee TEACK-KIE and Won CHUNG- YUEN. An Efficient Battery Charging Algorithm Based on State of-charge Estimation for Elec-tric Vehicle. In: International Conference on Electrical Machines and Systems (ICEMS). Bei-jing: IEEE, 2011, pp. 1–6. ISBN 978-1-4577-1044- 5. DOI: 10.1109/ICEMS.2011.6073783.
- [6] BRANDSTETTER, Pavel, Pavel BILEK, Josef SZOTKOWSKI and Petr VACULIK. Measure-ment and Signal Processing for Electric Drive Control System. In: Progress in Electromagnet- ics Research Symposium. Marrakesh: The Elec- tromagnetics Academy, 2011, pp. 1416–1420. ISBN 978-1-934142-16-5.
- [7] HAVEL, Ales, Petr VACULIK and David SLIVKA. Efficient Propulsion Structure with Anaxial Flux Rotary Converter for HEV Drive Unit. Advances in Electrical and Electronic Engineering. 2011, vol. 9, no. 3, pp. 136–142. ISSN 1336-1376.