

# Implementation of VPN, AWS Cloud Enabled Real Time Water Pollution System

Prof. Leena Patil<sup>1</sup>, Devika Salunkhe<sup>2</sup>, Arundhati Kahate<sup>3</sup>, Antoinette Fernandes<sup>4</sup>

<sup>1</sup>Professor, Dept. of Electronics and Telecommunication, Xavier Institute of Engineering, Mumbai, Maharashtra, India

<sup>2,3,4,5</sup>Student, Department of Electronics and Telecommunication, Xavier Institute of Engineering, Mumbai, Maharashtra, India

\*\*\*

**Abstract-** Virtual private network is a communication environment. The characteristic of this environment is private and secured. This kind of privacy is virtual, i.e. to achieve this kind of privatization through virtual way instead of physical way. The traditional water monitoring systems require periodic manual intervention for both monitoring and maintenance it has several drawbacks. Therefore, there is a clear need for real time water pollution monitoring system with remote location access. The aim of this project is to build different networks and securing the connection through VPN while simultaneously monitoring the pollution waste.

**Key Words:** Water Quality, pH level, Temperature, Turbidity, Water level, IOT, Wi-fi (ESP8266).

## 1. INTRODUCTION

Virtual Private Network (VPN) is rapidly growing technology which plays a great role in Wireless LAN (WLAN) by providing secure data transmission. Internet Protocol Security (IPsec) is used to implement cryptographic security services to protect communications over IP Networks [1]. First part will be to configure the IP address, Subnet address and gateway address to build two different networks. For security purpose, VPN will be used to create secure connections to protect traffic that flows between controlled and trusted endpoints. The standard method of testing water quality is to gather water samples and send it to the lab for testing and analyzing. This method is less effective in terms of time, man power and inexpensive. The water quality monitoring that we have carried out examines the quality of water in real time through several sensors (parameters: pH level, temperature, turbidity, water level) to compute water quality. The presence of pollutants can be examined through difference in the value of parameters. The Wi-fi module in the monitoring system transfers data which are collected by the sensors to the microcontroller, and transfers the data to the device. This system can keep an authoritarian check on the water pollutants and provide accurate results to eradicate water pollution.

## 2. LITERATURE REVIEW

VPN uses various protocols for securing virtual network connections. IPsec is one among the foremost reliable

VPN protocols for securing network connectivity. It is an appropriate VPN protocol for connecting between the most campus with the remote campus. Because IPsec uses a tunnel between two end connections, the knowledge is safer and reliable through an IPsec VPN. The IPsec protocol may be a standard university during a developing country because it doesn't cost much and easier to configure. The main campus can configure the IPsec VPN without in-depth. Multi-VLANs are widely designed and deployed within the business and education sectors, to provide comfortable and secure network management. For each network, there are several applications installed, like VoIP, Wireless Access Point, LAN, Server farm, IoT devices. Each VLAN design should be safe and secure. This paper describes the VLAN design and implementation of multi-application between two campuses of University. This research shows three benefits of Multi-VLAN design, first, it is very cheap due to deployment of multiple sorts of applications, second, it increases protection and security. The two commonest sorts of VPNs are remote-access VPNs and site-to-site VPNs [1]. A remote-access VPN uses a public telecommunication infrastructure just like the internet to supply remote users with secure access to their organization's network; this is often especially important when employees are using a public Wi-Fi hotspot or other avenues to access the web and hook up with their corporate network. A VPN client on a foreign user's computer mobile device connects to a VPN gateway on the organization's network. The gateway typically requires the remote device to authenticate its identity. Then, it creates a network link back to the device that permits it to succeed in internal network resources e.g., file servers, printers, and intranets as if the gateway is on the network locally.

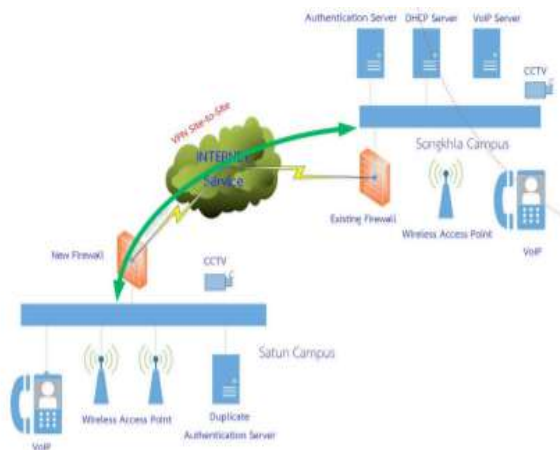

Fig-1: Campus Network VPN

The growing interest in the smart device/home/city has increased in the popularity of the Internet of Things (IoT) deployment. However, because of the open and heterogeneous nature of IoT networks, there are various challenges to deploy an IoT network, among which security and scalability are the highest two to be addressed. To improve the safety for IoT networks, we propose a Software-Defined Virtual Private Network solution, during which each IoT application is allocated with its VPN. The VPN tunnels utilized in this paper are VxLAN based tunnels and that we propose to use the SDN controller to push the flow table of every VPN to the related OpenvSwitch via the OpenFlow protocol. The SD-VPN solution can improve the safety of an IoT network by separating the VPN traffic and utilizing service chaining. Meanwhile, it also improves the scalability by its overlay VPN nature and therefore the VxLAN technology [2]. The majority of VPN services are provisioned manually. Consequently, it may take a few days to build the VPN services, as a variety of configurations need to be changed. The manual process delays new service implementation and increases operational cost and complexity. As we all know, SDN provides network simplification and automation, it is effective to provide the VPN services via SDN and this is so-called SD-VPN. In other words, instead of creating VPN services manually in advance, SD-VPN creates VPN services automatically when a VPN client joins. SD-VPN can provide VPN services automatically. In other words, SD-VPN can establish VPN tunnels and connect two endpoints into their VPNs automatically. Also besides, the routing table of the overlay VPN service is built by the SDN controller at the same time when the VPN is created, and the controller can push the routing table to every involved router or switch via OpenFlow. The SDN controller can be implemented as a dedicated or virtual server. Its north-bound API towards the orchestration layer is to get the overlay network service template and policies, while the south-bound OpenFlow interface is to push the overlay network configuration and flow tables to the OpenvSwitch on the edge devices. The proposed solution can be applied to various types of IoT applications, such as remote control of smart appliances, remote control of home

temperature, smart TV/mobile TV connection to content delivery networks (CDNs) and autopilot of smart cars[2]. Water quality is decided by various physicochemical and biological factors, as they may directly or indirectly affect its quality and consequently its suitability for the distribution and production of fish and other aquatic animals (Moses, 1983). Many workers have reported the status of water quality characteristics (physical, chemical and biological). Fish do not like any kind of change in their environment. Any changes add stress to the fish and therefore the larger and faster the changes, the greater the strain[3]. So the maintenance of all the factors becomes very essential for getting maximum yield during a fish pond. Good water quality is characterized by sufficient oxygen, temperature, transparency, adequate levels of metabolites and other environmental factors that are affecting fish culture. A sharp drop or an increase within these limits have an adverse effects on their body functions. Water quality is decided by variables like temperature, transparency, turbidity, water color, CO<sub>2</sub>, pH, alkalinity, hardness, unionized ammonia, nitrite, nitrate, primary productivity, BOD, plankton population, etc. In this paper, the implementation was done using Raspberry Pi and AWS IOT technology. Therefore, good water quality is very essential for the survival and growth of fish. Thus to meet the demand of present food supply, water quality management in fish ponds is a necessary step that is required to be implemented.

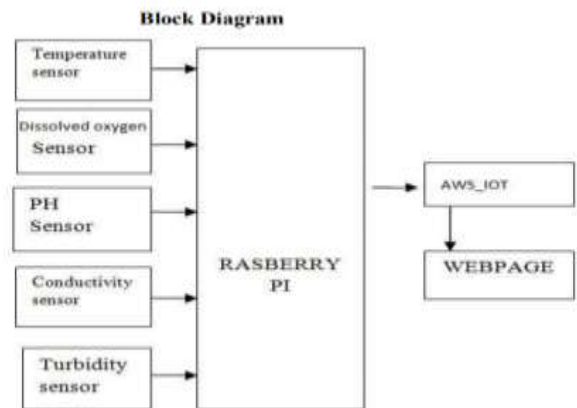

Fig-2: Water Quality Monitoring System

Real-time water quality observation is examined by data acquisition, method, and transmission with a rise within the wireless device network method within the IoT. Microcontrollers and thus the processed values remotely to the core controller ARM with a WI-FI protocol are familiar with interfacing the measured values from the sensors. This paper describes ensuring the safe supply of quality should be monitored in real-time based water quality monitoring has been proposed[4]. In this paper, we present the design of an IoT based water quality monitoring system that monitors the quality of water in real-time. This system consists of some sensors which measure the water quality parameter such as pH, turbidity, conductivity, dissolved oxygen, temperature.

The measured values from the sensors are processed by microcontroller and these processed values are transmitted to the Raspberry Pi. Finally, sensors data can view on internet browser applications using cloud computing. This paper emphasizes the water quality monitoring methods, sensors values and knowledge dissipation procedure. It also explores the Sensor Cloud domain. While automatically improving the water quality isn't feasible at this time, efficient use of technology and economic practices can help improve water quality and awareness among people. This proposed block diagram consists of several sensors is connected to the core controller. The core controller is accessing the sensor values and processing them to transfer the information through the web. Arduino is used as a core controller. The sensor data are often viewed on the web wi-fi system. Aquaculture is one of the prospering segments in developing countries like India as it contributes 1.07 percent of the GDP. It is found that fish necessity of the country by 2025 would be in terms of 1.6 crores tones and due to the overfishing regular fisheries have been drained therefore commercial aquaculture has been appeared[5]. Aquaculture comprises the arrangement of exercises, information and methods for the rearing of underwater plants and a few types of animals in the water. This action has incredible significance in monetary advancement and food development. The aim of this project is to design and execute a distributed system for aquaculture water quality care through remote monitoring of turbidity, temperature and pH. This work will contribute remote monitoring system through IoT to screen water quality monitoring in ponds. This water monitoring framework is portable, low cost, versatile and implies sharing of data through the cloud that can be used for the improvisation for aquaculture related activities. The methodology executed can facilitate the aquafarmers for the precise and reliable observance of water parameters, the actual fact that manual testing will take longer and water quality parameters could change with time It additionally takes pro-active measures before any harm was done[5]. Despite the fact that the primary cost is high, there will be no extra expense and maintenance once it is installed. Thus, the framework implemented will reach the farmers for reducing the harm from climatic changes and confirms growth and health for aquatic life. This improves productivity, helps in improving foreign trade and increases the GDP of the country. More the gathered information can be inspected utilizing big data analytics and necessary steps can be taken before the water quality parameter crosses the edge value range. The aqua-system automated using IoT, decreases the energy, cost and consumption. Water is one among the foremost essential natural resources for the existence and survival of the whole life. This paper concentrates on designing a sensor to measure factors like CO, ammonia, chloride, nitrate, turbidity, and hardness to decide the quality of water monitoring system[6]. In the proposed smart WQM (Water Quality Monitoring) framework, a reconfigurable sensor interface gadget that coordinates information gathering, information preparing,

and remote transmission are outlined. The equipment of the remote water quality checking framework contains the accompanying parts: 1. Ultrasonic Sensor 2. pH Sensor 3. Digital Thermometer Sensor 4. Turbidity Sensor 5. CO2 Sensor. In the smart WQM system, when the sensor board is switched on, the sensors are activated to stumble on the individual water parameter information. Then, the accumulated water parameters are transmitted wirelessly to a tracking tool. The statistics of water stage, pH, turbidity, carbon dioxide and temperature are displayed on the WQM dashboard at the pc the usage of Python codes. Then, the gathered water parameters are transmitted remotely to checking gadgets which are PC utilizing the Nios II programming program in the Altera Quartus II programming. The information on the water level, pH, turbidity, carbon dioxide, and temperature are shown on the WQM dashboard on the PC utilizing Python codes. The perusing of water level is changed when the separation between the water surface and the water level sensor is changed. The readings of a water temperature change as indicated by the expanding and diminishing of the water temperature by utilizing warm water and ice water. The scope of the esteem is shown for the observing of pH, temperature, turbidity, carbon dioxide and level of water. In the era evaluation of networking and wireless networks has are available information and communication technology, there are so many things that give facility to deal with this technology using the internet. On the internet, email security is the main aspect and the process of cryptography plays an important role to provide security to the networks. To improve security and efficiency, most email system adopts Public Key Infrastructure (PKI) because the mechanism to implement security, but public key infrastructure-based systems suffer from expensive certificate management and problems in scalability[7]. The main objective of the paper is awareness of email security and its requirements to the common computer users. Several cryptographic techniques are developed for achieving secure communication. The proposed mailing system is secure against the standard security model. Cryptography provides many security goals to ensure of privacy of data, on-alteration of data and so on. The idea of encryption and encryption algorithm by which we will encode our data secretly code and not be ably readable by hackers or unauthorized persons even it's hacked. The main reason for not using encryption in email communications is that current email encryption solutions[7]. This paper gives an in-depth study of Cryptography Techniques like AES, DES, 3DES, Blowfish, RSA, CL-PKC. Among those algorithms and ideas, the safety for the information has become highly important since the selling and buying of products over the open network occur very frequently. In this paper, it has been surveyed about the existing works on encryption techniques. This paper presents the performance evaluation of selected symmetric cryptographic algorithms. Firstly it was concluded that Blowfish has better performing than other algorithms. In the future, we will use encryption techniques in such some way

that it can consume less time and power of furthermore and high speed and minimum energy consumption.

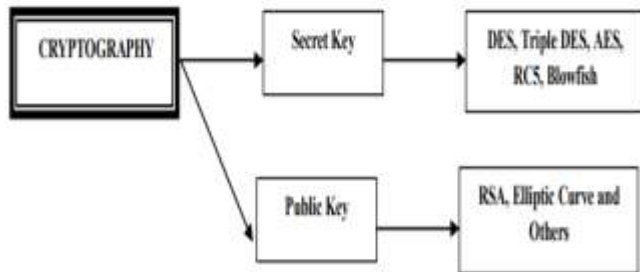

**Fig-3:** Classifications of Cryptography

### 3. CONCLUSION

In this research, Multi-VLAN design and implementation of multi-application between two campuses to provide comfortable and secure network management are described. The SD-VPN solution can improve the safety of an IoT network by separating the VPN traffic and utilizing service chaining. The design of an IoT based water quality monitoring system that monitors the quality of water in real-time is elaborated. Aquaculture comprises the arrangement of exercises, information and methods for the rearing of underwater plants and a few types of animals in the water. In the smart WQM (Water Quality Monitoring) framework, a reconfigurable sensor interface gadget that coordinates information gathering, information preparation, and remote transmission are outlined. The objective of the paper regarding awareness of email security and its requirements to the common computer users is also explained. The paper gives a brief study of Cryptography Techniques like AES, DES, 3DES, Blowfish, RSA, CL-PKC.

### 4. REFERENCES

[1] Sasalak Tongkaw, Aumnat Tongkaw, Multi-VLAN Design over IPsec VPN for Campus Network. 2018 IEEE Conference on Wireless Sensors, At Langkawi, Malaysia.

[2] Shif, L., Wang, F., & Lung, C.-H. (2018). Improvement of security and scalability for IoT network using SD-VPN. NOMS 2018 - 2018 IEEE/IFIP Network Operations and Management Symposium. I. S. Jacobs and C. P. Bean, "Fine particles, thin films and exchange anisotropy," in *Magnetism*, vol. III, G. T. Rado and H. Suhl, Eds. New York: Academic, 1963, pp. 271–350.

[3] Kamuju Sai Divya, Roja Manchala, Sanju Kumar N T, Smart Aquaculture Monitoring system using Raspberry-Pi AWS IOT. International Journal of

Science, Engineering and Technology Research (IJSETR) Volume 6, Issue 8, August 2017, ISSN: 2278-7798.

[4] He, D., & Zhang, L.-X. (2012). The water quality monitoring system based on WSN. 2012 2nd International Conference on Consumer Electronics, Communications and Networks (CECNet).

[5] Preetham.K and Mallikarjun B.C, K.Umesha, Mahesh F.M. Neethan S. Aquaculture Monitoring and Control System: An IOT Based Approach. International Journal of Advanced Research, Ideas and Innovations in Technology, Volume 5 Issue 2, 2019.

[6] Karthick.T, Gayatri Dutt, Tarunjot Singh Kohli and Snigdha Pandey. Prediction of Water quality and smart water quality monitoring system in IOT environment. International Journal of Pure and Applied Mathematics, Volume 118 No.20 2018, 3969-3977.

[7] A. Joseph Amalraj and Dr. J. John Raybin Jose. A Survey Paper on Cryptography Techniques. International Journal of Computer Science and Mobile Computing, IJCSMC, Vol.5 Issue 8, August 2016.