

Development and Fabrication of Automatic Chakali Making Machine

Kousar A. Attar¹, Sammed A. Patil², Prafull D. Patil³, Akash D. Sutar⁴,

Shrinivas A. Patil⁵, Girish Bartake⁶

^{1,2,3,4} B. Tech Students, ⁵ Professor, ⁶ Sponsorer,

^{1, 2, 3, 5} Department of Electronics & Telecommunication Engineering,

⁴ Department of Mechanical Engineering,

^{1, 2, 3, 4, 5} D.K.T.E Society's Textile and Engineering Institute, Ichalkaranji, Maharashtra, India,

⁶ Microtech, Kagal Hatkanangale 5 Star MIDC, Kolhapur, Maharashtra, India

Abstract - Automation is the control of machines and processes by independent systems through the use of various technologies which are based on computer software or robotics. Automation is now a necessity in the food industry to address the required levels of quality control, production speed, labor shortages and overall profitability. Automation has taken over where humans were once commonplace. Industry decision-makers know that plant systems must constantly evolve to meet consumer requirements/demands. This means upgrading existing equipment or purchasing new equipment. Food manufacturers look towards automating their manufacturing processes because of highly competitive retailers constantly squeezing down prices, rising raw material costs and soaring utility charges in a labor-intensive manufacturing environment. Automating food production can reap many benefits. The ability to replicate the appearance and quality of a product with the minimum use of ingredients not only improves line efficiencies leading to bottom-line profit, but also can potentially increase sales. At the same time, improving the traceability of raw ingredients will provide the added benefit of improved food safety.

Key Words: PLC, Industrial Automation, Machine, Servo motor, Chakali, Murukku.

1. INTRODUCTION

Industrial automation is the use of control systems, such as computers or robots, and information technologies for handling different processes and machineries in an industry to replace a human being. It is the second step beyond mechanization in the scope of industrialization. It improves the rate of production through superior control of production. It helps to produce bulk by significantly reducing product processing time with better quality. Therefore, a given labor input it produces a large number of results.

Chakali is a savory snack from India. It is a spiral shaped, pretzel like snack with a spiked surface. Chakali is typically made from flours of rice, Bengal gram and black gram. It is several variations, depending on the type and proportion of

flours used murukku, a similar snacks typically made without the Bengal gram flour, is also sometimes called chikki.

In food industry automation can be beneficial for improving hygiene and quality of food. Moreover it has high productivity, quality, safety, flexibility, accuracy. Introducing automation can give quality Chakali in uniform shape and sizes. It can also help to reduce the labor cost, time and work load. Automatic machine can give high speed with more accurate shape of chakali.

1.1 PROBLEM DEFINITION

Traditionally, Chakali is made by hand using chakali mould. In small industries also use this method because of automated machines are very expensive to purchase. Therefore, they have to use more labour power as well as its very slow production. Problems with conventional system are as follows,

- 1) Time consuming.
- 2) Accuracy.
- 3) Labour intensive.
- 4) Non-hygienic.
- 5) High cost of production.

2. METHODOLOGY

2.1 Block Diagram

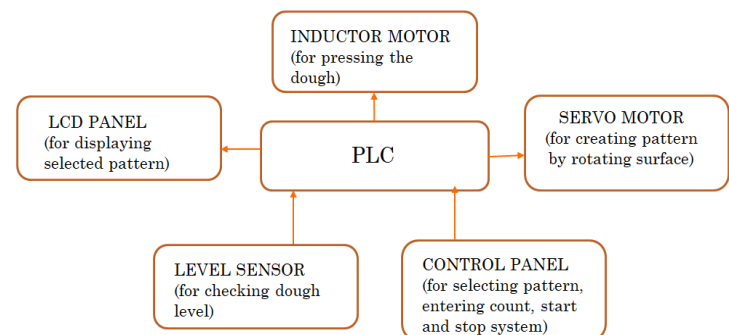

Fig – 1: Block Diagram of system

2.2 Flow Chart

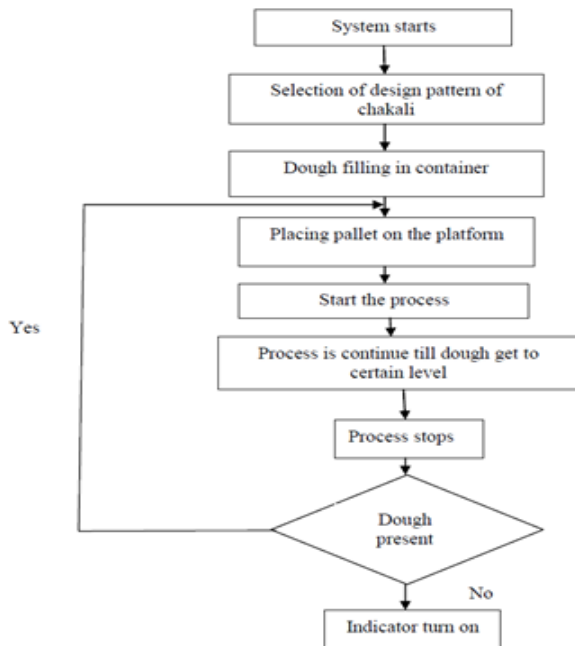

Fig- 2: Flow chart of system

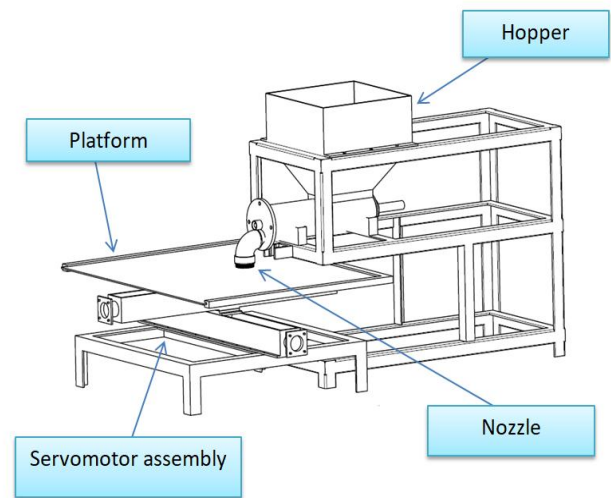

Fig- 3: Mechanical design of system

2.3 System Operation/ Working

The flow chart shown in Fig- 2, gives a detailed explanation of the various processes taking place in complete system. Automated Chakali manufacturing set up firstly we have to select the pattern of Chakali. Then fill hopper with premade dough, which can hold up to 5 Kg of chakali dough. When the hopper is full then system gives indication of system OK and it is shown by indicator on control panel. Place the pallet on platform and start the process by pressing start button on HMI. System ON, Level sensor is the inputs to PLC. Controller gives input to motors. Induction motor is connected to spiral auger which squeeze the dough and dough come out through nozzle of hopper. As shown in Fig- 3, two servo motors are connected to control shaft in perpendicular to each other to perform circular interpolation so, pattern can generated. After completing one chakali cutter joined near nozzle cut the chakali, simultaneously platform moves forward to make place for another chakali. As shown in Fig- 4, if first chakali is done then platter will move horizontally till one row is complete. When one row is complete then it will switch to another row till that row gets filled up by chakalies. This process will continue till platter is full. Meanwhile, level sensor constantly checks level of dough in hopper and give indication whether it's empty or not. LCD display will show the progress of system like count of Chakalies, selected pattern of chakali, etc.

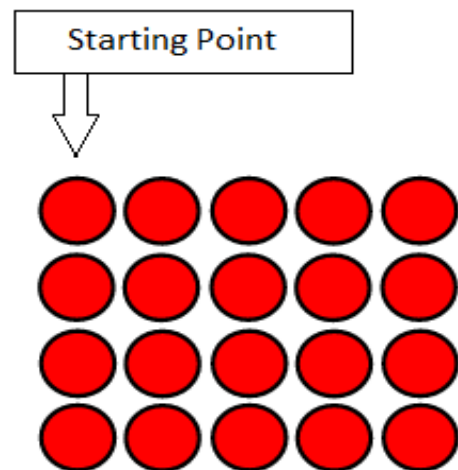

Fig- 4: Array of Chakalies

Different patterns of chakali are created by movements of servo motors joined to pallet. This pattern is provided to motors through ladder program of PLC. The proposed system has 4 patterns as shown in Table- 1.

Number of pattern	Pattern
1	Spiral
2	Square
3	Circle
4	Circular coil

Table- 1: Pattern choices

3. PRACTICAL IMPLEMENTATION

3.1 Working Components

A. Hopper

Food processing hoppers are holding containers utilized for dispensing dough. This containment vessels assist in better management of foods being processed and are also used for short storage or collection of dough. Hopper is a large, pyramidal shaped container used in system (as shown in Fig- 3) to hold dough. It can store up to 5 kg of dough at a time. It is made of steel.

B. Spiral Auger

A spiral auger is a mechanism that uses a rotating helical screw blade, called a "*flighting*", usually within a tube, to move dough (As shown in Fig- 5). It is used horizontally as an efficient way to move dough. It consists of a trough or tube containing a spiral blade coiled around a shaft, driven at one end and held at the other. The rate of volume transfer is proportional to the rotation rate of the shaft.

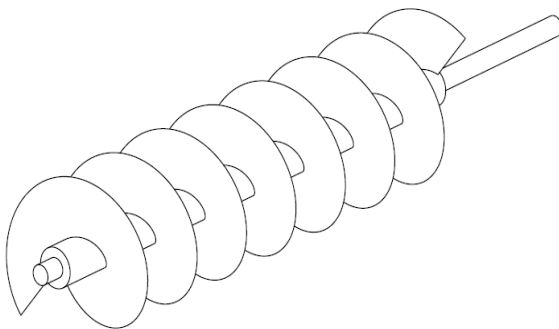

Fig- 5: Spiral Auger

C. Servo Motor

A servomotor is a rotary actuator or linear actuator that allows for precise control of angular or linear position, velocity and acceleration. It consists of a suitable motor coupled to a sensor for position feedback. It also requires a relatively sophisticated controller, often a dedicated module designed specifically for use with servomotors. Servomotors are not a specific class of motor, although the term *servomotor* is often used to refer to a motor suitable for use in a closed-loop control system. Servomotors are used in this system for rotating platform to generate different patterns of Chakali as well as cutter is controlled through servomotor to cut Chakali.

D. Induction Motor

An induction motor or asynchronous motor is an AC electric motor in which the electric current in the rotor needed to produce torque is obtained by electromagnetic induction from the magnetic field of the stator winding. An induction motor can therefore be made without electrical connections to the rotor. In this system it is used to drive shaft of spiral auger, which is used to squeeze the dough. In this system we are using 1HP, 100 rpm motor.

E. Variable Frequency Drive (VFD)

A Variable Frequency Drive (VFD) is a type of motor controller that drives an electric motor by varying the frequency and voltage supplied to the electric motor. Frequency is directly related to the motor's speed. In other words, the faster the frequency, the faster the RPMs go. If an application does not require an electric motor to run at full speed, the VFD can be used to ramp down the frequency and voltage to meet the requirements of the electric motor's load. As the application's motor speed requirements change, the VFD can simply turn up or down the motor speed to meet the speed requirement. It reduces energy consumption and energy costs, increases production through tighter process control. Moreover, it extends equipment life and reduces maintenance. In this system, VFD is used to control induction motor.

F. Other components

There are other components used in system like level sensor, HMI, LCD display, encoder, wires, switches, etc.

3.2 System Control Component

Programmable Logic Controller (PLC)

A Programmable Logic Controller (PLC) is an industrial computer control system that continuously monitors the state of input devices and makes decisions based upon a custom program to control the state of output devices. Almost any production line, machine function, or process can be greatly enhanced using this type of control system. However, the biggest benefit in using a PLC is the ability to change and replicate the operation or process while collecting and communicating vital information. Another advantage of a PLC system is that it is modular. That is, you can mix and match the types of Input and Output devices to best suit your application. As shown in Fig -1, PLC is main controller which controls servo motors, induction motor, level sensor, LCD panel and control panel i.e. HMI. In this system we are using Delta DVP12SA211T PLC. It is SA2 series slim type PLC which offers larger program capacity

and executing efficiency, offering 100 kHz high-speed output and counting functions. It is expandable with DVP-S series left-side and right-side extension modules.

3.3 Programming Used

A. Ladder Programming

Ladder logic is main programmable method used for PLCs. It is also known as “relay logic”. The relay contacts used in relay controlled systems are represented using ladder logic. It mimics circuit diagrams with “rungs” of logic read left to right. Each rung represents a specific action controlled by the PLC, starting with an input or series of inputs (contacts) that result in an output (coil). Because of its visual nature, Ladder Logic can be easier to implement than many other programming languages. The decision to use the relay logic diagrams was a strategic one. Through this programming (as shown in Fig- 6) different patterns of Chakali is generated, induction motor is controlled, cutter is programmed to cut chakalies after some period of time and level sensor is programmed to give feedback whether hopper is empty or not.

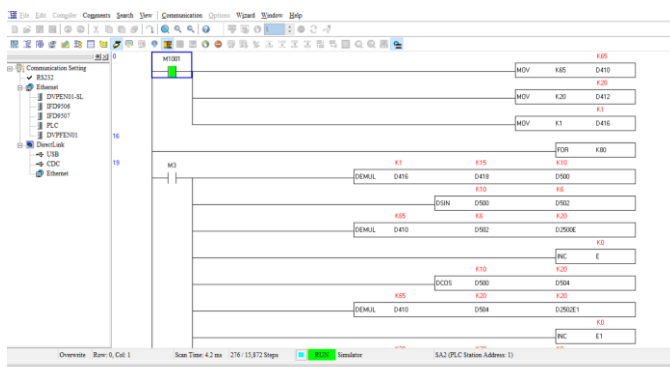

Fig- 6: Ladder Programming

B. HMI Programming

Human machine interface (HMI) software is programming that gives operators a way to manage machine command panels. Interaction is through a graphical user interface (GUI) that facilitates information exchange and communication between two types of HMI — supervisory and machine level. Such software has high upfront cost, but is inexpensive long-term thanks to the way it reduces redundancies. Even lower-tech applications (in which most machine interaction is via switches and pushbuttons) entry-level HMI offerings are making inroads — as they often reduce interface-part count and simplify controls. More sophisticated applications benefit in a different way. In this

system (as shown in Fig- 7), HMI is used as control panel which perform operations like selection of design, starting pallet assembly, illustrating indication of hopper’s fulfillment.

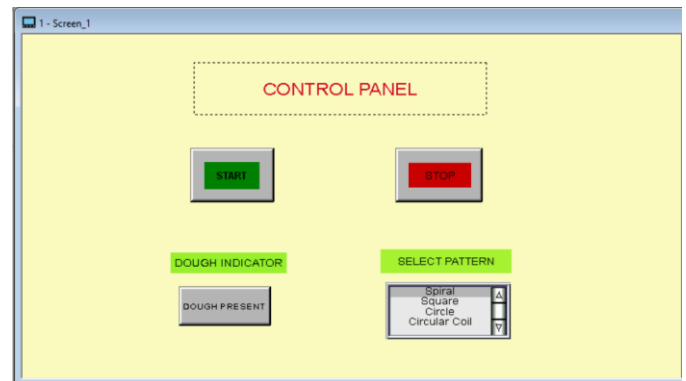

Fig- 7: Control panel of system

4. CONCLUSIONS

The main objective of this paper was to study the process automation using PLC in Chakali manufacturing, which was successfully implemented. Most manufacturing companies are looking for automation competent engineers with basic aptitude towards and ability to work on varied brand of PLCs, Drives, Motors and HMI. High level of technical skill is required to keep it going in operations and maintenance. Automation of Chakali manufacturing plant enabled to complete a batch in almost half the time initially required, so that the output of Chakali unit is increased, the consumptions of dough and electric energy is reduced, less attendance is needed, and the productivity of the workers and the conditions of manufacture are improved. Moreover, hygiene is also increased and less labor power is required which ultimately increase the profit. This work can be implemented in small scale industries.

5. ACKNOWLEDGEMENT

We would like to express our heartfelt gratitude to our project coordinator and Head of Department of Electronics and Telecommunication Engineering Prof. Shrinivas Patil for his guidance, invaluable support and encouragement throughout the project. We would also like to thank our sponsorer and co-guide Mr. Girish Bartake providing us this opportunity to work on a project and fully sponsoring this project. We want to extend sincere thanks to him for his guidance and constant supervision as well as for providing necessary information regarding the project. We would also like to express our gratitude towards our parents and our

college for their kind co-operation and encouragement which helped us in completion of this project. Our acknowledge and appreciations also go to our colleagues in developing the project and people who have willingly helped us out with their abilities.

6. REFERENCES

- [1] A. Solanki, V. Solanki, D. Shah: "Design & Development Of Automatic Fastfood Machine" from International Journal of Mechanical, ISSN 2278 – 0149, Vol. 3, No. 3, July, 2014
- [2] "Assembly automation groups with artificial intelligence", Industrial Automation March 2011.
- [3] Bosch Rexroth Group, "Mechatronics System", SEARCH FEB2011.
- [4] Kelvin Erickson, "A Programmable logic controllers", IEEE potentials, pp.14- 17, March-1996
- [5] John Hackworth & Frederick Hackworth, Programmable Logic Controllers: Programming Methods and Applications, December-2012.