

AUTOMATIC BILLING TROLLEY

Dr P.Pavithra Roy¹, M.Jyothsna Sai Lakshmi², P.Bhavani³, V.Gangadhar⁴, S. Supriya⁵

¹Professor, Dept. of Electronics and Communication Engineering, Dhanekula Institute of Engineering and Technology, Andhra Pradesh, India

^{2,3,4,5}Bachelor of Technology, Dept. of Electronics and Communication Engineering, Dhanekula Institute of Engineering and Technology, Andhra Pradesh, India

Abstract - Automatic Billing Trolley system gives solution to reduce the shopping time at supermarkets. It takes lot of time and customer has to wait till all products get scanned to generate the bill and also need more human resource in the billing section. To tackle this problem, we have proposed a solution in which Automatic Billing Trolley. It consists of RFID tag, LCD display, all products present in the shopping mall will be tagged with RFID. Customer's required products will be put in the trolley, where its code will be detected using RFID and name of the product and cost will be displayed on the LCD. The customer can pay the bill through any one of online payment options such as Paytm, UPI, and Phone Pay etc... And also a weighing sensor is placed along with a buzzer in the trolley and a limit of weight is fixed and buzzer makes a sound. And a door is placed on the trolley soon as the product is recognised the door opens. And by using a Bluetooth module we can send a message to the mail having the cost and list of goods purchased.

Keywords: RFID tag, Trolley, LCD, Bluetooth, camera module, motor gear, GSM module, IR photo diode, power supply.

1. INTRODUCTION:

Throughout the 20th century our views, expectations and methods of doing work have changed drastically. Many of the Innovations and information Technologies have caused a revolution in values, knowledge and perceptions in practically all areas of human understanding. One regular task that human beings spend a considerable amount of time on is in Shopping.

The customers face the problems regarding the wastage of unnecessary time at the counters for bill. An improvement is required in the billing system to update the quality of shopping & experience to the customers. To overcome these problems stated above and to improve the existing system, we have designed an AUTOMATIC BILLING TROLLEY. This upgraded system will intend to assist shopping to the individual that will minimize their time spent in shopping

The Automatic billing trolley is equipped with Radio Frequency Identification for product identification and it also has an LCD display that informs customers about product prices and the total bill. As soon as the object is dropped into or removed from the trolley, the IR Sensor &

RFID Reader identifies the product and updates the bill. When the customer is done with shopping, he can just press the 'RESET' switch and the details will be sent to the LCD display and then to the MASTER PC and the customers will have to just pay the amount and leave the mall.

1.1 LITERATURE SURVEY

In paper [1] has discussed the current problem of waiting in a long queue during billing process and there is a huge amount of rush at the time of festival to avoid this problem author proposed smart shopping cart. It consists of LCD, barcode technique, microprocessor, and Bluetooth. In paper [2] author proposed the project successfully demonstrated the possibility of using WSN for developing of smart shopping system which automates the entire billing procedure. The system which developed is highly reliable, fair and cost effective. It is reliable and fair because of the effectiveness of WSN combined with a highly reliable image processing technique. [3] This paper is expected to present the use of the Internet of Things in the Intelligent Interactive Super Market Framework administration and clients shopping, to illuminate a portion of the downsides in the past the general store. Acknowledging Intelligent Interactive Super Market Framework, while sparing the client and shopping center administration power part of time, and from the source to guarantee quick and advantageous portable installment work, most likely make cutting edge life more helpful

1.2 PROPOSED SYSTEM

As user puts items in the trolley the RFID reader reads the RFID tags and sends a signal to the ARDUINO UNO Controller and the motor door opens then the trolley takes the product into it. Then the name of the product, cost will be displayed on the LCD board. If the trolley is full then the buzzer makes a sound. In this billing trolley we can add the products and also delete the products by delete option through RFID cards. And after that the bill will be generated the customer can pay the bill through any one of the online payment options such as Paytm, UPI, Phone Pay etc. The customer can receive message about total cost. And the link also given below to pay money through online. We are using a camera module for security purposes.

Reduce the wastage of time:

Nowadays people are using shopping malls more for getting their essential needs and goods. In fig.1.8 in shopping malls we have large queues for the billing process and it consumes more time .So we are using an RFID scanner in the trolley which generates bills by reading the RFID tags of the products

Automatic bill generating:

After scanning the RFID tags the bill is generated and displayed on the trolley screen and so we can add any product into the trolley and delete any product in the trolley by using an add and delete switch and according to the products present in the trolley the bill is generated and the person can pay the bill either by using UPI are by means of cash

in the trolley the RFID reader reads the RFID tag placed on the product.



Fig 3: RFID Reader

LCD Display: We are using 16x2 LCD display. If the information matches as in the microcontroller then the cost, name and quantity of the product will be displayed on the LCD.



Fig 4: LCD Display

GSM MODULE (SIM 900A): It is used to interact with GSM network using a computer. GSM module only understands AT (Attention) commands. We use SIM900 GSM Module-the module supports communication in 900MHz band.

In our project, our GSM module requires a 12 volts input. So we feed it using a 12V, 1A DC power supply.

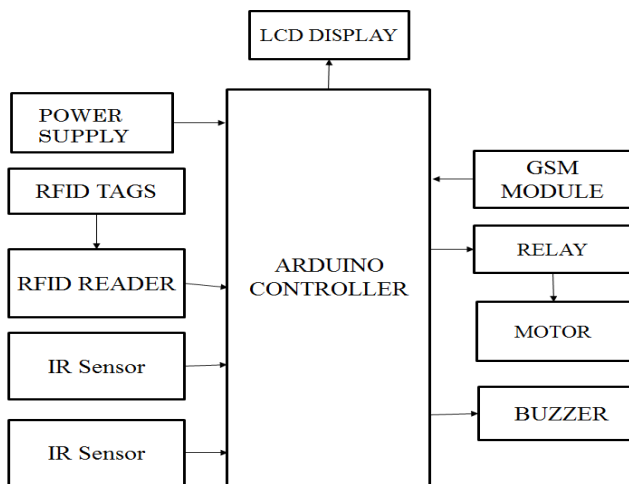

Fig -1: Block diagram of the cart

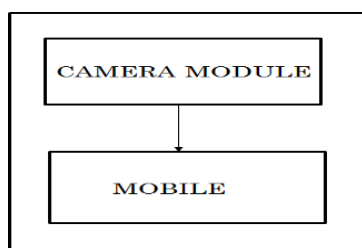

Fig 2: Block diagram of camera module interfacing

The proposed system is as shown in figure 1. This Automatic Billing trolley has the application such as Automatic billing at shopping mall and helps to owners.

Power supply: First initialize the power of the module using battery i.e. 12v, then it is ready to use for the customer.

RFID Reader: Radio frequency identification is unique for every product [4]. It can read 40 tags and it does not require line of sight to read the products. As soon as the product falls

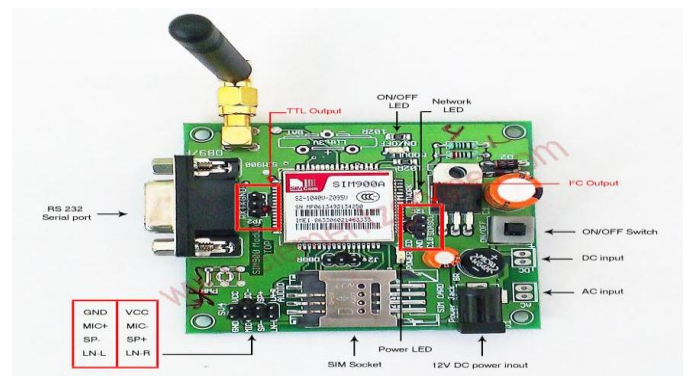

Fig 5:GSM Module

IR SENSOR:The concept of infrared sensor circuit is one of the basic a popular sensor module in an electronic device this sensor is analogous to human’s visionary senses, which can be used to detect obstacles and it is one of the common application in real time



Fig 6: IR sensor

MOTOR DRIVER:The Motor Driver is a module for motors that allows you to control the working speed and direction of two motors simultaneously. L293D is a 16 Pin Motor Driver IC. This is designed to provide bidirectional drive currents at voltages from 5 V to 36 V.



Fig 7: Motor drivers

RELAY:

Relays are switches that open and close circuits electromechanically or electronically. Relays control one electrical circuit by opening and closing contacts in another circuit. As relay diagrams show, when a relay contact is normally open (NO), there is an open contact when the relay is not energized[5]



Fig 8: Relay

V380 CAMERA MODULE:

V380 Camera is a kind of Wi-Fi camera product integrated with remote configuration camera, remote viewing, remote playback. It is a new generation of intelligent technology application, can conveniently realize the remote video information and management. It is Roughly divided into three kinds of cameras on the website: V380 Home Security Camera, V380 Outdoor IP Camera, V380 Bulb Light Camera.

This camera module is used in our project for the security purpose.



Fig 9: Camera module

FLOW CHART:

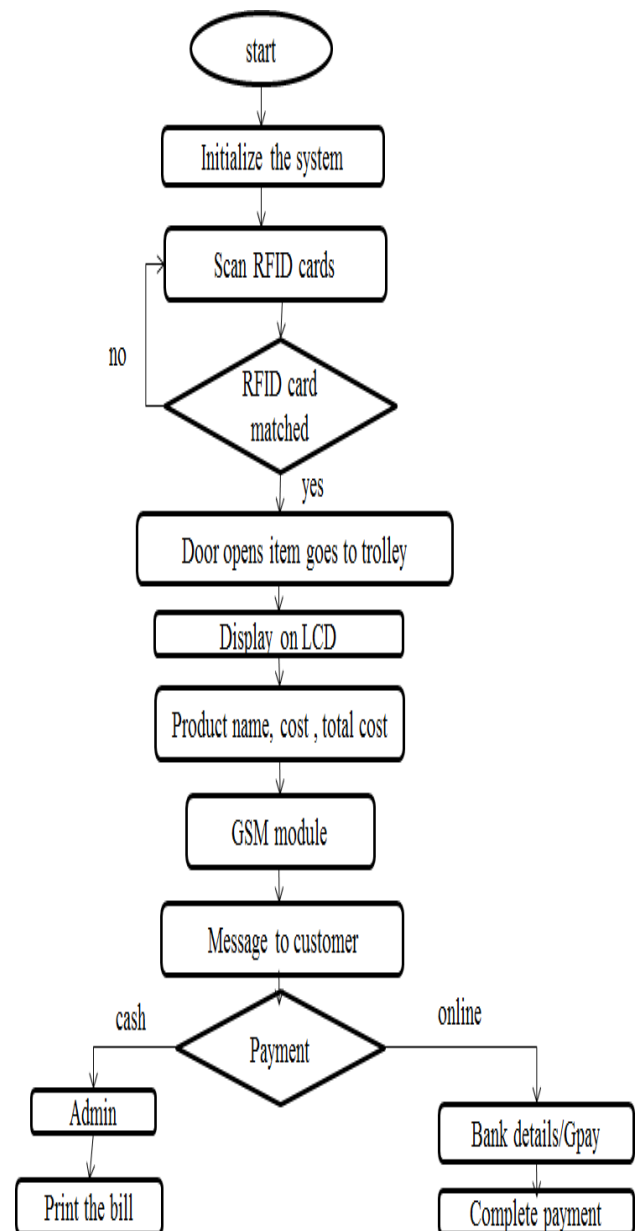

Fig 10: Flow chart of the project

EXPERIMENTAL RESULTS:



Fig 11: Complete project



Fig 12: Output from LCD Display when RFID reads the RFID Cards



Fig 13: Output from LCD Display when the trolley is full or RFID is not matche

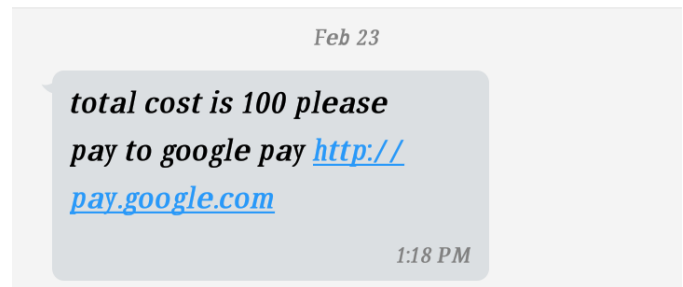

Fig 14. GSM Module & Message sent to the customer mobile

CONCLUSIONS

Using PID (product identification), customers will not have to wait near cash counters for their bill payment. Customers can pay their bill through credit/debit cards as well as through online payment. The system proposed is highly dependable, authentic, trustworthy and time-effective. There will be reduction in salary amount given to employees, reduction in theft. Also, the system is very time-efficient and as we are using a camera module we can also see that no theft happens

Hence, by using automatic billing trolley the shopping can be made easy for the customers as well low cost and does not need any special training

REFERENCES

- [1] Dhavale Shraddha D, DhokaneTupti et al. "IOT Based Intelligent Trolley for Shopping Mall", International Journal of Engineering Development and Research, Vol.4, Issue 2, pp 1-3, 2016.
- [2] Vidya Palve, Arpita Mahale et al. "Smart Trolley in Mega Mall", International journal of advance research in science and engineering, Vol.6, Issue no.2, February 2017
- [3] Arjoo Pathan, Rujuta Kokate, et al. "Digital India: IoT Based Intelligent Interactive Super Market Framework for Shopping Mall", science publication group. Vol.1, pp 1-5, December 2016.
- [4] Roy Want Intel Research, "An Introduction to RFID Technology" Published by the IEEE CS and IEEE ComSoc, IEEE 2006
- [5] file:///C:/Users/DELL/Desktop/New%20folder/BEE012%20SOLID%20STATE%20RELAYS.pdf