

“Solar Powered Automated Siren using Arduino Uno”

Shivakumar I¹, Kishor Kumar Markal², Nitesh M³, Avinash B M⁴, Hanumanthappa⁵

¹Assistant Professor, ^{2,3,4,5}Students

¹⁻⁵Dept. of Electrical and Electronics Engineering, R Y M Engineering College, Ballari, Karnataka-583104

Abstract – The foremost intention of this project is to run Siren for certain intervals of time using an Arduino. An Arduino is an open-source platform consists of both a physical programmable circuit board and a piece of software. A user can program their siren to activate during certain system events. Sirens are loud noise-making devices that connect with a solar panel directly. This proposed system also provides a backup for biometric unit by usage of solar energy. This system overcomes human interference for switching siren for required intervals of time and provides backup for biometric unit when main supply fails.

1. INTRODUCTION

Rising fossil fuels and burning fuel such as coal, global warming and severe weather condition have compelled many nations to look for alternative sources to reduce reliance on fossil based fuels. Solar energy is one of the most promising renewable sources that is currently been used worldwide to contribute for meeting rising demands. Solar energy is clean abundant and easily harnessed form of energy. Solar energy, although unreliable, is becoming more and more popular with advancement in technology and decreasing in cost with modern control systems. These are becoming increasingly reliable source of energy and in some years it might replace conventional sources completely. Generally batteries are used to store solar power for later use. A solar charge controller manages the power going into the battery bank from the solar panels. A PWM charge controller stands for pulse width modulation which acts as intelligent switch between battery and solar panel that controls the voltage and current flowing into the battery.

An Arduino is actually a micro controller based kit which is used to ride the siren; it is basically used in communications and in controlling or operating many devices. Arduino software is compatible with all type of operating systems, and it is easy to use for beginners, it is less expensive and we can develop Arduino based project which can be completely stand alone or projects which involve direct communication with software loaded in the computer. Arduino can also be used for many applications such as actuators, operating relay circuits etc.

Sirens are very useful for alerting students and teachers in schools and colleges. The sound output from an

ordinary siren is typically 85 Db. The siren generally requires 12V DC for full activation. Along with Siren, biometric device is a security identification and authentication device which enhances security amongst the workers and safeguards the working environment along with protecting college’s valuable data.

2. PROBLEM DEFINITION

In most of the situations siren needs to be operated with the help of humans which requires additional operator to drive it. The siren needs to be operated on regular basis for particular intervals of time and this needs continuous monitoring which requires human efforts. This involvement of human action may lead to some errors so in order to overcome this human effort of operating the Siren manually; we are implementing the Arduino programming code.

The biometric units usage is only possible when main supply is available. This is overcome by providing a back for the biometric unit through solar powered battery. This provides continuous availability of biometric unit for usage.

3. BLOCK DIAGRAM

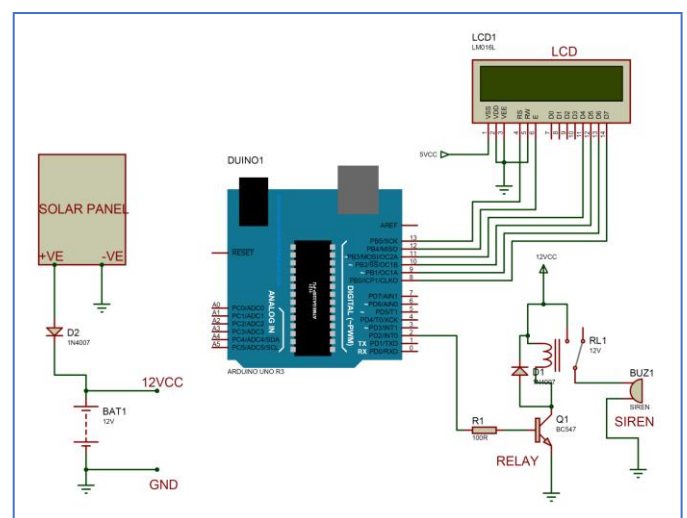

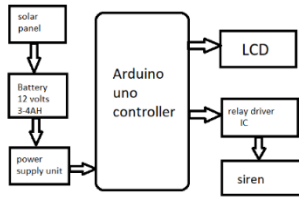

The methodology used in the system is divided into three stages of operation

Input stage – Generation of power

Intermediate stage – Software based inter connected system

Output stage – Blowing of Siren and backup for Biometric unit.

INPUT STAGE:

- The input stage involves generation of power which is done through the solar photovoltaic cells which uses sun as source of energy for generation of power. The generated power is connected to charge controller which is further fed to battery to empower the further operation of the system.

INTERMEDIATE STAGE:

- The intermediate stage here involves Arduino based microcontroller circuit which utilises the programming code. This program monitors switching operation of relay based on precise intervals of time, the siren interconnected to relay operates based on switching characteristics of relay circuit

OUTPUT STAGE:

- The final stage of the system involves siren which is empowered through programming circuit and the biometric unit is supplied through backup from solar power generated.

4. COMPONENTS REQUIRED

- Arduino Uno Controller
- Regulated Power Supply Unit
- 16x2 LCD
- Battery
- Relay driver
- Siren

▪ **Solar panel (PV-cell):**

Solar panels harness the sun's energy in the form of light and convert the energy into electricity. Although the average consumer might associate solar panels with residential rooftop assemblies, solar panels are available for a wide range of applications, including powering individual gadgets, electronic devices and vehicle batteries. The smallest unit of a solar panel is the solar cell, also called a photovoltaic, or PV cell; it's the individual PV cell that turns sunlight into electricity. Individual cells arranged in a group are called a "module" or panel; a collection of two or more panels is called an array. According to the National Renewable Energy holds approximately 40 cells and the average residential array consists of 10 to 20 panels.

▪ **Battery:**

An electric battery is a device consisting of one or more electrochemical cells with external connections provided to power electrical devices such as flashlights, smart phones, and electric cars. When a battery is supplying electric power, its positive terminal is the cathode and its negative terminal is the anode. The terminal marked negative is the source of electrons that when connected to an external circuit will flow and deliver energy to an external device. When a battery is connected to an external circuit, electrolytes are able to move as ions within, allowing the chemical reactions to be completed at the separate terminals and so deliver energy to the external circuit. It is the movement of those ions within the battery which allows current to flow out of the battery to perform work. Historically the term "battery" specifically referred to a device composed of multiple cells however the usage has evolved additionally to include devices composed of a single cell. The battery used is 12v dc battery which stores the charge and operates the system when required.

• **Arduino**

Arduino/Genuino Uno is a microcontroller board based on the ATmega328P. It has 14 digital input/output pins (of which 6 can be used as PWM outputs), 6 analogy inputs, a 16 MHz quartz crystal, a USB connection, a power jack, an ICSP header and a reset button. It contains everything needed to support the microcontroller; simply connect it to a computer with a USB cable or power it with a AC-to-DC adapter or battery to get started. You can tinker with your UNO without working too much about doing something wrong, worst case scenario you can replace the chip for a few dollars and start over again.

"Uno" means one in Italian and was chosen to mark the release of Arduino Software (IDE) 1.0. The Uno board and version 1.0 of Arduino Software (IDE) were the reference versions of Arduino, now evolved to newer releases. The Uno board is the first in a series of USB Arduino boards, and the reference model for the Arduino platform; for an

extensive list of current, past or outdated boards see the Arduino index of boards.

- **LCD Display:**

LCD (Liquid Crystal Display) screen is an electronic display module and find a wide range of applications. A 16x2 LCD display is very basic module and is very commonly used in various devices and circuits. Here display is used to indicate the condition of soil either it is dry or wet and also the status of pump when it is OFF or ON.

- **Relay Driver:**

A relay is an electro-magnetic switch which is useful to use a low voltage circuit to switch on and off a load connected to the mains supply. Here relay driver is used to switch ON and OFF the pump on the demand of field. The relay driver is controlled by arduino.

- **SIREN:**

Power Source	DC/Battery
Siren Range	6 to 24 VDC
Usage	Electronic, Industrial, Security, Door.
Sound Level (dB)	115 dB to 125 dB
Tone	Single Tone

5. SOFTWARE

Arduino Software (IDE) Compiler The Arduino Integrated Development Environment - or Arduino Software (IDE) - contains a text editor for writing code, a message area, a text console, a toolbar with buttons for common functions and a series of menus. It connects to the Arduino and Genuino hardware to upload programs and communicate with them.

CONCLUSION

The Arduino based automatic siren and backup for biometric unit is designed and constructed in current work. The conclusion of the project is summarised as, the Arduino interfaced with siren system is accurate and reliable and it results in precise operation of the siren on proposed interval of times without human effort. This system can be employed in schools, colleges and industries for a time based alarming system. This project also offers new and advanced idea to help the people by enabling continuous operation of the biometric unit by backing up through solar panel.

REFERENCES

1. "Let US C" By YeshvanthKanethkar, Publisher: ones & Bartlett Publishers.
2. <http://www.engineersgarage.com/8051-microcontroller>
3. <http://en.wikipedia.org/wiki/Microcontroller>
4. Sheenu Choudhary, Shrikant and Priyanka Sharma, Automatic college bell system: IJSRM, Vol(02), Issue(3), 2014
5. Ronal, L & Ronald E, W. 1996. Implimentation of Solar Thermal Energy
6. Xu, W 2009. china Solar Building Application Development Study 2009
7. Anand Nayyar & Er. Vikram puri, "A review of Arduino's board's, Lilypad's and Arduino Shields", International conference Computing for Sustaineble Global Development (INDIACom), Electronics ISBN:9789-3805-4421-2, Pages 1485-1492, 2016