

# A Review on Fuel Injection System

Shreyansi Gupta<sup>1</sup>, Anuj Patidar<sup>2</sup>

<sup>1</sup>Chemical, MIT-WPU, Pune, India

<sup>2</sup>CSE, MIT-WPU, Pune, India

\*\*\*

**Abstract**-As the world population is increasing day by day, the requirements of people are also increasing. New inventions and researches are conducted to make life more comfortable. As advanced technologies are coming up, the environmental problems cannot be ignored. There is a need of sustainable environment for us, as well as the future generation. Keeping in mind these changes, invention of electronic fuel injection (EFI) system from carburetors has proved very beneficial. This paper gives a review on the advancement of this system over the span of 20 years and explains the need for proceeding fuel injection system for better fuel efficiency, fuel management and less carbon emissions.

**Keywords**-electronic fuel injection system, fuel efficiency, carbon emissions.

## 1)Introduction-

In today's hi-tech world, where everything is being made accessible for human beings, the shift of carburetors to fuel injection engine has made some major changes, in engines around us and thus the vehicles. Let it be cars which use indirect fuel injection system or bikes which use direct fuel injection system or the trains which use rail direct fuel injection system, all kinds of vehicles are now accustoming fuel injection system. The major reason for this switch is to lower carbon emissions and also to get better efficiency, which was not possible with carburetors.

Fig 1: fuel injector [1]

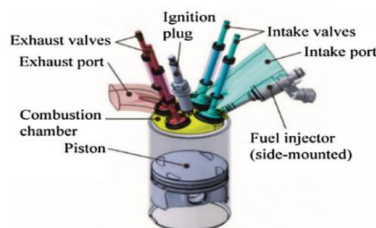

	Carburetors	Electronic fuel injection system
Performance	Good	Better
Emission friendly	Poor	Excellent
Fuel Distribution	Fair	Excellent
Initial cost	Low	High
Long term cost	High	Low

Table 1: Comparison between carburetors and EFI system [2]

Corporate Average refers to the sales-volume weighted average for every auto manufacturer. The norms are applicable for petrol, diesel, LPG and CNG passenger vehicles. CAFE regulations in India came into force from April 1, 2017. Under this, average corporate CO<sub>2</sub> emission must be less than 130 gm per km till 2022 and below 113 gm per km thereafter.

A study has found that the adoption of CAFE standards if supported together by government incentives, would accelerate the Electric Vehicle Market [3]. That's how the fuel injection system comes into the picture and can be benefitted. Fuel injection provides a continuously adjustable air/fuel mixture that increases with engine speed, load, throttle position, air temperature, coolant temperature, and other operating conditions. This allows EFI to provide an Air/Fuel (A/F) ratio that minimizes emissions while maximizing fuel economy. From the previous research, we came to know that along with fuel injection the use of turbochargers and superchargers has also come into the play as they force extra compressed air to the combustion chamber to give better power output and fuel efficiency [4]. Between the turbocharger and supercharger, turbochargers are preferred because superchargers are mechanically driven and are directly connected to the engine. The use of electronic engine systems has helped in fuel metering and injection timing control and proved very efficient as compared to mechanical injection which can be troublesome and so are unpopular among consumers [5].

A study conducted said that by increasing fuel injection pressure pollution level reduce due to complete combustion [6]. Thus, the carbon discharges can be reduced. The main types of fuel injection system are-

- Single-point injection
- Multipoint fuel injection
- Direct-injection

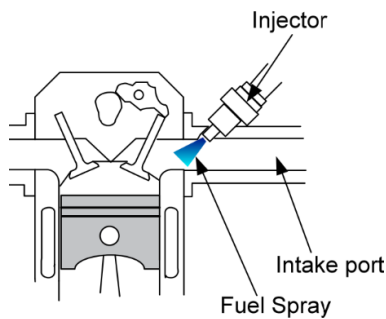

Fig 2: Single-point injection [7]

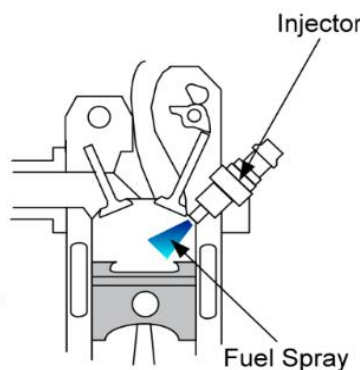

Fig 3: direct fuel injection [7]

Out of these, the direct-injection method is the most competent option. Talking about the engine type there are diesel engines, petrol engines, and gasoline engines. Keeping in mind the requirements of present day the best combination would be a diesel direct injection system.

Though there are several advantages of fuel injection system, some shortcomings which can be listed are – first the entire system is fairly expensive and also its maintenance adds to the cost, second in case of electronic control unit (ECU) failure the whole system will shut down. Therefore, assessing the applicability of new fuel systems is essential and highly practical. In this paper apart from basic data collection attention is paid to market standards of fuel injection system and also the future aspects of it.

## 2) Components of fuel injection system and basic working-

### List of Main Components in Fuel Injection system-

- Fuel tank
- Fuel Feed pump
- Injection pump
- Governors
- Fuel Injector
- Nozzle

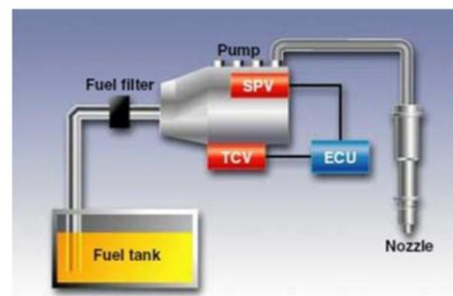

Fig 4: Components of FI System [8]

The fuel injector is comprised of the following components-

- Needle valve
- Compression spring
- Nozzle
- Injector body

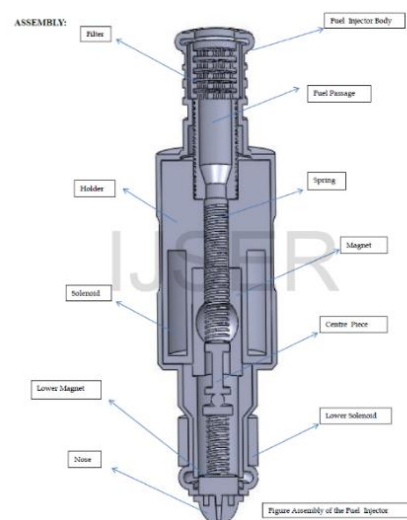

Fig 5: inside fuel injector [9]

### 3) Concept of Fuel injection-

It is the introduction of fuel to the combustion chamber by means of an injector. The fuel is injected into the chamber where it mixes with air, the ratio of fuel to air should be 14.7:1. This is a very crucial step as there should be proper mixing of fuel and air so that the combustion proceeds accurately. After this, the normal cycle of the engine continues. Electronic fuel injection systems were developed that relied on various sensors and controllers. When working together, these electronic components can sense variations and the main system computes the appropriate amount of fuel needed to achieve better engine performance based on a stored "map" of optimal settings for given requirements [10]. This characteristic was absent in mechanical fuel injectors, which gave rise to the electronic fuel injection system. Also fuel injectors do a dual job, they supply fuel as well as do fuel metering.

### 4) Market analysis of fuel injection system-

As the fuel economy standards are rising the market for fuel injection systems is also progressing. In 2015, the global automotive fuel injection systems market is estimated to be at USD 54.72 Billion, which would reach USD 73.62 Billion by 2020, growing at a CAGR of 6.11%. The demand in the Asia-Pacific region is advancing at a good pace, given the increasing automotive production in these regions. Growing purchasing power, demand for high fuel-efficient vehicles, and enforcement of rigorous emission norms in developing nations such as China, Thailand, and India have increased demand for the fuel injection system [11].

The market value of two-wheeler fuel injection systems is projected to grow at a CAGR of 6.76% to reach \$ 8.6 Billion by 2019[11].

Fuel Injection System Market Revenue, By Geography (%)



Source : IndustryARC Analysis, Expert Insights

Global Two-Wheeler Fuel Injection Systems Market Size, by Technology, 2014 vs 2019 ('000 Units)

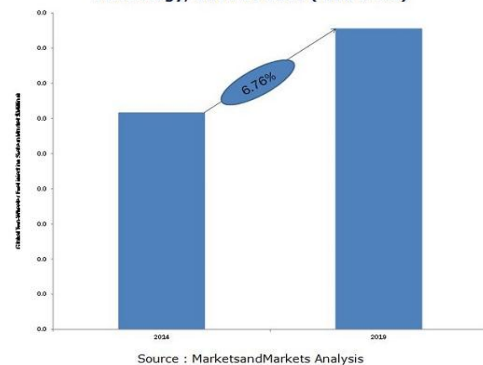

Source : MarketsandMarkets Analysis

Global Fuel Injection Market Size, by Technology, 2015 vs. 2020 (USD Million)

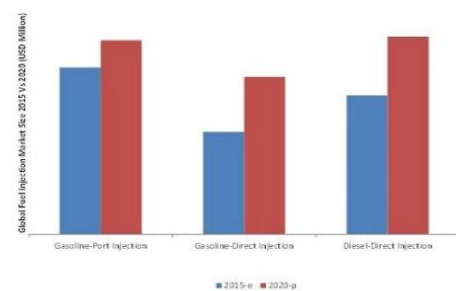

Source : MNM Analysis

All these reports show that the global market is rising rapidly for fuel injection system and will notably increase with the coming advancements and technologies and the necessity of people.

### Conclusion-

With more strict emission regulations to be coming in the near future more improvements for better efficiency will be accomplished. Techniques such as common-rail system, hydraulically actuated electronically controlled unit injector (HEUI), intelligent accuracy refinement technology (I-ART), have come into existence which was not possible 20 years earlier. Injectors with more high pressure which can give better fuel consumption will be needed. These systems will increase the accuracy to next level which will be needed for the forthcoming generation.

### Acknowledgment-

Valuable guidance and support from Pratiksha Kale from MIT-WPU, Chemical Department are gratefully acknowledged.

## References-

- [1] Shijin Shuai<sup>1</sup>, Xiao Ma<sup>1</sup>, Yanfei Li<sup>1</sup>, Yunliang Qi<sup>1</sup>, Hongming Xu<sup>1</sup>, "Recent Progress in Automotive Gasoline Direct Injection Engine Technology" Automotive Innovation (2018) 1:95-113  
<https://doi.org/10.1007/s42154-018-0020-1>
- [2] S. S Thipse, "Textbook of Internal combustion engines second edition"
- [3] Parvatha Vardhini C, "The Hindu Business Line" published on June 17, 2019
- [4] "Journal of Mechanical Engineering Research & Development (JMWED)"  
DOI: <http://doi.org/10.26480/jmerd.01.2019.01.09>
- [5] Faiz, Asif, Weaver, Christopher S., Walsh, Michael P., Gautam, Surhid P. (1996). "Air Pollution from Motor Vehicles, Standards and Technologies for Controlling Emissions" The World Bank. p. 133. ISBN 9780821334447. Retrieved 26 August 2017.
- [6] "Certified International Journal of Engineering and Innovative Technology (IJEIT) Volume 2"  
ISSN: 2277-3754 ISO 9001:2008, Issue 4, October 2012
- [7] \*Mustafa Bahattin Çelik, \*\*Bülent Özdalyan "Gasoline direct injection", \*Karabuk University, Engineering Faculty, \*\*Karabuk University, Technology Faculty, Turkey
- [8] "Journal of Mechanical Engineering Research & Development (JMWED)" DOI:  
<http://doi.org/10.26480/jmerd.01.2019.01.09>
- [9] T K S Sai Krishna, Kasanagottu Shouri, Repala Deepak Kumar "Design and Analysis of Electronic Fuel Injector of Diesel Engine", "International Journal of Scientific & Engineering Research Volume 4", Issue 10, October-2013, ISSN 2229-5518
- [10] Faiz, Asif; Weaver, Christopher S.; Walsh, Michael P.; Gautam, Surhid P. (1996). "Air Pollution from Motor Vehicles, Standards and Technologies for Controlling Emissions" The World Bank. p. 133. ISBN 9780821334447. Retrieved 26 August 2017.
- [11] "Automotive Fuel Injection Systems Market Technology" (Port Fuel, Gasoline Direct, & Direct Diesel), Fuel Type (Gasoline & Diesel), Region (APAC, Europe, North America, & RoW), Vehicle Type (PC, LCV, & HCV), and by Component - Trends & Forecast to 2020