

INNOVATION AND EVOLUTION OF A ROBOT TO UNCLOG SEWAGE CHANNELS

Ms.A.P.Nithiya Priya ¹, Nivedha.G ², Poongulali.R ³, Rekha.L ⁴

¹Assistant Professor, Department of Electronics and Communication Engineering, Adhiyamaan College of Engineering, Krishnagiri district, Tamilnadu, India

²⁻⁴UG Scholars, Department of Electronics and Communication Engineering, Adhiyamaan College of Engineering, Krishnagiri district, Tamilnadu, India

¹nithyapriyadpi@gmail.com, ²nivedhag2406@gmail.com, ³poongulali22052000@gmail.com, ⁴rekhalingappa321@gmail.com

Abstract: Robots are replacing humans rapidly in every industry. Even today sewers are cleaned by the people with the assistance of buckets and shovels. Impurities in drainage water can be only like empty bottles, polythene bags, papers, etc. This robot can be able to clean the wastes which are all present in the drainage. The mechanism is placed across an open drain floating wastes and it is raised by lifters which are attached to the conveyor. When the motor runs the conveyor starts to move upward and the waste materials are lifted up by the lifter teeth and stored in storage or collecting bin. Once the collecting bin is full, it intimates its level to the User. This all is monitored, controlled and moves by using a Node MCU module that can move by any mobile supporting Wi-Fi. And this forms an efficient and easy way of cleaning the drainage system and preventing the blockage.

Keywords: Manual scavenging, Blockage in the drainage, Special conveyor system, Node MCU.

I INTRODUCTION

Water is being used very fast in today. The significance of water is mainly used for cooking, cleaning and drinking in our lifestyle. The water used in the factory and the house comes from the drains and reaches in the rivers, in the ponds and in the oceans. In which more solid ingredients (polythene, bottles) along with water also reaches. We have built an automated drain cleaning machine with the main purpose of removing these solid materials from drains. This machine can be established at any point of drain very easily. It has been arranged in such a way that it lets water spill through it but gathers all the solid substances and gives a set in the dustbin. This device is able to do cleaning and moving operation together on the drains/gutters.

The Drainage water cleaner system is used to scrub wastes from water like polythene, bottles etc. available in water. This can be used to overcome the problem of filtration of wastes from water and it saves time and

cost that is spent on cleaning the drainage. As the industry setup increases in the environment, the water coming from industries is full of wastes like polythene, bottles, and other materials and that water mixes with the other water that is used by people and we know that that water is not good for the health of people. So, to overcome these problems we can filter the water drainage before it mixes with other water. This type of filtration of water is known as primary filtration. In this project we use a DC motor to run the system when power supply is available and the device we used to be motor, chain, driver, bucket, frame, wheel, sprocket gear, solid shaft etc. Water is a basic necessity of human and all living beings. There is a lot of water on earth that is not best suited for human use. The impurities available in water can cause dangerous diseases. Waste water is defined as the flow of used water from homes, business industries, commercial activities and institutions which are to be treated by plants by a carefully designed and engineered network of pipes.

The greatest effect of cleaning the chemical wastes can lead to respiratory diseases and it plays a role in issues for the municipality officers. Water damage is classified as three types of contaminated water. They are clean water, gray water and black water. We have built an automated drain cleaning machine with the main purpose of cleaning these hard materials from drains. This machine can be organized at any point of drain very easily. It has been designed in such a way that it lets water movement through it but gathers all the solid materials and gives a group in the dustbin. This device is able to do cleaning and in moving operation together on the drain/gutters.

Clean water is from a shattered water supply line or leaking socket. If not handled quickly, water can turn into black water or gray water, depending on length of time, temperature, and contact with surrounding contaminants. Gray water is poisoned water that causes discomfort or disorder. It is washing machine overflow

and toilet overspill with some urine, and dishwasher overflow. Black water is grossly poisoned and could cause severe disorder or death if given and avoided such as flooding from rivers or streams, water from beyond the toilet trap, water from the toilet bowl, or standing water that has begun to give importance to microbial growth. A drainage ditch is a narrow mechanism that is dug at the side of a road or field to carry away the water. Nowadays, though automatic devices plays a vital role in all industrial work in the proper destruction of sewages from industries and sewage cleaning is still a difficult task. Drainage pipes are used for the disposal of sewage and unfortunately sometimes there may be loss of people life while cleaning the blockages in the drainage tunnels. The municipality working peoples are only responsible to make sure that the sewage is clean or not. Though they clean the ditches at the side of buildings, they cannot keep wide sewages clean. The municipality workers need to get down into the sewage sludge to clean the wide sewage. It affects their health badly and also causes skin allergies.

II EXISTING SYSTEM

The present system is totally a mechanical based project. It is a stable system, kept simply kept in the sewage area to gather the wastes crossing over it. The chain and is used for conveyor motion, which has fixed fork plates to gather the impurities from the sewage. The rotation movement of the chain along with the plates will gather the floating wastes and turn off the impurities in the bin that is kept at the backside of the given system.

III PROPOSED SYSTEM

There exist open channels where sewage water can settle and this disturbs the people nearby. The moto of this project is to decrease manual cleaning of this sewage channels to decrease serious disorder problem by automatic of sewage cleaning process using android application and sensor technology to check the system.

System design consists of various sections:

- Cleaning.
- Storage unit.
- Connectivity.
- Monitoring System

IV BLOCK DIAGRAM

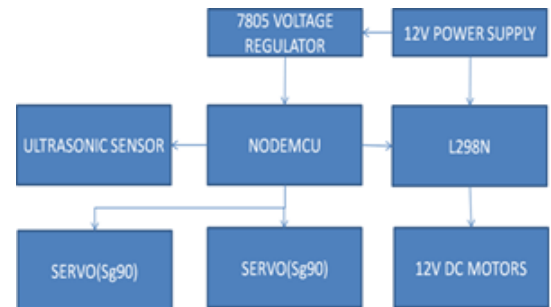

Fig 4.1: Block Diagram

V CIRCUIT DIAGRAM

The machine is placed across the drain so that only water flow through the screen, the impurities like bottles, plastic covers etc. hovering in drain are up lifted and the lifter is joined to the shaft which is driven with the help of servo motor. When motor moves the lifter it starts the circulation making with lifter to lift up impurities, further the impurities kept in a container. Then the information base of the project can be seen by using mobile app.

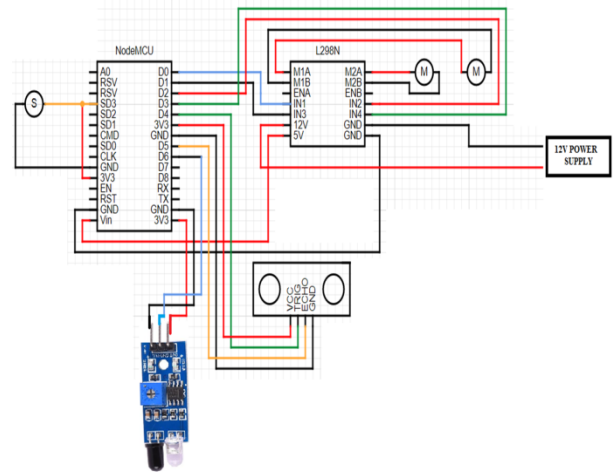

Fig. 5.1 Circuit Diagram

VI EXPERIMENTAL RESULT

It is our total working model of automatic drainage cleaning robotic system. It has of mainly 3 operations such as motion of robot with all directions i.e., forward, backward and 4sides. Then, the process of robotic arm which works like our human arm with the help of servo motor, then the lifter which gathers all the wait particle that floats over water.



Fig: 6.1 Output Figure

VII CONCLUSION

Modern process are becoming polarized. With the emergence of more and more automatic terminal services, modern services are also gradually becoming unmanned. Thus, this semi-automated drainage cleaning system helps in cleaning the drainage automatically and helps in decreasing the spread of diseases due to direct human intervention into the sewage. Since the system operation mainly depends on high level programming, it can be extended as per requirements. This system is time saving, portable, affordable, consumes less power and can be made easily available so that can use this system whenever and wherever. Considering the severe problem regarding the sewage cleaning, the advanced concept can give towards reducing the manual environmental pollution in our country. The advanced system is time-well organized and customer friendly. Less cost and labor would be required in the carry out of the system.

REFERENCES

- [1] P. Dhananchezhyan , Somashekhar S. Hiremath, M. Singaperumal, R. Ramakrishnan, "Design and Development of a Reconfigurable Type Autonomous Sewage Cleaning Mobile Manipulator", International Conference on Design and Manufacturing, IConDM 2013.
- [2] Balachandra, et.al." Automatic Drainage Water Pump Monitoring and Control System Using PLC and SCADA" International Journal of Innovative Research in Technology, Vol No- 1, 2014
- [3] Muhammed Jabir. N.K,Neetha John, Muhammed Fayas, Midhun Mohan, Mithun Sajeev, Safwan.C. N, "Wireless control of pick and place robotic arm using an android application", International Journal of Advanced Research in Electrical, Electronics and Instrumentation Engineering (An ISO 3297: 2007 Certified Organization) Vol. 4, Issue 4, April 2015.
- [4] Dr. Rajesh Kanna S.K.Ilayaperumal K. and Jaisree A.D, "Intelligent Vision Based Mobile Robot for Pipe Line Inspection and Cleaning", International Journal of Information Research and Review Vol. 03, Issue, 02, pp.1873-1877, February, 2016.
- [5] Nitin Sall, et.al., "Drain Waste Water Cleaner", Global Journal of Researches in Engineering: J General Engineering Vol No- 16, 2016.
- [6] Dr. K. Kumaresan et.al., "Automatic Sewage Cleaning Equipment", International Conference on Explorations and Innovations in Engineering and Technology, 2016
- [7] Mragank Sharma, Shahbaz Siddiqui, Archit Pawan, Srivastava, Shiwam k[5]Innovative Research in Computer and Communication Engineering, Vol No- 4, February 2016. 49