

Solar Powered Water Pump using PMSM with Energy Management for Agricultural Purpose in Rural Areas

Mohamed thahir P.A¹, Faris K.K², Sethulakshmi.S³

¹PG student, Dept of EEE, Al-Ameen Engineering College Kulappully, Kerala

²Asst Professor, Dept of EEE, Al-Ameen Engineering College Kulappully, Kerala

³Asst Professor, Dept. of EEE, Al-Ameen Engineering College Kulappully, Kerala

Abstract - this paper introduces energy-efficient solar-powered water pumps using Permanent Magnet Synchronous Motor (PMSM). This system is used for Agricultural purposes in remote areas. In remote areas power supply is difficult because long- distance transmission of electricity needs transformers and more transmission equipment that will cause higher cost. At that time we will use solar-powered water pumps in agriculture. Solar energy is the best source of power, the peak solar production time operates the water pump and stores the water in a tank. After that the power is stored using an inverter, stored power is used for domestic purposes. Using this stored water drip irrigation is done in agriculture. And also design a fast charging inverter system because the highest power coming from the solar is around 6 hours and 3 hours is used for water pumping, the balance of 3 hours is used to charge the inverter.

Key Words: Solar panel, Boost converter, VSI Controller, MPPT, PMSM, Bi-directional Boost Converter, Battery System.

1. INTRODUCTION

Many more technologies are implemented in agricultural areas like different types of water pumping methods, different farming methods based on newer technologies, etc. But these technologies are difficult to implement in remote and rural areas because of power requirements. Most of the agricultural fields and plantations are in remote areas that will contain hectares of agricultural fields and one or two houses near to that. These fields do not contain electricity because in remote areas long- distance transmission of electricity needs more transformers and more transmission equipment that will cause higher cost. Based on these facts the central government gives solar water pumps to the farmers by subsidy.

Using this solar pump we will design a technology that is Energy Efficient Solar Powered water pump using PMSM with energy management for remote areas' agricultural Purpose. With this technology, we will increment the size of the solar panel and add a storage unit. In the daytime peak power of solar energy is around 6 hours, based on this time 3 hours is utilized to work the pump balance time energy is stored using a battery system. The inverter system is based on a VSI controller. For proper pulse switching. The 3 hours of pump working the pumped water is stored in a tank and the stored water given to the plants by using drip

irrigation techniques. And the stored power in the inverter is used for domestic purposes

This paper is organized as follows: Section I presents the overall structure and related work Section II discusses the design specification of the proposed system and architecture of the system. Section III implementation of the proposed system and simulation results.

1.1 Related Work

Nather (2003) investigated the performance of solar photovoltaic water pumping systems using batteries for sprinkling and dripping irrigation systems. It has been concluded that solar photovoltaic water pumping systems can be used efficiently for water pumping in agriculture sectors. Water pumped by photovoltaic systems is significantly less expensive than water pumped by traditional grid-connected and diesel-powered pumping methods. They also discovered that solar photovoltaic water pumping systems are more efficient than other conventional irrigation systems during peak sunlight hours.

In another work, Chandratilleke and Ho (1986) experimentally studied the performance of a 1.14 kW solar photovoltaic water pumping system using an 860 W centrifugal pump. They also developed a simulation model for validating the experimental results. It was reported that the overall efficiency of the solar photovoltaic water pumping systems is 1.6 percentage, which was found to be lower due to the low energy conversion efficiencies with photovoltaic systems. The simulation results were said to be similar to the experimental results than the experimental results, with suitable deviations. They also suggest that the overall efficiency of the solar photovoltaic water pumping systems can be improved by good system design and load matching. The storage tank was introduced to improve the stability of solar photovoltaic water pumping systems.

In related work, a time-dependent solar photovoltaic water pumping systems model consisting of a photovoltaic array, a battery, a storage water tank, a DC motor, and a centrifugal pump was developed by Badescu (2003). According to reports, a storage water tank increases the pumping operation's stability. The gravitational energy of water is used to store a portion of the power supplied by the battery, demonstrating that both the battery and the water

storage tank improve the operating stability of solar photovoltaic water pumping systems.

Similarly, in Saudi Arabia, Al-Ali et al. (2001) developed an automatic solar photovoltaic source irrigation system and tested its performance. Their system consists of controller, control valves, photovoltaic panels, back up batteries and sensors. Their developed system is capable of irrigating fields at a pre-specified time, day of the week and duration. It can also automatically irrigate the field if the soil is dried below a certain moisture level. This type of automated system will optimize the quantity of water required for a particular crop and for a specified area. A similar performance investigation on solar photovoltaic water pumping systems using a helical pump for a deep well was made under the meteorological conditions of Saudi Arabia (Benghanemet al. 2013). Four different photovoltaic configurations such as 6 serial modules ã 3 parallel rows, 12 serial modules ã 2 parallel rows, 8 serial modules ã 3 parallel rows, and 6 serial modules ã 4 parallel rows were investigated in their work. Their results reported that the 8 serial modules ã 3 parallel configurations provided the optimal energy with a maximum water discharge of 22 m³/day.

1.2 Case Study

In India has approximately 58 percent of the geographical area can potentially be solar hot spots in the country with more than 5 kWh/m² /day of annual average global isolation (Ramachandra et al. 2011). Solar energy availability in India could fulfill the increasing power requirements in a decentralized, efficient and sustainable manner in the form of solar photovoltaic energy conversion systems. The performance of photovoltaic water pumping systems depends on ambient parameters such as solar intensity, ambient temperature, ambient relative humidity, and ambient wind velocity. The renewable energy water pumping technologies in India are influenced by many techno-economic factors including the financial incentive schemes provided by the central and state governments.

Irrigation is currently done with a 5 HP, 3 Phase induction motor for agricultural purposes. We will select 15 acres of remote areas in these panchayats: Vellinezy, Trikkadeer, and Chalavara in Kerala's Palakkad district for this research. Since agricultural fields are in remote areas, more transportation equipment is used, the initial expenditure in electric power for motor working is about 1.5 lakhs. Farmers can pay around 2300 rupees a month as a KSEB bill, equating to around 20,000 rupees a year in bill and meter charges. Farmers will lose 4 to 5 lakhs of rupees over the course of five years due to the KSEB bill and installation costs.

Because of these challenges, our proposed system is ideal for farmers in rural areas. A 2 HP solar panel, a PMSM motor, and an inverter unit are required for this design. The initialization cost is around 2 lakhs for the solar panel

and inverter units, and these components have a life of around 15 to 25 years. If life is increasing the cost will increase. By design, we use a drip irrigation method that will increase production. The peak solar power time the pump will work and store the water in a tank after that the power is utilized for inverter charging. The inverter power is used for domestic purposes in a remote area.

2. DESIGN SPECIFICATION OF THE PROPOSED CONVERTER

Photovoltaic (PV) generators use sunshine as fuel, which is free and available in plenty in a tropical country like India (India receives about 5000 trillions kWh of solar energy in one year [Annual Report, 2004-05]). The benefits of PV generators are as follows: ã Clean energy source with a long life ã Fixed cost of electricity for the whole life of the generator.

Applications of standalone PV systems: run water pumps for irrigation and drinking purposes, for street and domestic lighting, for air conditioning, food and medicine preservation, for battery charging for swimming pool heating systems and electrical vehicles battery unit, satellite power supply.

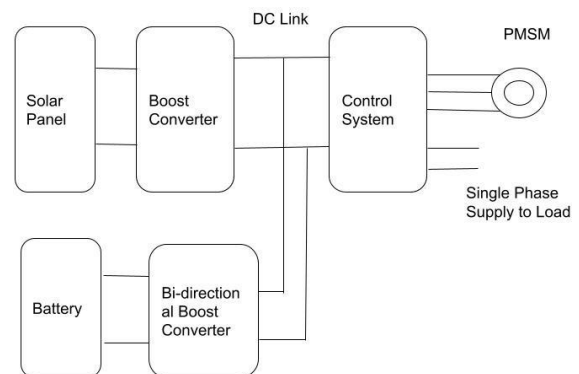

Fig. 1. Block Diagram of Proposed System

2.1. Solar Panel

In the photovoltaic field, a photovoltaic module or photovoltaic panel is basically a packaged interconnected assembly consisting of photovoltaic cells, also referred to as solar cells. An installation comprising of photovoltaic modules or panels is referred to as a photovoltaic array.

Photovoltaic cells generally demand protection from the surroundings. For reasons involving expense, multiple cells are electrically connected and then packaged in a photovoltaic module, when an assembly of these modules, which are mechanically tied together, wired, and then designed to act as a field-installable unit, at times with a glass covering and a frame and backing that is made up of metal, plastic or fibre glass, are referred to as a photovoltaic panel or just solar panel.

A suitable MPPT algorithm is to be connected between PV panel and load to operate PV system at MPP(Maximum Power Point) at all operating condition as shown in Figure 2. MPPT means to operate the PV system at maximum power point by the help of a algorithm and a converter. MPPT algorithm estimates the MPP and force the PV system to operate at that estimated MPP by the help of a converter by providing appropriate duty signal to are unavoidable

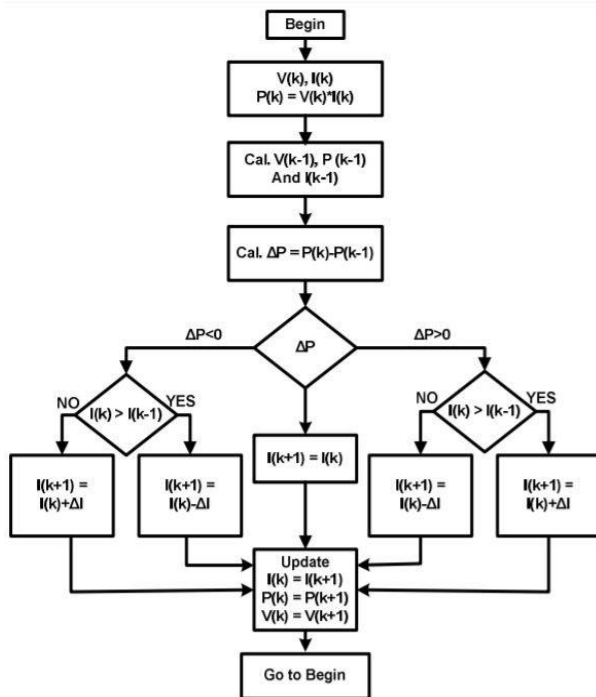

Fig. 2. Proposed MPPT algorithm

2.2. Boost Converter

The boost DC-DC converter is a power converter that steps-up the input voltage while stepping down the input current. It is a class of switched-mode power supply (SMPS) having at least one energy storage element (a capacitor, an inductor, or the two in combination) and at least two semiconductors (a diode and a switch) as shown in Figure. In BC, a series connected inductor with the input DC source helps to reduce input current ripples and a capacitor-based filter is used at the output side to eliminate the output voltage ripples. Boost DC-DC converters have various advantages. A moderate output voltage gain can be obtained (4), the switch can be easily driven concerning ground, the input current is continuous and filtering and meeting EMI requirements are simple for this converter. For the design shown in Figure, a moderate efficiency can be achieved (83-85% at full load). The output voltage is single polarity and circuitry is rather simple, thus the cost is lower, which makes it a suitable option for BEV (Battery Electric Vehicles) and PHEV (Plug-in Hybrid Electric Vehicles) power trains.

2.3. PMSM Drive

The PMSM is a rotating electric machine with a classic 3-phase stator like that of induction motor, the motor has surface-mounted permanent magnets. In this respect, the PMSM is equivalent to an induction motor, where the air gap magnetic field is produced by a permanent magnet, so the rotor magnetic field is constant. PM synchronous motors offer a number of advantages in designing modern motion control systems. The use of a permanent magnet to generate substantial air gap magnetic flux makes it possible to design highly efficient PM motors.

The speed control schemes commonly used in PMSM drive can be broadly categorized into scalar control, Vector Control (VC) or Field Oriented Control (FOC) and Direct Torque Control (DTC). In a PMSM, the dc field winding of the rotor is replaced by a permanent magnet to produce the air-gap magnetic flux. Having the magnets on the rotor, electrical losses due to field winding of the machine get reduced and the lack of field losses improves the thermal characteristics of the PM machines and its efficiency. Absence of mechanical components like brushes and slip rings makes the motor lighter, high power to weight ratio for which a higher efficiency and reliability is achieved.

PMSM is a better choice for motor control application which gives high torque to weight ratio, wide speed range and good dynamic torque control. So, researchers are more focusing on PMSM motor because of its high efficiency due to loss in the rotor is almost zero, absence of brush and slip-ring/commutator, good control over wide speed range and high power density of the machine. Now-a-days, Permanent Magnet Synchronous Motor (PMSM) is designed more powerfully with less mass and small moment of inertia. Today, PMSM is the perfect selection for speed and position control drives on machine tools and robotics because of its high power density and smaller size. Hence, the development of PMSM has not only removed the drawbacks of the induction motor and synchronous motors but also opened the new door for the researchers in the field of electrical Vehicles (EV).

2.4. Battery constraints

Lithium ion batteries are the costliest batteries available with ninety percent efficiency in its charging and discharging issues. These batteries also found application in mobile phones, laptops and other portable electronic applications. With Cobalt oxide as cathode and graphite as anode, these batteries last for four plus years. Phosphate variant batteries will give service for 10 plus years, but too costly to invest on.

In general, Li-ion batteries can be characterized as energy storage systems that rely on insertion reactions from both electrodes where lithium ions act as the charge carrier [18]. Given this broad definition, there are several different cell chemistry's that make up the Li-ion battery family. Most Li-

ionbatteries use a negative electrode [19] principally made from carbon (e.g., graphite) or lithium titanate (Li₄Ti₅O₁₂), with some novel materials under development, namely, Li metal and Li(Si) alloys. The electrolyte used varies based on the choice of electrode materials, but is typically composed of a mixture of lithium salts (e.g., LiPF₆) and an organic solvent (e.g., diethyl carbonate) to allow for ion transfer. These components will be discussed in more detail below. A separating membrane is used to allow lithium ions to pass between the electrodes while preventing an internal short circuit [20]. This arrangement is shown conceptually in Figure 2, with the transport aspects of the battery when operating as an energy source (i.e., a galvanic device) illustrate the electrons travel from the negative electrode to the positive electrode while simultaneously the Li⁺ ions travel from the negative electrode through the electrolyte to the positive electrode to maintain electro neutrality. When the system is operated in charge mode (i.e., as an electrolytic device) the electron current and Li⁺ ion flow is reversed.

2.5. Voltage Source Inverter

Inverter in Power-Electronics refers to a class of power conversion circuits that operate from a dc voltage source or ac dc current source and convert it into a symmetric ac voltage or current. It does reverse of what ac-to-dc does. The input to the inverter is a direct dc source or dc source derived from an ac source. For example, the primary source of input power may be utility ac voltage supply that is converted to dc by an ac - dc rectifier with filter capacitor and then back to ac using an inverter. Here, the final ac output may be of a different frequency and magnitude than the input ac of the utility supply. If the input dc is a voltage source, the inverter is called a Voltage Source Inverter (VSI). The simplest dc voltage source for a VSI may be a battery bank or a solar photovoltaic cells stack. An ac voltage supply, after rectification into dc can also serve as a dc voltage source.

3. RESULTS AND DISCUSSION

Based on the design and simulation in MATLAB some of the results are discussed here, Figure 3 shows the solar panel peak power that is, by the simulation the peak voltage will get the peak power from the solar panel. In the figure 4 shows the solar production, In this figure 5 will explain the boost converter output that is a constant DC. The output is based on the voltage and current from the solar panel and pulse from the MPPT system, These figure 6 and 7 will shows the SOC and Nominal discharge characteristics of battery that is Li-Iron battery, The figure 8 will shows the resultant voltage and current characteristics that will be the output of boost converter and bidirectional boost converter. Figure 8 will shows the torque Vs speed characteristics, the final simulation result of solarpowered water pump.

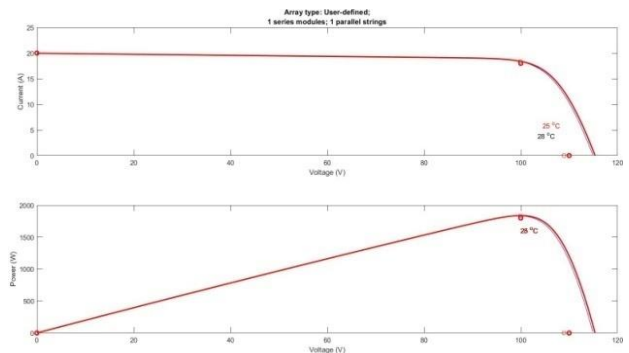

Fig.3. Solar panel output

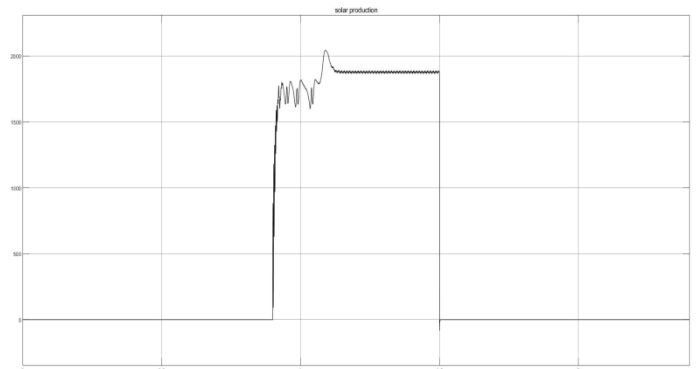

Fig.4. Solar Production

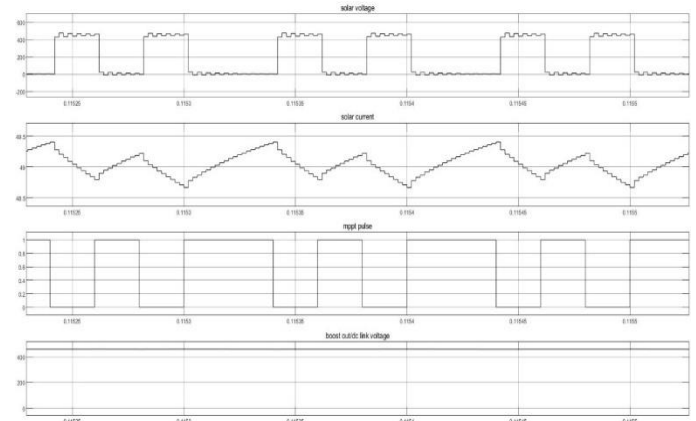

Fig.5. Boost converter output

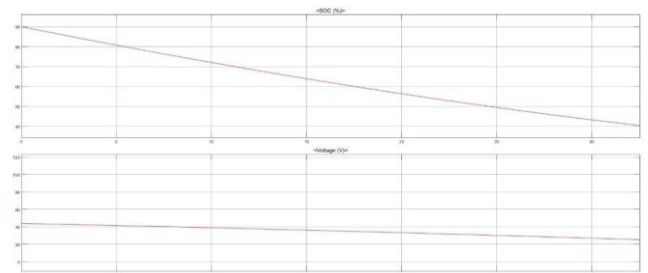

Fig. 6 . Soc of battery

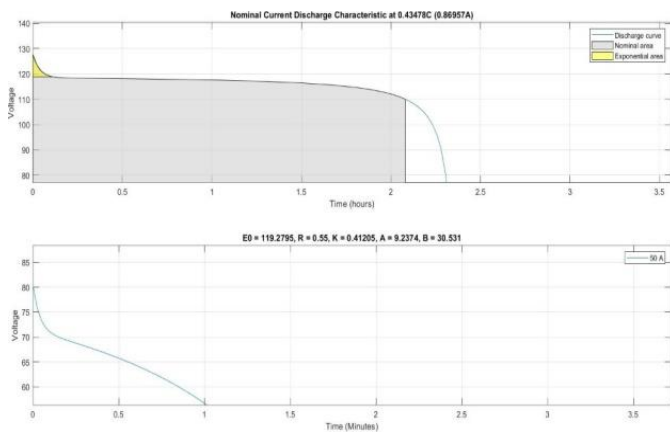

Fig.7. Nominal Discharge characteristics

The different resultant wave forms is shown here, from the we understood that our expected system achieved the desired performance level

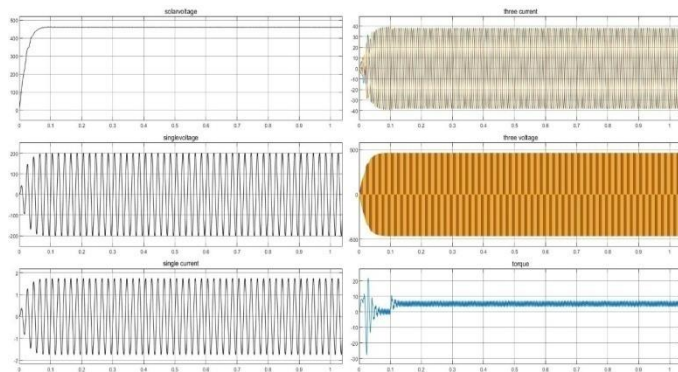

Fig.8.resultent wave forms

4. CONCLUSIONS

In this paper, introduces solar pump for agricultural purpose in remote areas. The power output of a Solar system is greater than that for a diesel, gasoline, or electric system, solar power is more cost competitive when the irrigation system with which it operates has a low total dynamic head. A solar PMSM driven water pumping system is designed and the performance is realized through simulation studies and experimental validation are done by MATLAB/SIMULINK. The use of PMSM has improved the efficiency of the system. Hence the presented system gives a fast, efficient and reliable solution for solar water pumping. The use Li-Iron batteries will leads to increases the life span of the system. By this no wastage of solar power, half time it will be used for pumping system for agriculture next half it used to charge the battery and uses the power for domestic purpose. In the future, when the prices of fossil fuels rise and the economic advantages of mass production reduce the peak watt cost of the photovoltaic cell, photovoltaic power will become more cost-competitive and more common.

REFERENCES

- [1] Shadab Murshid, Member IEEE Department of Electrical Engineering Indian Institute of Technology Delhi New Delhi, Bhim Singh, Fellow IEEE Department of Electrical Engineering Indian Institute of Technology Delhi "A Novel Control Scheme for Solar PV Fed PMSM Driven Energy Efficient Water Pumping System", 2018 IEEE.
- [2] Shadab Murshid, Member, IEEE and Bhim Singh, Fellow, IEEE "Single Stage Autonomous Solar Water Pumping System Using PMSM Drive" IEEE 2020.
- [3] Alivarani Mohapatra, Byamakesh Nayak, K.B. Mohanty, "Current Based Novel Adaptive PO MPPT Algorithm for Photovoltaic System Considering Sudden Change in the Irradiance", 2014 IEEE International Conference on Power Electronics, Drives and Energy Systems (PEDES). Mohammad Ahmad, Anil Kumar Jha, Sitaram Jana, Kishore Kumar, "Simulation and Performance Analysis of a Grid Connected Multilevel Inverter Considering Either Battery or Solar PV as DC Input Sources",
- [4] Shadab Murshid, Member, IEEE and Bhim Singh, Fellow, IEEE, "Single Stage Autonomous Solar Water Pumping System Using PMSM Drive", 0093-9994 (c) 2020
- [5] C. Wu, C. Chang, Y. Zhang, J. Hu and Y. Chen, "Design of a low EMI boost converter using bi-frequency PFM control mode," 2015 International Symposium on Next-Generation Electronics (ISNE), Taipei, 2015, pp. 1-4, doi: 10.1109/ISNE.2015.7131966
- [6] Mehdi Alimardani, Mehdi Narimani, Mehdi Narimani, "A New Approach to Improve Li-ion Battery Lifetime in Home Energy Storage System with Photovoltaic Modules", 2018 IEEE Canadian Conference on Electrical Computer Engineering (CCECE).
- [7] Z. Salam and C. J. Goodman, "Compensation of fluctuating DC link voltage for traction inverter drive," 1996 Sixth International Conference on Power Electronics and Variable Speed Drives (Conf. Publ. No. 429), Nottingham, UK, 1996, pp. 390-395, doi: 10.1049/cp:19960946.
- [8] Mohd. Kashif, Member IEEE and Shadab Murshid, Member IEEE and Bhim Singh, Fellow IEEE, "Super Twisting SMC Based Speed Sensor-less PMSM Driven Solar PV Water Pumping System", 978-1-5386-4996-1/18/\$©2018 IEEE. 3rd IEEE International Conference on "Computational Intelligence and Communication Technology" (IEEE-CICT 2017).
- [9] T. Feng, Q. Li, F. Wang, and W. Zhang, "Verification and implementation of the non-inverting buck-boost converter in energy harvesting battery charger," 2012 7th IEEE Conference on Industrial Electronics and Applications (ICIEA), pp. 855-859.

- [10] Shashi Shekhar Giri, M.Tech (Power System), Aziz Ahmad, Professor, Vimal Katiyar, Research Scholar, "Avoiding Power Clipping Losses by Inverter having High DC-to-AC Loading Ratio in Grid Connected Solar PV Plant Using Battery Energy Storage System", 2019 2nd International Conference on Power Energy, Environment and Intelligent Control (PEEIC) G. L. Bajaj Inst. of Technology and Management Greater Noida, U. P., India, Oct 18-19, 2019.
- [11] Amit Kumar Gupta, Vaibhav Pawar, Madhuwanti S. Joshi, Vivek Agarwal and Deepak Chandran, "A Solar PV Retrofit Solution for Residential Battery Inverters", 978-1-5090-5605-7/17/©2017 IEEE.
- [12] Abhishek Kumar, Seema, Bhim Singh, Rashmi Jain, "Double Stage Grid-Tied Solar PV System Using HC-LMS Control", 978-1-7281-6664-3/20/©2020 IEEE.
- [13] Yogesh Mahadik, Vinayak Ansurkar, Akshay Kadam, "Novel Multi- Source Inverter Based Hybridization Scheme for Electrical Energy Storage System Using Renewable Source", International Conference on Inventive Systems and Control (ICISC 2019) IEEE Xplore Part Number: CFP19J06- ART; ISBN: 978-1-5386-3950-4.
- [14] M. Haris, M. K. Pathak and P. Agarwal, "Comparison of SPWM multilevel inverter fed PMSM drive with two level inverter fed drive," International Conference on Recent Advances and Innovations in Engineering (ICRAIE on 2014), Jaipur, 2014, pp. 1 to 5, doi: 10.1109/ICRAIE.2014.6909123.
- [15] Jagruti N. Mahajan, Prof. Ashok M. Jain, "Conversion of Existing In-verter into Solar Inverter", Proceedings of the IEEE 2017 International Conference on Computing Methodologies and Communication (ICCMC).
- [16] Shadab Murshid, Member, IEEE and Bhim Singh, Fellow, IEEE, "Analysis and Control of Weak Grid Interfaced Autonomous Solar Water Pumping System for Industrial and Commercial Applications", 0093-9994 (c) 2019 IEEE.