

Design and Implementation of Low Cost IoT based Smart Refrigerator

Dr. K. Deepti¹, Pranavi Myneni*, Sri Sai Bhavishyya Muppalaneni², Banapuram Goutham³

¹Asst Professor Dept of ECE, Vasavi College of Engineering, Hyderabad, India

*Department of ECE, Vasavi College of Engineering, Hyderabad, India

²Department of ECE, Vasavi College of Engineering, Hyderabad, India

³Department of ECE, Vasavi College of Engineering, Hyderabad, India

Abstract - With the ceaseless enhancement of technologies in various sectors human lives have been directed towards a smarter regime. The devices are being programmed to being smart in order to cater our needs. Refrigerator is a device that is used worldwide for storage of food. With the bustling lifestyle, people often tend to resort to fast foods over home cooked meals. The proposed design of smart refrigerator deals with maintaining and notify the users if they run out of groceries. It is also designed to sense the quality of the foods which prevents further food spoilage. The monitoring and notifications regarding the food status as well as the quality of the food would be done using an Android App.

Key Words: – ESP8266, Load Cell, HX711, DHT11, MQ5 gas sensor, IR sensors, Internet of Things, Android App

1. INTRODUCTION

In this modern era, humans are able to interact with things around them with the help of Internet of Things(IoT). IoT can be defined as interrelation and interconnection of objects or things through which data is collected and transfer or stored over a wireless network. We have come across smart home automation projects in the recent years. Domiciliary is one of those prominent zones of smart devices, one of which is the refrigerator. Refrigerator is the main appliance that is used to store vegetables, fruits, milk, etc. Due to the busy work life schedule humans tend to neglect their health and do not pay much heed to the contents, inside the refrigerator. This not only hinders their healthy lifestyle but also leads to increase in food wastage. Any change in the environmental settings inside the refrigerator can also lead to problems. In this paper, we propose a smart refrigerator that helps to monitor the food status as well as the quality of food which would help the users to lead a healthier lifestyle. The main objectives of the proposed design are-Monitoring the amount of vegetables and fruits present inside the refrigerator, monitoring the temperature and humidity levels, monitoring the quality of food and notifying the user in case of less amount of groceries present if there is any unusual change in the temperature levels and if spoilage of food is detected.

2. LITERATURE REVIEW

A low cost cold storage management system is proposed by the author based on IoT. The approach uses IoT devices, cloud services and android application. UV sensor is used to detect the presence of food from which the quantity is calculated. A MQ4 gas sensor is used to detect the methane gas which determines the freshness of the food[1]. The system is implemented across a client and server environment. The system checks the packaging of the food items through scanning. The packaging includes a printed QR code or other type of barcodes which is scanned to receive information encoded by the code. Sometimes an RFID tag is used is scanned and the information stored in the tag is received [2]. The system is used to identify various gases present in the atmosphere and calculate their concentration in ppm. It receives data from gas sensors MQ-2, MQ-4 and MQ-135. If the gas concentration reaches above the threshold value an alarm goes off and in addition a notification via SMS is sent with the help of a GSM module[3]. The proposed system sense the weight of the food items placed in the refrigerator and sends a notification through a mobile app if the value goes below the threshold level[4]. The author proposed a system which manages the contents present inside the refrigerator and provides the users with different cooking techniques depending on the items that are available[5].

3. PROPOSED SYSTEM

The proposed system uses ESP8266 as the microcontroller. It uses DHT11 sensor to sense the temperature and humidity. IR sensors are used to maintain the count of items like milk bottles, tetra packs, eggs etc. Load cell along with HX711 which load cell amplifier is used for measuring the weight of the vegetable and fruits tray mainly along with other items. The MQ-5 gas sensor measures the methane concentration in ppm which is used to indicate the freshness of the food items. Magnetic Door sensor is used to sense the door movement. All the data retrieved by the sensors is uploaded and stored in the ThingSpeak cloud platform. An android application is built using MIT App Inventor 2 where all the data is displayed by retrieving the data from the cloud. A corresponding notification is sent to the user if the data from any of sensors crosses the threshold values.

4. SYSTEM ARCHITECTURE

The model proposed uses microcontroller ESP8266 which has an in built Wifi module that is used to communicate and connect with the ThingSpeak cloud platform. It has GPIO pins which are used to connect to the sensors.

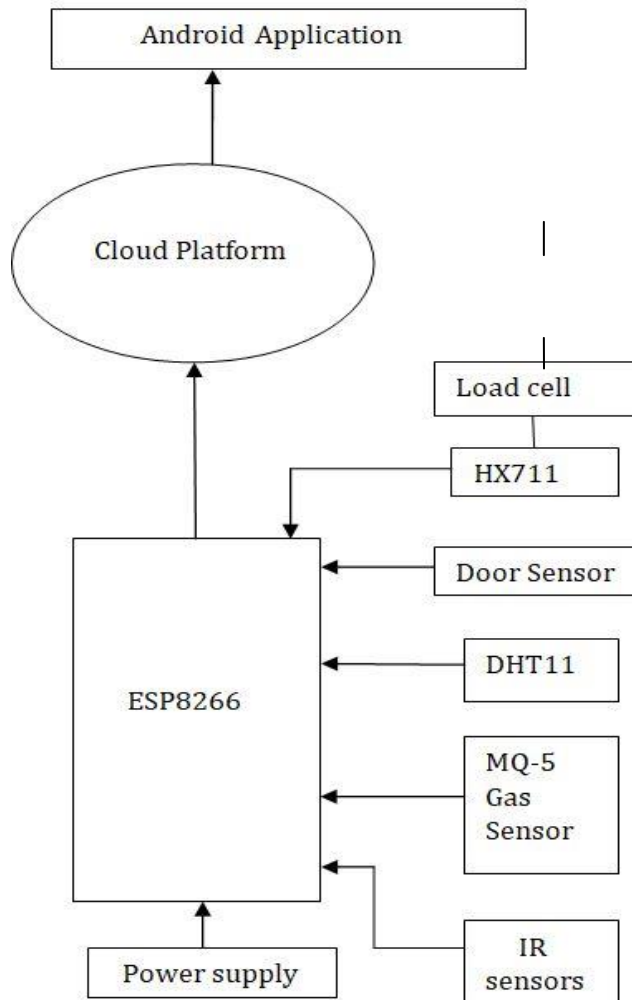

Fig-1: Block Diagram

From Fig 1, the different sensors used in the model and how they are connected to the ESP8266 microcontroller is observed. The data received from the sensors is uploaded to the cloud platform and then later accessed by the Android App.

5. IMPLEMENTATION DETAILS

Arduino IDE is a cross platform application that is used to write and upload programs to arduino compatible boards. It uses C and C++ functions. It also provides a software library from wiring project which provides us with many input and output procedures. Fig.2 indicates an example code for blinking of an LED using Arduino IDE.

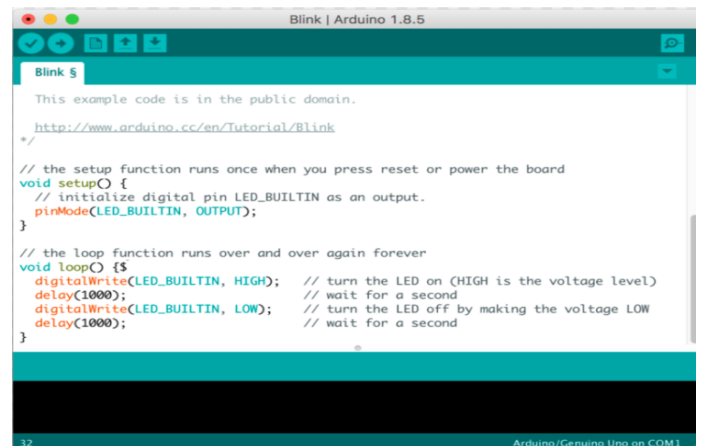

Fig-2: Arduino IDE platform

The ThingSpeakcloud platform is used to store the data received from the sensors. In the platform we create a channel and are provided with a unique channel number , write and read API keys. These keys are used to write and read the data from the sensor to the cloud and from cloud to the program of other applications respectively. We can view the data in the form of a graph or numerical values.

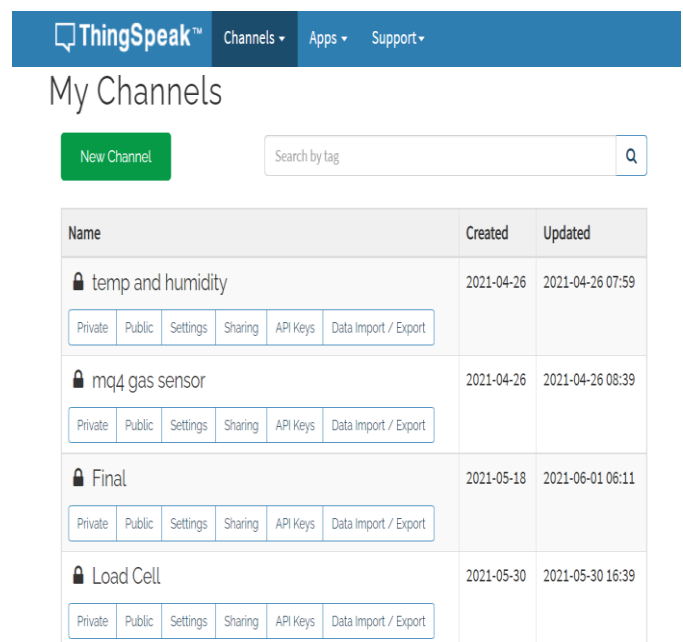

Fig- 3: Channels in ThingSpeak cloud

From Fig 3, it is observed that there are different channels that have been created. Each channel can accommodate upto eight fields. Each channel has a unique channel number and write and read API keys.

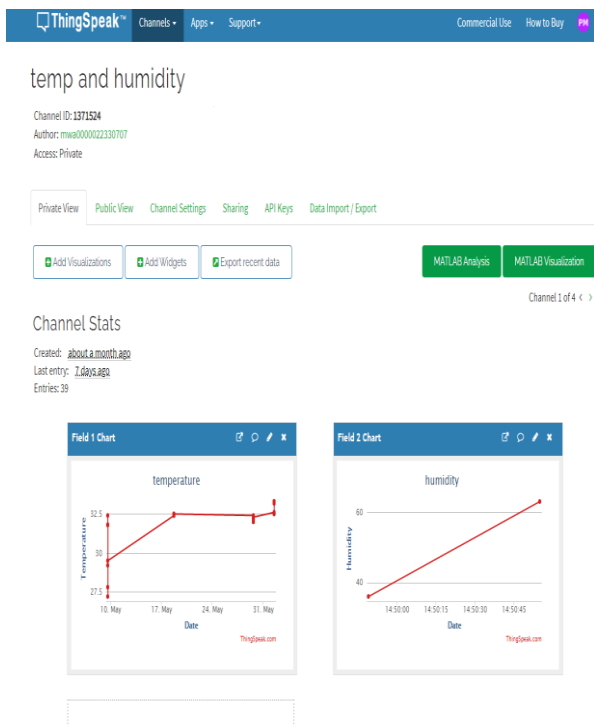

Fig -4: Data graphs present inside a channel

Fig 4 shows the two fields- temperature and humidity created inside a channel to display the data received from the sensor in the form of a graph. The channel ID is displayed at the top.

The Android App is created with the help of MIT App Inventor 2. This is a web application integrated tool provided by google and is maintained by Massachusetts Institute of Technology. It is an open source software. It has block based tools which help us build complex apps easily.

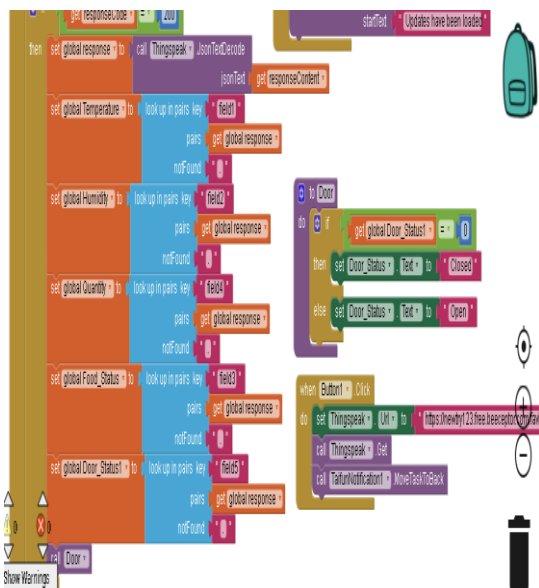

Fig- 5: MIT App inventor 2 block code

6. RESULTS

The data from the DHT11 sensor, MQ-5 gas sensor, IR sensors and load cell is uploaded into a single channel in the ThingSpeak cloud using write API key.

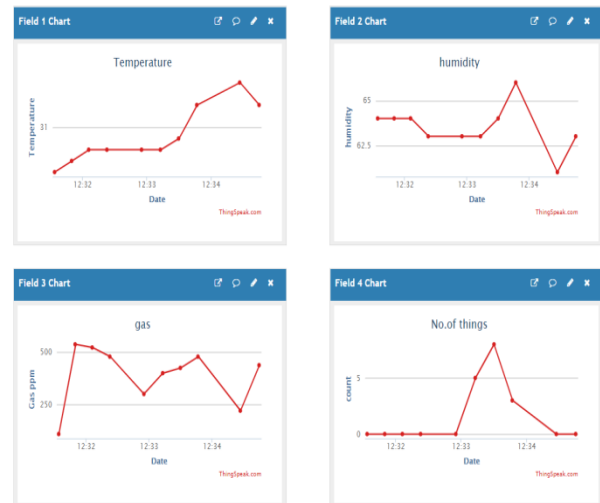

Fig -6: Data from different sensors such in the form of graphs

Fig 6. shows the data received the sensors which are displayed in the form of graphs. Each component is given a field and the data is uploaded under that field respectively.

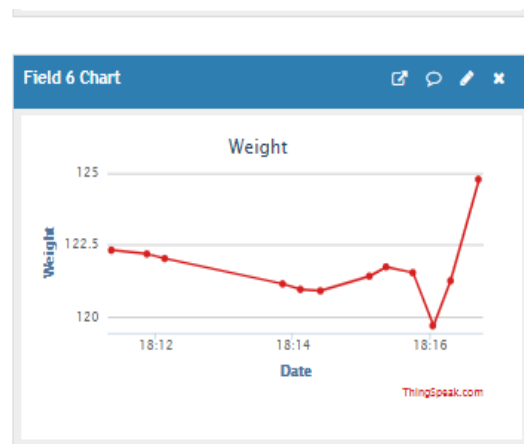

Fig -7. Weight of the food items measured using load cell.

Fig 7 indicates the weight of different food items measured using the load cell. From the graph it is observed that weight of the food items is represented on the y-axis while the x-axis displays the time at which the food item was measured and the value has been uploaded into the cloud.

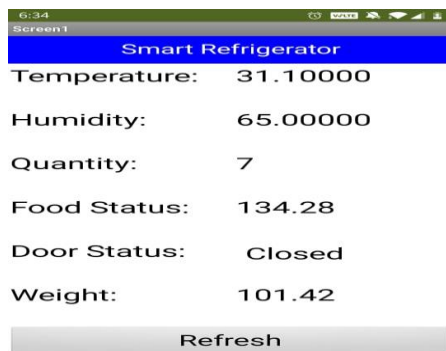

Fig-8: Data values displayed on the app

Fig-8 displays the screen of the app that is available to the user. Different attributes are displayed such as quantity which refers to the amount of tetra packs or bottles, food status referring to the freshness of the food and so on.

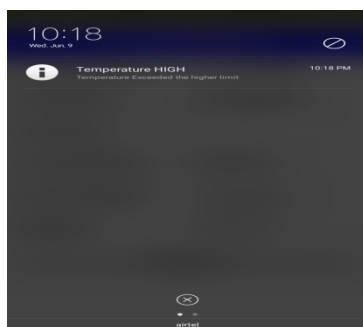

Fig-9: Temperature Alert Notification display

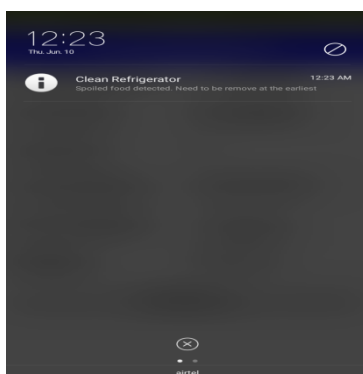

Fig-10: Presence of spoiled food Alert Display.

Fig 9 and Fig 10 show that a notification regarding the temperature of the refrigerator and presence of spoiled food respectively has been sent to the user when the value from a sensor has crossed a threshold level thereby alerting the user.

7. CONCLUSION

The smart refrigerator model monitors the temperature levels, weight of the food items as well as the freshness of the foods. It notifies the user if any abnormality is sensed in the temperature and gas sensor readings. It also alerts the user in case he is running out of the groceries. Overall it helps the user to achieve a healthy lifestyle. Smart refrigerator is user friendly and economical.

REFERENCES

- [1] BikrantSarmah, G.Aruna “Detection Of Food Quality and Quantity at Cold Storage using IoT” IEEE September 2020.
- [2] Emily Moin, “Smart Refrigerator for grocery management” Technical disclosure commons May 6, 2015.
- [3] P. Nagendra Siva Kumar ,Dr. A. Kamala Kumari “Design of Gas Detection and Monitoring System using IoT” ,International Journal of Engineering Research and Technology(IJERT), Volume 8 ,Issue 11,November 2019.
- [4] Deepti Singh, Preet Jain, “IoT Based Smart Refrigerator System”, International Journal of Advanced Research in Electronics and Communication Engineering (IJARECE), Volume 5, Issue 7, July 2016.
- [5] Suhuai Luo; Hongfeng Xia; Yuan Gao; Jesse S. Jin; RukshanAthauda, " Smart Fridges with Multimedia Capability for Better Nutrition and Health", 2008 International Symposium on Ubiquitous Multimedia Computing.