

MILITARY DRONE

Shikhar Srivastava¹, Achintya Kumar Gupta², Vivek Singh³, Saurav Tripathi⁴, Santosh Dubey⁵

¹Shikhar Srivastava, Dept. of Electronics & Com. Engineering, UCER, Naini, Prayagraj

²Achintya kumar Gupta, Dept. of Electronics & Com. Engineering, UCER, Naini, Prayagraj

³Vivek Singh, Dept. of Electronics & Com. Engineering, UCER, Naini, Prayagraj

⁴Saurav Tripathi, Dept. of Electronics & Com. Engineering, UCER, Naini, Prayagraj

⁵Asst Professor Santosh Dubey, Dept. of Electronics and Communication Engineering, United College of Engineering and Research, Naini, Prayagraj, Uttar Pradesh, India

Abstract - An unmanned aerial vehicle (UAV) (or uncrewed aerial vehicle, commonly known as a drone) is an aircraft without a human pilot on board and a type of unmanned vehicle. UAVs are a component of which include a UAV, a ground-based controller, and a system of communications between the two. The flight of UAVs may operate with various degrees of autonomy: either under remote control by a human operator or autonomously by onboard computers.

This project will consist of a drone which will be equipped with guns and some other security tools to make it suitable for military purpose of this project will be very helpful in dealing with the terrorist hidden inside the buildings and in the mountain caves as well as in the woods.

1. INTRODUCTION

This project mainly focuses on the security of the military persons who keeps on dealing with terrorist activities even this project will be helpful in reducing the casualties during combat with the terrorist or robbers.

This project consists of a drone equipped with a gun and camera which will be helpful in dealing during small wars, but the main aim behind designing this project is its usefulness in dealing with the arsonist hidden in the buildings or who have captured the building. The drone would be manually controlled by the user. This drone will also consist of a GPS system which will be helpful in getting the live locations of the extremist.

PRINCIPAL

Drones work on the principle of relative nature of forces or in short Newton's Third law of motion where propeller exerts force on air and in reaction air lifts the drone.

Military drone is based on the working principle of Arduino UNO R3 and Flight Controller.

MAJOR COMPONENTS

1. **Brushless Motor:** It consists of a rotor with a permanent magnet and a number of electromagnets surrounding it, these are also called poles. Brushless motors can have anywhere from 2 to 14 poles. The greater the number of poles the more precisely the motor can be controlled. By changing the connections on these wires you can have the motor spin clockwise or counter clockwise.

2. **Electronics Speed Controller:** ESC will have three sets of wires. There are three heavy-gauge wires that connect to the three wires on your brushless motor.

Two other heavy-gauge wires connect to power distribution board, this supplies voltage to the ESC and motors. There will also be three smaller wires that connect to your flight controller.

3. **Flight Controller:** The Flight Controller is the brain of the quadcopter. This is the device that controls the speed of your motors by sending signals to your ESCs. The flight controller has more features and is coupled with sensors such as gyros, accelerometers, sonar, GPS and magnetometers.

4. **Arduino Uno:** It is a microcontroller board based on the ATmega328P. It has 14 digital input/output pins (of which 6 can be used as PWM outputs), 6 analog inputs, a 16 MHz ceramic resonator, a USB connection, a power jack, an ICSP header and a reset button. It can be powered by the USB cable or by an external 9-volt battery, though it accepts voltages between 7 and 20 volts.

5. **Battery:** Capacity of the battery goes up so does its weight, and adding weight to your quadcopter will reduce the flight time as more current will be required from your motors to lift the payload. The principal battery specification is its current capacity, which is rated in milliamps per hour or "mAh". Another specification of the battery is its voltage. Batteries consist of a number of cells, each cell of a common LiPo battery is capable of delivering 3.7 volts.

METHODOLOGY

Military drone is based on the working principle of Arduino UNO R3. This drone has various modules which are

programmed to perform particular task. Our military drone is divided into two sections as shown in figure given below section 1 as well as section 2 .

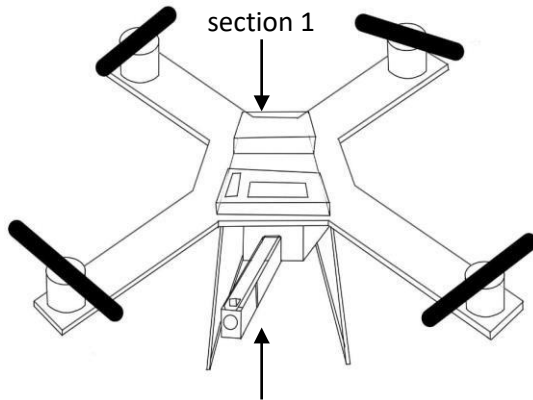

Fig -1: Model of the Military Drone.

Section 1:- This section consist of components required for the flight system of the drone and component used here are flight controller(KK2 1.5), motors, propellers, electronic speed controller(ESC), battery, radio transmitter and receiver.

Section 2:-This section consist of components required for the firing of firearm and consist an Arduino UNO, Bluetooth module, servo motor and firearm.

Unmanned aerial vehicle technology covers everything from aerodynamics of the drone, materials in the manufacture.

An unmanned aerial vehicle system has two parts, as described above. The engineering material used to build the drone are designed to absorb vibrations.

The working of firing of firearm is given in the block diagram below.

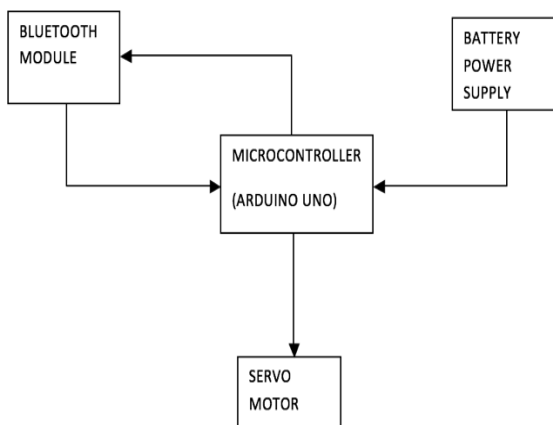

Fig -2: Block diagram of firearm.

Working starts with transfer of message of from remote control to flight controller via Bluetooth module and motors starts moving rapidly and finally drone gets lifted and there is control of gun too which helps gun to move in the form of Servo Motor.

The working of drone is explained in the block diagram given below

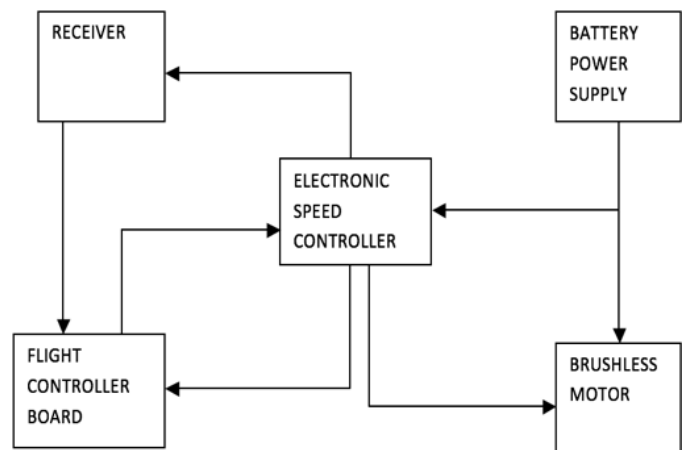

Fig -3: Block diagram of Military Drone.

The data is received from the receiver boarded on the drone and it is send to the flight controller. The flight controller makes necessary adjustments and it controls the electronic speed controller which regulates the voltage of the brushless motor. The whole system is powered by the lithium polymer battery.

ALGORITHM

The basic algorithm to operate the trigger mechanism of the firearm is given below :

- STEP 1. Set SERVO ANGLE = 0
- STEP 2. Read INPUT
- STEP 3. if INPUT == 0
- STEP 4. GOTO STEP 2
- STEP 5. if INPUT == 1
- STEP 6. Increase SERVO ANGLE
- STEP 7. if SERVO ANGLE < 90
- STEP 8. GOTO STEP 6
- STEP 9. if SERVO ANGLE > 90
- STEP 10. Decrease SERVO ANGLE
- STEP 11. if SERVO ANGLE > 0
- STEP 12. GOTO STEP 10
- STEP 13. if SERVO ANGLE = 0
- STEP 14. STOP

FLOWCHART

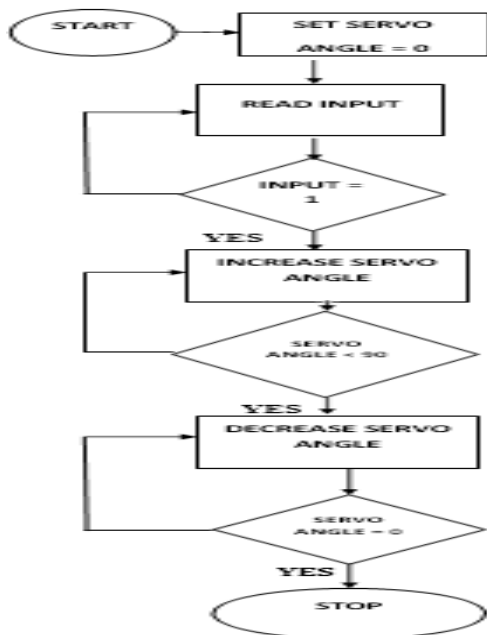

CONCLUSIONS

Military Drones will play a crucial role in future warfare and they will decide where the nation will stand in battleground. As a result, we have made a drone which is equipped with gun and a technologies including both flight controller and Arduino, where Arduino will control gun part and Flight controller will help to balance the whole system of drone, it will also balance the recoil of drone too. While other parts such as ESC's and Motors with remote controller are the base of drone which makes it completed.

Military Drone is overall package in the Defense system which will be in attack mode as well as in serving mode such as spying and transportation of medical supply.

FUTURE ENHANCEMENT

1. Future Warfare are depends on Drones and Fighter jets.
2. Military Drones will help it's native nations to be in front in every critical condition either it is warfare or opponent strike.
3. Military Drone will play a major role in Natural Disaster from gathering information to helping V hostages.
4. Over time as militaries have incorporated greater communication, training, and organization, they were able to fight in an increasingly sophisticated manner, leveraging more advanced doctrinal forms, with each evolution superior to the previous.
5. Drones can go places that humans can't access, so they are an ideal solution for dangerous search and rescue

efforts, as well as for delivering emergency supplies to remote locations and disaster areas.

6. Military Drones are equipped with Gun. As a result, some drones could assume responsibility for missions such as defensive counterair or suppression

REFERENCES

- 1) <https://www.arduino.cc/>
- 2) <https://atomdrones.com/how-do-drones-work-and-what-is-drone-technology/#:~:text=Working%20Principle%20of%20Drones%20%2DMulti,can%20go%20up%20and%20down.&text=Drone%20can%20fly%20in%20all,%2C%20down%2C%20left%20and%20right.>
- 3) <https://www.dronetrest.com/t/kk2-1-flight-controller-guide/379>
- 4) <https://www.elprocus.com/electronic-speed-control-esc-working-applications/>
- 5) <https://www.arduino.cc/en/Tutorial/LibraryExamples/Sweep>
- 6) <https://www.arduino.cc/en/Tutorial/LibraryExamples/Sweep>
- 7) <https://softwarehut.com/blog/tech/arduino-bluetooth-controller-tutorial>
- 8) <https://www.instructables.com/HW30A-Motor-Speed-Controller/>

AUTHORS



“Shikhar Srivastava, Dept. of Electronics and Communication Engineering, UCER, Naini, Prayagraj”



“Achintya Kumar Gupta, Dept. of Electronics and Communication Engineering, UCER, Naini, Prayagraj “



“Vivek Singh, Dept. of Electronics and Communication Engineering, UCER, Naini, Prayagraj “



“Saurav Tripathi, Dept. of Electronics and Communication Engineering, UCER, Naini, Prayagraj “