

Wired Smart Agricultural Sensor Network

Apoorv Madhogarhia

Student, Dept. of Electronics and Communication Engineering, Sardar Vallabhbhai National Institute of Technology, Surat, Gujarat, India

Abstract - With the rapid growth in world population, food consumption worldwide also grows rapidly. A rapid escalation in food production to cater to the growing demand is not an easy task. Agriculture being the oldest industry has evolved so far to the age of what can now be termed as The Third Green Revolution. The world is witnessing yet another fundamental modification with the wake of a new industrial revolution that employs application of modern Information and Communication Technologies into agriculture, in order to deliver a sustainable agricultural production. Problem in today's farming is that: Uncertain, unreliable & erratic rainfall leads to water wastage due to lack of modern equipment; absence of proper crop monitoring and waste management processes hinder the crop yield. As a solution, we propose a system wherein the model reads the temperature and warns the farmer whenever it becomes unsuitable for crop production, reads moisture and automatically starts the pump for irrigation when moisture level drops to a certain value, alarms the farmer when waste is converted to manure, automatically switches lights ON/OFF depending upon the exposure of crops to sunlight and password protected door. For this model, we have used Arduino UNO, temperature sensor, soil moisture sensor, methane gas sensor, photoresistor, keypad, servo door, DC Motor. This model would lead to higher crop yield, increase productivity, improved safety, and shorter work weeks of labour.

Key Words: ARDUINO, IOT, SMART AGRICULTURE, SENSOR, METHANE, MOISTURE

1. INTRODUCTION

Although smart agriculture has been adopted in a few countries; the agriculture industry in India still needs to be modernized with the involvement of technologies for better production, distribution and cost control discusses the modules of monitoring of soil and weather conditions as well as remote irrigation control in terms of technologies used was the leading inspiration for this project topic

1.1 AGRICULTURE IN INDIA

Agriculture, forestry, and fishery had a Gross Value Added (GVA) of Rs.19.48 lakh crore (US\$ 276.37 billion) in FY20 (PE). Food grain production is expected to hit a new high of 295.67 million tons in the 2019-20 crop year (MT). The

Indian government plans to produce 298 MT of food grain in 2020-21[1]

1.2. AGRICULTURAL TARGETS

Under the PM Matsya Sampada Yojana, the central government plans to invest \$9 billion in the fisheries sector over the next five years. By 2024-25, the government wants to increase fish production to 220 lakh tons.[2]

1.3. AGRICULTURAL TARGETS

Smart Agriculture employs technical resources to assist farmers in different stages of the production process, including plantation monitoring, soil management, irrigation, pest control, delivery tracking, and so on [3]. Temperature, luminosity, humidity, pressure, video cameras, agricultural information management systems, global positioning systems (GPS), and communication networks are only a few examples of such resources [4]. The integration of technological resources into the agricultural production process is a relevant issue. From an economic point of view, the smart agriculture market is expected to have a revenue of US \$10 billion.

2. HARDWARE

The hardware consists of Arduino Uno R3 microcontroller, photoresistor, keypad, LEDs, LCD Display, TMP36, DC Motor, Power Supply, Methane Gas Sensor, Buzzer, potentiometer, Keypad and servo motor.

3. WORKING

3.1 ARDUINO 1

Servo motor acts as a door to the agriculture farm. The user is asked to enter the password in the keypad if he wants to open the door. If the password is incorrect the buzzer will buzz. If the password is correct the servo door will open.

Manure pit - Organic wastes also generate large amounts of methane as they decompose. Methane sensor will detect whether the waste is converted to manure based on methane conversion and buzzer will blow on conversion.

When the photoresistor is exposed to light, the photoresistor has very little resistance, so current can flow through the circuit. That current is read by the analog pin of Arduino. As this current is sufficient, Arduino gives active low to relay, hence turning OFF the circuit. The bulb will be switched off due to discontinuity in circuit.

When exposed to darkness, the photoresistor has very high resistance, so current cannot flow through the circuit. That current is read by the analog pin of Arduino. As this current is not sufficient, Arduino gives active high to relay, hence turning ON the circuit. The bulb will be switched on due to continuity in circuit.

3.2 ARDUINO 2

TMP36 uses the property of diodes; as a diode changes temperature the voltage changes with it at a known rate. The sensor measures the small change and outputs an analog voltage between 0 and 1.75VDC based on it. To get the temperature we just need to measure the output voltage and calculate using formula.

Upon conversion into degree Celsius, if the temperature is above 35 degree Celsius the Arduino microcontroller will send an active high to the buzzer post which the buzzer shall buzz.

Soil moisture sensor has a potentiometer in it. The output of the soil moisture sensor changes in the range of ADC value from 0 to 1023. This can be represented as moisture value in terms of percentage using the formula given below. For zero moisture, we get a maximum value of 10-bit ADC, i.e., 1023. This, in turn, gives 0% moisture.

Due to the unavailability of soil moisture sensor in tinker cad, we have assumed potentiometer to be sensor. (As its output behaves exactly as a soil moisture sensor). It gives ADC values from 0 to 1023. In this project, we assumed these values as coming from soil moisture sensor.

This value is read by the analog pin of Arduino. Then we calculate the percentage of moisture using mapping. When moisture level is less than 30%, Arduino gives active high to red LED and dc motor (water pump). When moisture level is greater than 30% and less than 60%, Arduino gives active high to green LED and active low to dc motor (water pump). When moisture level is greater than 60%, Arduino gives active high to blue LED and active low to dc motor (water pump).

4. RESULTS

The projected was successfully simulated.

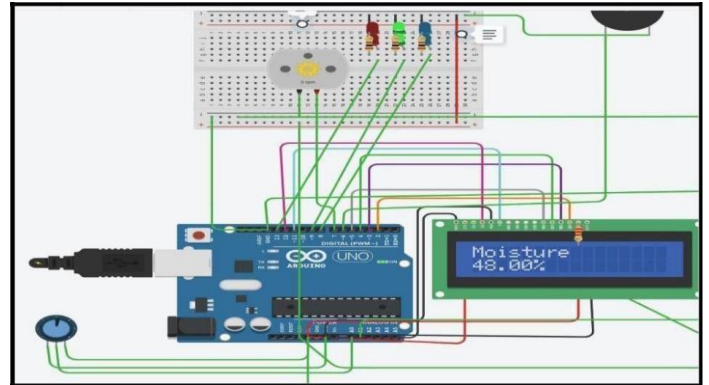

Fig -1: When moisture level is between 30% and 60% (Green led is on)

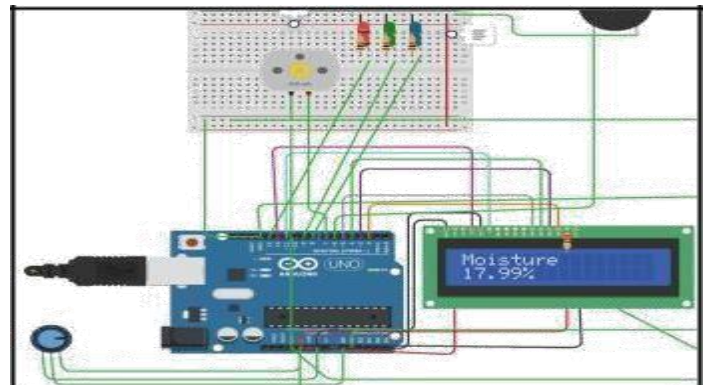

Fig -2: When moisture level is less than 30% (Red led is on and dc pump is on).

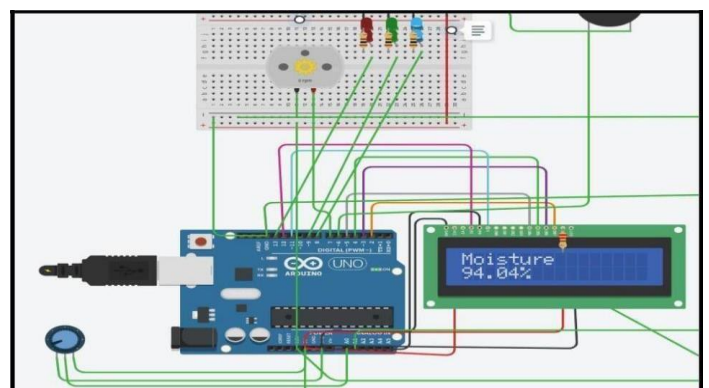

Fig -3: When moisture level is greater than 60% (Blue light is on)

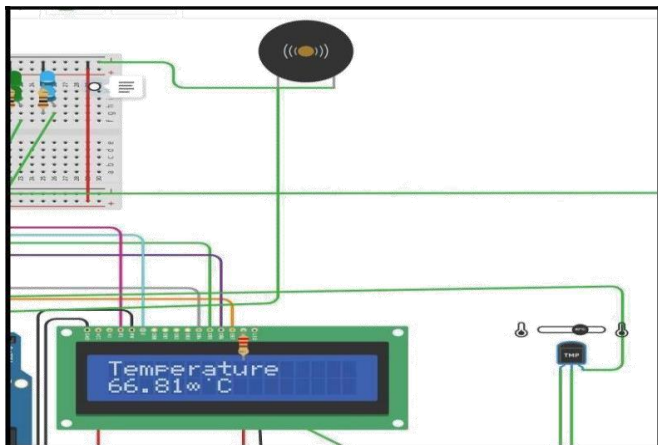

Fig -4: When temperature is greater than 35 degree Celsius. (Buzzer is ON)

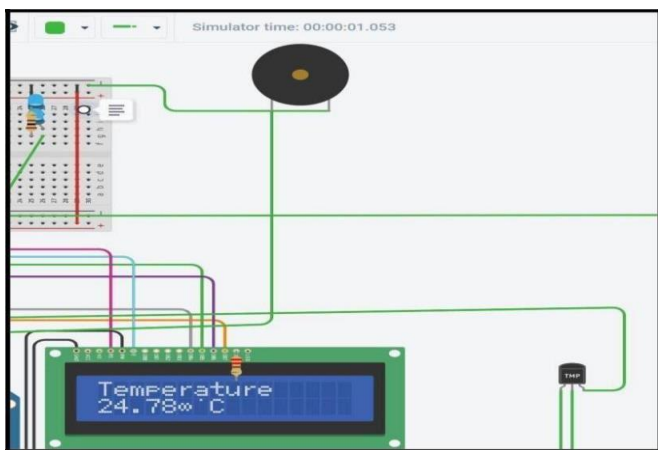

Fig -5: When temperature is less than 35 degree Celsius. (Buzzer is OFF)

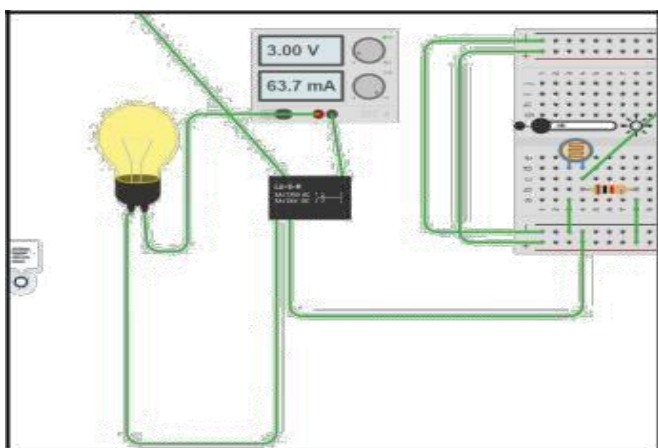

Fig -6: During night time.

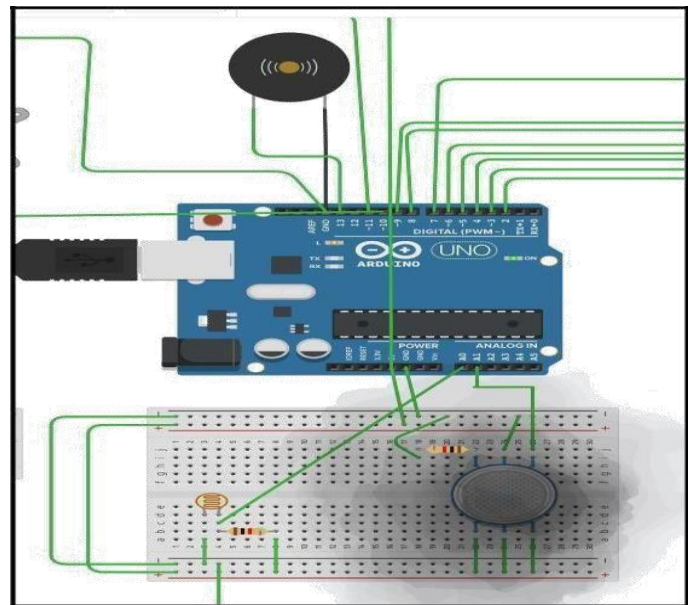

Fig. 4(l) When Methane Concentration is High (Buzzer is ON)

5. CONCLUSIONS

The proposed model explores the use of sensors in the agriculture sector. This model aims at increasing the crop yield by monitoring agriculture parameters such as temperature, moisture and lighting and taking actions without any human interference.

We have successfully simulated the password protected automated servo motor-based door system to enhance the security. Rest of the farm can be fenced. The password is entered in a keypad. The buzzer alarms everyone around if a wrong password is entered. Thus, ensuring security and avoiding chances of break in.

We have also simulated the methane gas sensor in an online Integrated Development Environment (IDE). The sensor turns on the buzzer and indicates that the waste dumped in the manure pit has been successfully converted into manure by the emission of methane gas. This increases the efficiency of the waste management system in terms of quality and time.

We have simulated an automated lighting system which turns the LED light bulb ON in low light conditions. A significant attribute of LED technology is the opportunity to reduce energy costs associated with electric lighting. Studies have shown that by increasing canopy photon capture efficiency and/or precisely controlling light output in response to the environment or to certain physiological parameters, energy efficiency and plant productivity can be optimized with LEDs.

We have also simulated a system wherein we read the temperature via TMP36. Using the formula given in the data sheet, we convert the reading into degree Celsius. For

now, we have used a buzzer that indicates high temperature to the farmer giving him a choice to lower the temperature by either watering or by using electric mode of atmosphere control of his choice according to his economic feasibility. The buzzer can also be replaced and customized

We have also simulated moisture indicating and controlling the system. Since the moisture sensor library was not available in the online simulator, we replaced the moisture sensor with the potentiometer. Assuming the potentiometer reading to be moisture sensor reading, we converted the reading in percentage terms. We indicated a blue light via LED when the moisture was above 60 %, we indicated a green light when the temperature was below 60% and greater than 30% and when the temperature was below 30%, we indicated a red light via LED and turned the DC motor on. This DC motor would pump the water and automatically irrigate the crops.

6. FUTURE SCOPE

The future scope of this project could include a variety of soil sensors like pH sensor, Rain sensor and then collecting and storing the data on firebase. This would make the predicting and analysing processes more accurate. It also includes making different data mining algorithms suitable for data analysis in agriculture.

This project can be converted into a wireless model wherein the larger part of the farm is covered by multiple sensors. The data can be collected in various forms as well. We can either have various microcontrollers or have a master-slave type model using relay nodes depending upon the usage. IoT can be further integrated to add the option of manual control over parameters using mobile applications.

We can also extend the features already provided. We can extend the feature of the light system in aeroponic farming (controlled indoor farming). Artificial lighting is a better option to present enough intensity to produce a healthy plant [97, 98]. In the conventional aeroponic system, the control of the light quantity present in the growth chamber is mostly done by farmers through observing the plant condition. However, it is a time-consuming and challenging task for the farmer to provide the required light concentration accurately. It could be a better option to use intelligent agriculture techniques to monitor the light intensity in the aeroponic system.

We can further add a voltage regulator with DC Fan to control the speed of the fan using an android app according to temperature values.

Thus, by integrating IoT, data science and further hardware this project has a potential of changing the face of agriculture in India in the long term.

REFERENCES

- [1] Jahromi, H. N., Hamedani, M. J., Dolatabadi, S. F., & Abbasi, P. 2014. Smart Energy and Water Meter: A Novel Vision to Groundwater Monitoring and Management. *Procedia Engineering*. 70: 877-881.
- [2] Husin, S. H., Hassan, M. Y. N., Hashim, N. M. Z., Yusop, Y., & Salleh, A. 2013. Remote Temperature Monitoring and Controlling. *International Journal for Advance Research in Engineering and Technology (IJARET)*. 1(9)
- [3] Monica Rozenfeld, Indoor farms could revolutionize agriculture, The institute – IEEE tech news resource online magazine, 23May2016 [5] Students boost food production with simple technologies, The institute - IEEE tech news resource online magazine, 23May2016.
- [4] Hashim, N., Mazlan, S., Aziz, M.A., Salleh, A., Jaafar, A., Mohamad, N., 2015. Agriculture monitoring system: a study. *J. Technology* 77,53–59 <https://doi.org/10.11113/jt.v77.4099>.