

# Design and Fabrication of Mini 5 Axis CNC Machine for Gemstone Carving

Quoc-Phong Pham<sup>1</sup>, Thach My Thuat<sup>2</sup>

<sup>1,2</sup>School of Engineering and Technology, Tra Vinh University, Vietnam.

\*\*\*

**Abstract** – The application of CNC technology in machining is becoming more and more popular in manufacturing, including fine art production. To contribute to the CNC industry, the paper describes the design and fabrication process of a 5-axis CNC machine used for gemstone carving. This research aims to propose a CNC machine model for jewellery making with a compact mechanical structure but can meet the machining criteria. Research results show that the movements of the machine meet the requirements in carving basic shapes in quartz and marble. This CNC machine can support the sculptors that are for making basic products for application in mass processing.

**Key Words:** CNC Machine, CAD/CAM/CNC, Fusion 360, Design, Mach3

## 1. INTRODUCTION

Nowaday, more and more CNC machines are used. The trend of making machines is taking place in the direction of automation in processing and production. In particular, the field of mechanical processing with a series of Computer Numerical Control (CNC) processing machines was developed such as 3-axis, 4-axis, 5-axis CNC machines, machining centers, high-speed CNC machines, etc. Therefore, mass production as well as product quality, are increasingly improved. CNC machines also show many advantages such as flexibility, automatic ability, high accuracy, processing complex shapes quickly with just one file of G-Code input to the machine. However, commercial CNC machines are used for industry with large capacity and very expensive. Besides, the infrastructure to install industrial CNC machines is also very costly. Accessible conditions of the people are very difficult for small-scale production investment. Recently, microcontroller technology has developed rapidly. Microcontrollers have been designed more professionally, and the cost has decreased significantly. Therefore, the demands of the design and manufacture of specialized CNC machines is necessary. The machine with compact size and low cost but still ensure efficient operation, contribute to gradually mastering CNC machine manufacturing technology gradually. That can help to replace high-cost imported equipment for handicraft, jewellery and sculpture products.

Many researchers have been carried out on CNC machines, including designing specialized CNC machine models for specialized functions [1-4]. In addition, there are many studies on manufacturing CNC machines that apply to specific machining purposes [5-8]. The above studies show that the trend of applying CNC technology is increasingly popular in many fields. The main objective of this research is

to create a 5 axis mini CNC machine that is to carve brittle material as gemstone. Kinematic of machine based on the real movements of craftsmen carving actual products at the workplace. In this study, Mach3 controller was used for operation and Fusion 360 was applied for CAD/CAM/CNC programming. The machine has been tested on some kinds of gemstone such as quartz and marble. Experiment results shown that products were made by the CNC machine can be accepted for commercial trading. The research results can be applied to handicraft production facilities, processing small-sized parts, stone or other highly hard and brittle materials.

## 2. MACHINE DESIGN

### 2.1 Kinematic analysis

Diamond tools popularly used for engraving gemstone are high precision tools, cutting surface are coated by diamond particles [9, 10]. Figure 1 presented the machine table with spindle used for gemstone carving and the movement directions of the diamond tool during machining. Although diamond particles are applied all over the tool surface, this type of tool construction is designed for edge cutting. Depending on the width of the cut and the quality of the surface after machining, the tool size is selected. The diameter of the particles attached to the tool is also proportional to the diameter of the tool head. The main oscillations of the tool in the three axes X, Y, Z. In this research, for the T-shape diamond tool as shown in Figure 1a, the Y-axis is the direction of depth of cut. Rotation of A and B axes affects of carving arcs and curves on the object. Materials to make jewellery are selected as sapphire, quartz, marble with high brittleness, the size of the processed products is determined within 60x60x60 (mm<sup>3</sup>). Due to the processing of brittle materials with high hardness, the process is carried out according to the principle of abrasive machining, so the required rotational speed of diamond tools is usually very high, in range of 8,000~12,000 RPM. Due to the characteristic shape of the diamond tool and the high spindle speed, the tool holder is arranged horizontally, parallel to the origin (rotation) plane. The requirements for machine design parameters are described in Table 1

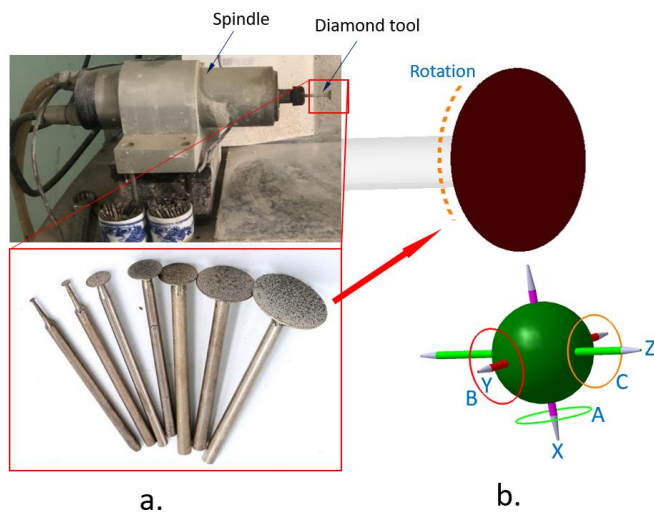

**Figure 1:** Machine table with spindle used for gemstone carving; a. Shapes of the diamond tools; b. Movement model of the sample in the process of carving

**Table -1:** Required kinematic mechanism of machine

Components	Value
X, Y, Z linear motion	100 mm
Rotation angle of A axis	180°
Rotation angle of B axis	360°
Spindle speed	0~18.000 RPM
Cutting tool size	$\phi(3\sim6)\text{mm} \times 60\text{mm}$
Material size	60x60x60 (mm <sup>3</sup> )

## 2.2 Material

From the design parameters, components and main parts are first selected. The manufacturing of CNC machines is based on the main components, existing systems and parts, and then developing new systems according to using requirements. In this study, the main components are selected as shown Table 2.

**Table 2:** Parameters of chosen components

Components	Parameters
Step motors (X, Y, Z)	Nema23/1.8, $\phi 57$ mm
Step motors (A, B)	Nema23/1.8, $\square 42$ mm
Spindle motor	SHANYU 500W; ~ 100VDC
Step motor driver	TB6600, 0.5~5A
Linear motion	Ballscrew, pitch 5mm/rev
Timing belts	GT2, D110mm & 420mm
Controller	MACH3 USB V2

Stepper motors are used for machine drive applications that is required for working accuracy. Nema MY23HY stepper motor is a stepper motor with step angle of 1.8°, high accuracy (5%), low inertia force is a type of motor with unipolar mode used as a motor for axes. Stepper motor has a frame size of 57 by 57, inductance 25 mH. When controlling, the higher the output voltage, the higher the torque transmission. Controller BOB MACH3 USB V2 circuit having a

USB in-interface that is easy to use with current computers. This circuit board communicates with the computer via USB, power used: 5VDC USB, maximum pulse frequency: 100Khz, control five stepper motors through the axes named X, Y, Z, A, B, with 5 inputs, 4 outputs, isolated IC buffer, PWM pulse output with spindle speed control.

## 2.3 Machine design

The machine design includes the mechanical system and the electrical system. In the mechanical part, the component assemblies need to be structured to ensure stability and transmission in limitation. The machine frame connects the machine parts and the shaft to ensure precise, flexible and coherent movement between the drives to form the most complete system. Based on the kinematics as described in Figure 1. The spindle and movement of axes are positioned in the appropriate directions.

For mechanical system, Inventor software is used to build, simulate and analyze the components. The 3D CAD model of the CNC machine is depicted in Figure 2. In this design, X, Y, Z axes are driven by stepper motors through the ball screws. A and B axes are driven from the stepper motors through timing belts.

The original design was based on commercially available parts, other components were redesigned to meet the using functions. In which, A and B axes are calculated to ensure strong linkages and bring efficiency when the machine is in operation. First, it is necessary to select the hard machining materials, the timing belt transmission is used to reduce the torque of the motor, and then calculate dimension, the transmission ratio between the dynamics. Full CNC machine structure is assembled through the 3D CAD simulation sketching stage as shown in Figure 2. Simulations of axis motion are carried out, re-size the parts and then machining.

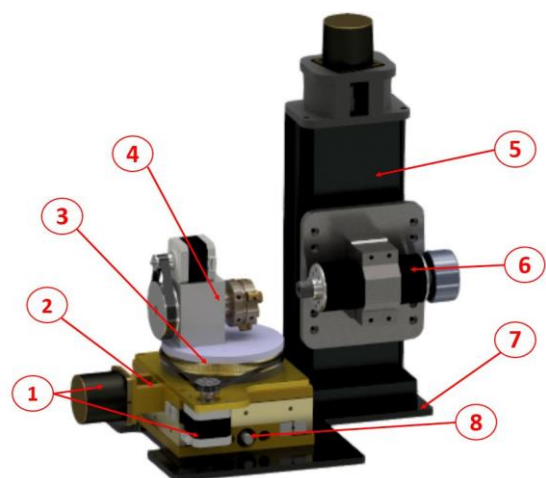

**Figure 2:** CAD design of CNC machine; 1. Step motors, 2. Z-axis, 3,4. Rotational axis (A,B), 5. Y-axis, 6. Spindle high speed motor, 7. Machine base, 8. Screw of X-axis

The electrical system has been designed and installed. The power supply for the controller and the motor is a DC source

with 03 voltage levels. In which, 5VDC is used to provide input for signals and controllers, 24VDC is used for operating Step motors, and the power source can be adjusted in range of 12~100VDC for the control speed of the spindle. The electrical diagram of the CNC machine is shown in Figure 3.

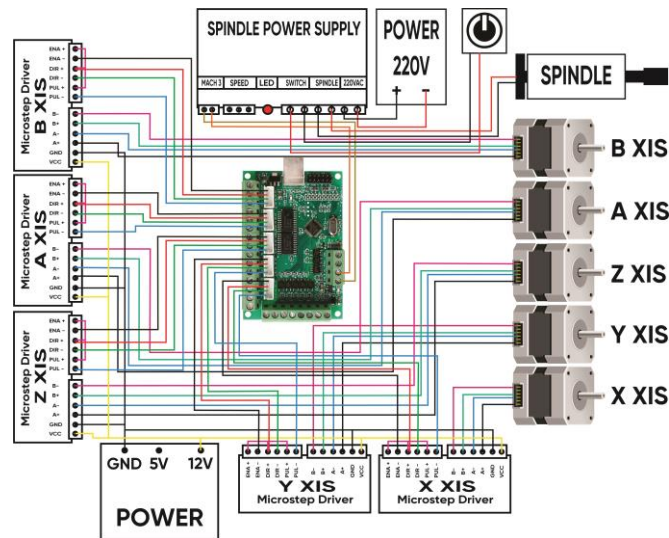

Figure 3: Electric diagram of CNC machine

### 3. SOFTWARE SETTING

#### 3.1 Setting control on Mach3

Currently, there are many kinds of software used for control CNC machines. In this study, Mach3 software of ArtSoft was chosen because of its diverse functions to declare and adjust parameters. Workflow simulation is clear and saves cost in machine building and today has become the most versatile business control software in the industry. There are two types of motions on the CNC machine, which are the linear motion of the X, Y, Z axes and the rotational motion of the A and B axes. Mach3 also aims to determine the pulse frequency fed to the stepper motor that corresponds to the actual travel length of the slide on the CNC machine. To proceed, we need to calculate the gear ratio from the stepper motors to the reciprocation of the X, Y, Z axes. Calculate the gear ratio from the step motor to the rotation of the A and B axes. Next step by determining the rotation angle of the motor per step. Finally, determine the number of control pulses of the driver. The formula for the X, Y, and Z axes is described in terms of Eq. (1) for A and B axes described in terms of Eq.(2)

$$S_l = \frac{360}{m \times \lambda \times \alpha} \quad (1)$$

$$S_r = \frac{z_2 \times 360}{\lambda \times \alpha \times z_1} \quad (2)$$

Where  $m$  is the pitch of the ball screw (5mm/rev),  $\alpha$  is the rotation angle of 1 step on all motors is the same at  $1.8^\circ$ ,  $\lambda$  is the number of micro pulses supplied to the step motor set to 1/8,  $z_1$  và  $z_2$  is the number teeth of the driving gear and the

driven gear. In curent design,  $z_1(A) = 16$ ,  $z_2(A) = 105$ ,  $z_1(B) = 36$ ,  $z_2(B) = 205$ .

The CNC machine controller is then connected to the computer, the machine configuration settings from the Mach3 software are performed in step by step. Stepper, velocity, and acceleration parameters of the step motors were defined and set up on the software. Parameters were set and checked to ensure that the motion of the axis is smooth, fast, low inertia and noiseless. Mach3 has a built-in stepper determination application for axes motors by comparing axes displacement with input commands [11]. Interface of Mach3 software on the CNC machine after fabrication is shown in Figure 4

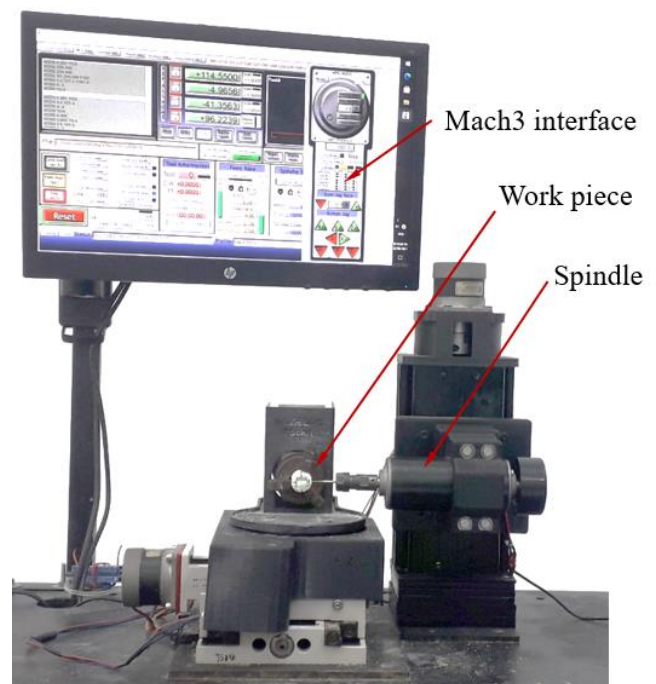

Figure 4: Mach3 interface and structure of CNC machine after fabrication

After setting the parameters for the stepper motor, the machine is run to test and check the error of the input code and the actual feed on the axes. The test was implied by micrometer with scale in range of 0-10mm and resolution is 0.01mm brand 2046S – Mitutoyo as shown in Figure 4. Check the accuracy of reciprocating movement of each X, Y axis, Z and rotation of the A and B axes to check the reciprocating motion and compensate for the motion errors. Check the accuracy of the motion of axes by move one way and by move then turn. Each test level was repeated three times to check the standard deviation. These errors was been analyzed for correction of step control. The test results show that the minimum average error is 0.002 in the X and Y axes, the error is only 0.001 in Z direction. The error level is so stable, it can be accepted for machining.

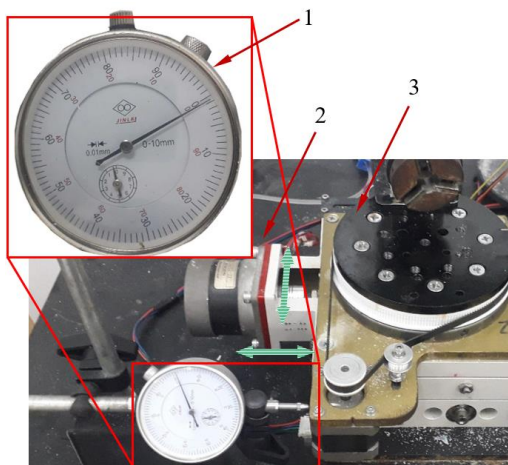

Figure 5: Test movement of axes

### 3.2 CAD/CAM/CNC on Fusion 360

The selected software for machining simulation and outputting G-Code for CNC machines is Fusion 360. This software has features suitable for the machine such as the declaration of machine parameters including machine size, capabilities, the workpiece size limitation (Workpiece), structural kinematics, G-code compiler software (Post Processing), operation of the auxiliary axes. The process of setting parameters of the CNC milling machine on Fusion software follows Figure 6.

The most important part of the configuration setting is the declaration of the kinematics structure and the G-Code compiler (Post Processing) in which the structure declaration follows the steps shown in Figures 6. In the Kinematics section, declare the auxiliary axes so that the software can recognize the machine configuration and the relation of the axes. In the Post-processing section, setting up as follows: (1) Post Location, choose System and in (2) Post-Processor choosing "acramatic.cps". This is the appropriate structure for the machine to generate G-code. Setting post processing in Fusion 360 is shown in Figure 7.

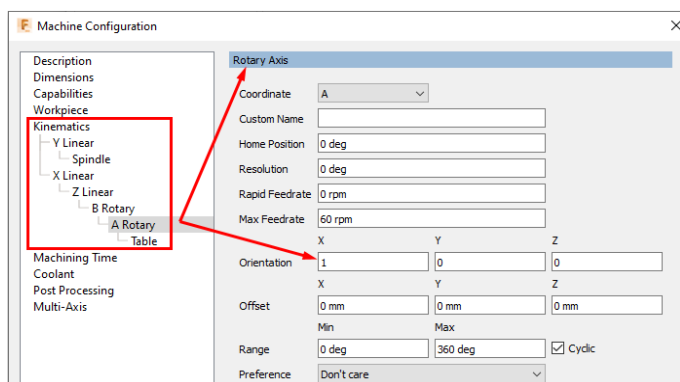

Figure 6: Machine configuration on Fusion 360

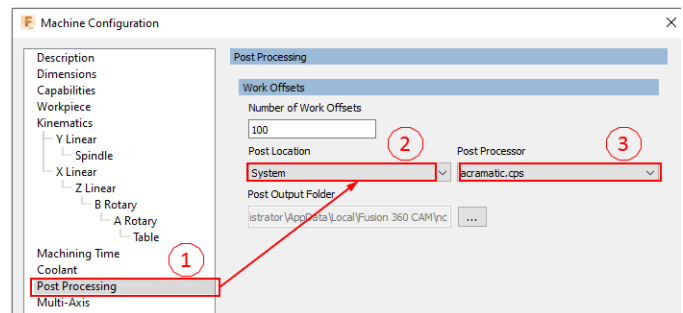

Figure 7: Setting post processing in Fusion 360

After setting up all necessary parameters, simulations of machining then were performed with some 3D CAD models to trace the tool paths to identify where to be machined and where not to be machined to ensure safety and accuracy. Next, set up different milling operations (pocket, parallel, 2D contour,...) for roughing. The appropriate shape of the tool will be declared. If the tools are not in the tool library of software, a profile can be created and added to the library. According to parameters such as height, tolerance of each pass, the toolpath is then created and converted to Post-Processing in a format that can be read by the CNC machine.

### 4. RESULTS AND DISCUSSION

In order to evaluate the performance of the machine, the workpieces made of wood, plastic, mica, and then marble were selected for testing, respectively. The test results show that the machine works well on these materials; the machine adapts with many sizes of T-shape diamond tools. The machining process of marble is shown in Figure 8. The process starts with 3D CAD design and generating G-Code in Fusion 360, as shown in Figure 8a. G-code was exported to Mach3 for machining the marble workpiece. The rough products as shown in Figure 8b. Finally, the workpiece was cut and polished. The finished products were shown in Figure 8c.

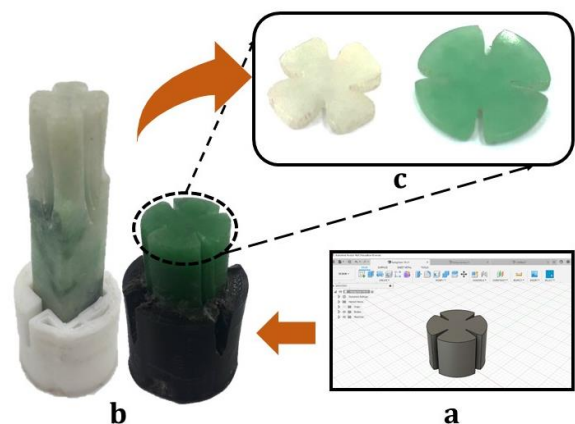

Figure 8: Marble was machined by CNC machine; a. 3D design on CAD; b. Rough products; c. Polished products

The shape and size of the final products have quite fit to dimension in CAD design. It can be concluded that using a

CNC machine to carve on the gemstone surface becomes more simple. However, setting parameters of the diamond tools is very important for G-code generating. Gemstone is a hard and brittle material, so cutting speed, feed of cut was considered more carefully. During machining process, it was shown that the position of the spindle shaft horizontally not only ensures that the tool shaft is not reversed when the cutting edge of the diamond tool acts in the workpiece and is suitable for drip irrigation.

Regarding the mechanical structure, it can be seen that the machine has working space is large, it is easy to replace the diamond tool as well as setting the workpiece and the cooling water. However, chip and dust collection system needs to be considered and conducted in further research.

## 5. CONCLUSIONS

This paper has described the process of design and fabrication of the mini 5-axis CNC machine. The process of machine configuration declaration on Fusion 360 software has been presented and discussed. The machining process of marble has been performed for jewellery making. Experiment results show that the machine works well with T-shape diamond tools for carving brittle materials. Research results can be applied to design and optimize jewellery production.

## ACKNOWLEDGEMENT

The authors would like to express their acknowledgement the fully financial support from Tra Vinh University under (317/HĐ.HĐKH-ĐHTV).

## REFERENCES

1. Fauzi, M.S.B., Development of Laser CNC Machine Structure, in Mechanical Engineering 2013, UNIVERSITI MALAYSIA PAHANG p. 1-54.
2. J.Madekar, K., et al., Automatic mini CNC machine for PCB drawing and drilling. International Research Journal of Engineering and Technology, 2016. **03**(02): p. 1106-1111.
3. Rocha, P., R. de Souza e Silva, and M. Tostes, Prototype CNC machine design. 2010.
4. Jousselin, B., Y. Quinsat, and C. Tournier, A 5-axis pocket roughing strategy reducing the remaining material volume. Procedia CIRP, 2019. **82**: p. 368-373.
5. Kim, B.-S., S.-K. Ro, and J.-K. Park, Development of a 3-axis desktop milling machine and a CNC system using advanced modern control algorithms. International Journal of Precision Engineering and Manufacturing, 2010. **11**(1): p. 39-47.
6. Sriranga V Deshpande, et al., Design and fabrication of 3-axis CNC Milling machine. International Journal of Engineering Research and General Science 2018. **6**(4): p. 34-38.
7. Sathyakumar, N., et al., A Build-Your-Own Three Axis CNC PCB Milling Machine. Materials Today: Proceedings, 2018. **5**(11, Part 3): p. 24404-24413.
8. Brecher, C., et al., Compact design for high precision machine tools. International Journal of Machine Tools and Manufacture, 2010. **50**(4): p. 328-334.
9. Gupta, V. and P.M. Pandey, In-situ tool wear monitoring and its effects on the performance of porcine cortical bone drilling: a comparative in-vitro investigation. Mechanics of Advanced Materials and Modern Processes, 2017. **3**(1): p. 2.
10. Gäbler, J. and S. Pleger, Precision and micro CVD diamond-coated grinding tools. International Journal of Machine Tools and Manufacture, 2010. **50**(4): p. 420-424.
11. Mach3 CNC Controller Software Installation and Configuration, A. USA, Editor. 2008: The Mach Developer Network.