

Poka-Yoke for Missing of Child Components and Ok Stamping on Part of a-Pillar

Swapnil D. Nehe¹, Patil Harshal², Zambare Somnath³, Yadav Prashant⁴, Badhan Piyush⁵

¹Student, Mechanical Engineering, K.K. Wagh college of Engineering and Research, Maharashtra, India

²Student, Mechanical Engineering, K.K. Wagh college of Engineering and Research, Maharashtra, India

³Student, Mechanical Engineering, K.K. Wagh college of Engineering and Research, Maharashtra, India

⁴Student, Mechanical Engineering, K.K. Wagh college of Engineering and Research, Maharashtra, India

⁵Student, Mechanical Engineering, K.K. Wagh college of Engineering and Research, Maharashtra, India

Abstract - In profile view, pillars are the vertical or almost vertical supports of a car's window region, labelled as the A, B, C, or (in larger cars) D-pillar, progressing from front to back. As we all know, human interaction introduces a significant amount of mistake. When the A-Pillar upper portion was ready for quality control after assembly, the quality control process was done manually.

Key Words: Poka Yoke, Quality Management, A-Pillar, D-pillar, fatigue.

1. INTRODUCTION

In profile view, pillars are the vertical or almost vertical supports of a car's window region, labelled as the A, B, C, or (in larger cars) D-pillar, progressing from front to back. The alphabetical identification of a car's pillars gives a common point of reference for design debate and critical communication. Rescue crews, for example, use pillar nomenclature to make communication easier. When employing the Jaws of Life to hack up crashed vehicles. The A, B, and C pillars, which are positioned at the front, centre, and rear of a conventional family saloon, are normally three vertical support pillars. Larger vehicles, such as estate cars, may include a fourth pillar called a D Pillar. The primary purpose of these pillars is to provide additional support to the winch.

2. A-Pillar:

The A pillar is normally a closed steel structure welded to the car's rocker panel and floor pan at the bottom, as well as the roof rail or panel at the top. The roof and door design of a car are the most expensive body components to build or re-tool, and they are a crucial element in achieving safety and crash regulations. Slimmer, chamfered windscreen pillars, known as "A" pillars, are used in some designs to help improve driver vision (and hence reduce blind spots). The center or B-pillar, as "possibly the most complicated of all the components on the vehicle," may be a multi-layered assemblage of varied lengths and strengths. The 'A' pillar is a structural component of a vehicle that runs from the roof to the floorboard and connects the windshield and front door to the vehicle's body. The issue is with the interior trim of the 'A' pillar. These trim pieces are made of plastic and are

based on original GM tooling. They begin at the lower interior dash of the windshield and end above the windshield. This interior trim has a small parts assembly of pins and foam called Child Parts on it.

2.1 Existing Problem

Human interaction is required during the assembly of A-Pillar U321. When the A-Pillar part is sent to be assembled with the kid parts, the process is manual. Some kid components may be missing due to worker inattention or fatigue, and because the quality inspection process is manual, there is a risk of picking a poorly built A-pillar due to human participation.

2.2 Methodology

"Methodology" is a systematic approach for realization of total task. It consist of following details.

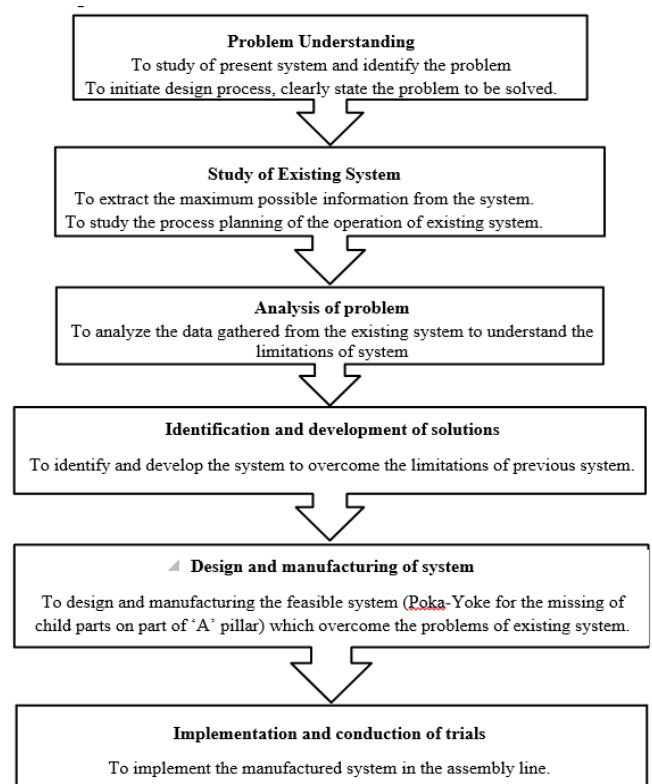

3. Existing Problem

A-Pillar takes two personnel to assemble because it is a manual product. All pre-requisite quality checks have been completed. Four clips on each side of the A-Pillar are assembled, followed by the installation of four foams materials on the A-Pillar. After complete assembly, the assembled part is delivered to the inspection department, where it is checked for appropriate fitting and part position. If the part does not match the idle part, it is sent back for rework, and if it does, it is moved to the packaging and dispatch area.

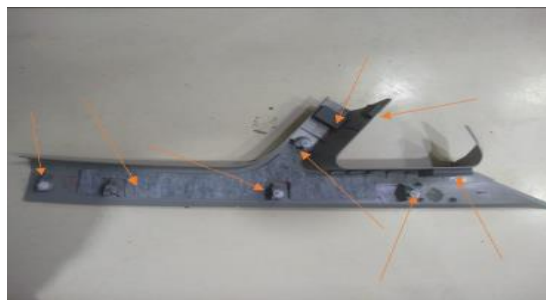
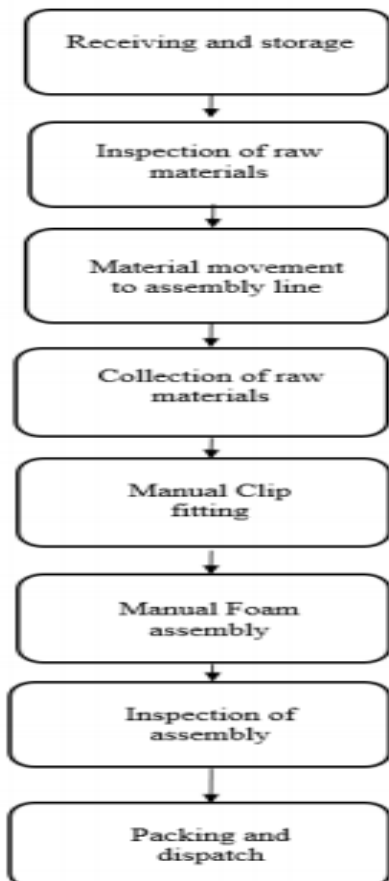

Fig3.1. 'A' Pillar U321 Part with Assembled child parts

3.1 Existing Process Flow



3.2 Study of existing system

The A-pillar is put together by hand. The A-pillar is assembled online by two workers at a time. After obtaining the raw material, it is first inspected for quality control before being sent to the online area for assembly. For this purpose, four clips from the left and right sides are assembled, followed by the installation of four foam materials. A-Pillar has been completed.

After complete assembly, the assembled part is delivered to the inspection department, where it is checked for appropriate fitting and part position. If the part does not match the idle part, it is sent back for rework, and if it does, it is forwarded to packaging and dispatch section.

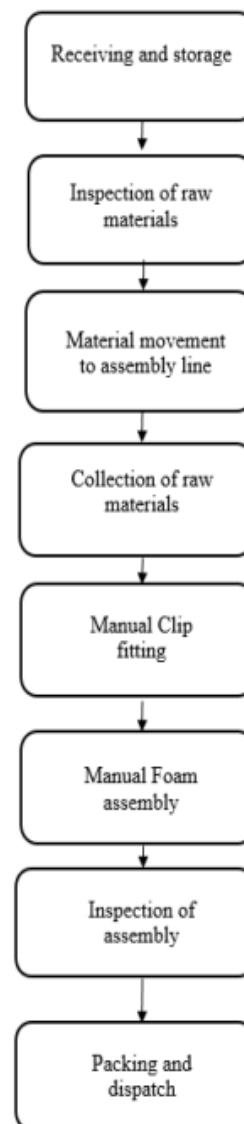

Fig3.2.1: Process flow for A pillar assembly

3.3 Analysis of problem

In the problem analysis, elements such as missing A-Pillar Lower kid parts, inspection time and manual error in A-Pillar testing, manpower necessary for A-Pillar checking, manual

intervention or worry in the choice of whether to accept were considered. Consider whether to accept or reject the part, as well as the assembly process' productivity. The disapproval The A pillar's information is likewise gathered.

Sr. No.	Project	Part Name	Apr. 19	May. 19	Jun. 19	Jul. 19	Aug. 19	Sep. 19	Oct. 19	Nov. 19
1	U321	A Pillar Lower LH								
	Rejection	Details								
1	Customer Complaint		1	1	2	0	1	0	0	0
2	Final Rejection		7	5	4	4	5	3	2	0

Table1. Rejections Details

3.4 Identification and development of solution

After reviewing and weighing all aspects, the option could be to build a system that ensures proper assembly of the A Pillar U321 part. As a result, the Poka-Yoke technique is the most commonly employed to eliminate human errors and reduce rejections. The application of automation furthermore, mistake proofing decreases or eliminates risk in the workplace. By preventing problems at the source, you can speed up the process. Using error-proofing software or Most detection controls are more expensive than error proofing devices. The following are some examples of the stages for putting the Poka-Yoke technique into action.

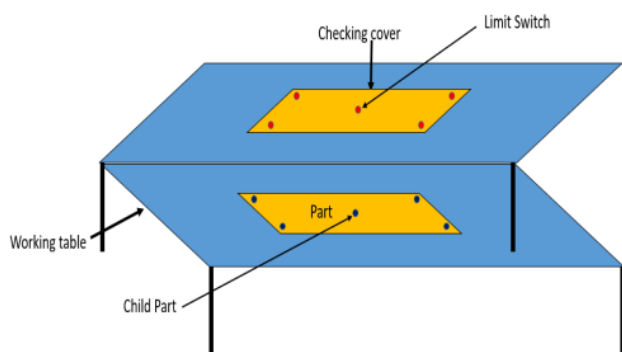

Fig3.4.1: Rough Schematic of Poka-yoke

4. Concept

Three limit switches are inserted in drilled holes in the fixture's hollow. Limit switches are triggered after a part is placed in a fixture cavity, causing the part to lock in place and the operator to be unable to remove it until the full assembly of the fixture is completed. The checking cover is pushed on the part by lowering the hinge after all of the child pieces have been assembled. The checking cover is the same as the 'A' pillar U321. The limit switches are positioned in

the same area as the kid parts in the checking cover. As a result, when only the limit switches will actuate if the checking cover is lowered or pressed on the main section. When all of the child parts have been assembled in their proper places. If a child part is missing from the assembly, the limit switch for that part will not actuate, and the circuit will not be completed. As a result, the part will not be unlocked by the fixture, and the operator will be unable to remove the part from the fixture. Even if the operator makes an attempt to remove the fixture. If you aggressively remove the part, it will be damaged. After pushing the checking cover on the part and completing the circuit, the circuit will complete and the part will be punched with an OK stamp, allowing it to be unlocked. There will be no inspection work as a result of all of this.

4.1. Design and manufacturing of system

Steps involved in design of Poka-yoke fixture are as below:

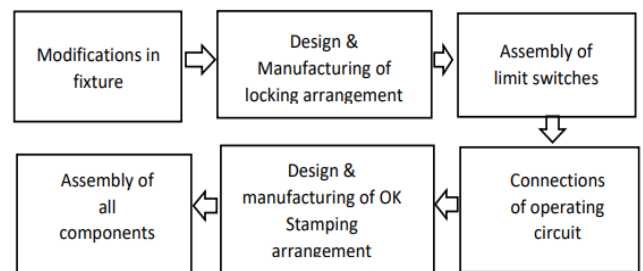

Fig4.1.1. Steps in design and Manufacturing of Poka-Yoke fixture

4.2. Low cost automation

The design and implementation of technology to monitor and control the production and delivery of products and services is known as automation. In today's environment, any industry that wants to stay competitive must invest in automation. 'Automation' is defined as a collection of actions aimed at replacing human labor with machines and utilizing technology to do it. Storage Systems, Handling Systems, Assembly Lines, Production Lines, Production Cells, and other areas of automation are included.

Machines, computers, controllers, and software, among other things This necessitates a significant financial expenditure.

5. Description of Poka-yoke system of Project

This error-proofing circuit is designed specifically for A pillar U321. This is a simple automation circuit with a minimal cost. Limit switches are utilized to create a circuit in this system. The locking mechanism, which consists of a rack and pinion and a pneumatic actuator, is bolted to two opposing walls.

1.Limit Switches	A limit switch senses an object's physical movement by making direct touch with it.
2.Switched-mode power supply	A switched-mode power supply is an electronic power supply that incorporates a switching regulator to convert electrical power efficiently.
3. 5/2 Directional control Valve	A spool inside a cylinder that is mechanically or electrically activated is typical of DCVs. The spool's location determines whether flow is restricted or allowed. There are five ports and two directions on it.
4. Pneumatic actuator	Pneumatic cylinder are mechanical devices which use the power of compressed gas to produce a force in a reciprocating linear motion. Like hydraulic cylinders, something forces a piston to move in the desired direction.
5. Rack and pinion	A rack and pinion linear actuator is made up of a circular gear and a linear gear that work together to convert rotational motion into linear motion.
6. Fiber Reinforced Polymer fixture	It is made from FRP material (Fiber reinforced plastic). The part on which the operation is to be done is placed on FRP fixture.
7. MS Bracket or supporting Frame	The fundamental structure of this project is a mild steel bracket. With nut and bolt systems, the checking cover is secured to the bracket levers.
8. Checking Cover	Checking cover is nothing but the same part as 'A' pillar U321. On checking cover limit switches are attached at same location as that of child parts.

6. Working of Poka-yoke system

Three limit switches are inserted in drilled holes in the fixture's hollow. Limit switches are triggered after a part is placed in a fixture cavity, causing the part to lock in place and the operator to be unable to remove it until the full

assembly of the fixture is completed. The checking cover is pushed on the part by lowering the hinge after all of the child pieces have been assembled. The checking cover is the same as the 'A' pillar U321. The limit switches are positioned in the same area as the kid parts in the checking cover. As a result, when only the limit switches will actuate if the checking cover is lowered or pressed on the main section, when all of the child parts have been assembled in their proper places. If a child part is missing from the assembly, the limit switch for that part will not actuate, and the circuit will not be completed. As a result, the part will not be unlocked by the fixture, and the operator will be unable to remove the part from the fixture. Even if the operator makes an attempt to aggressively remove the part, it will be damaged. After pushing the checking cover on the part and completing the circuit, the circuit will complete and the part will be punched with an OK stamp, allowing it to be unlocked. There will be no inspection work as a result of all of this.

6.1 Selection of components

Locking arrangement consists of following components:

- 1) Rack and pinion
- 2) Pneumatic actuator
- 3) Directional control valve(DCV)

7. Circuit Diagram

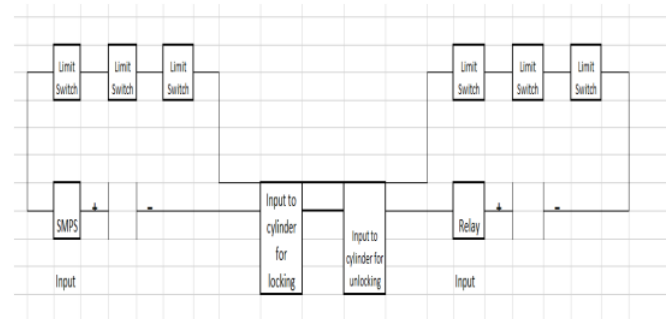

Limit switches and pneumatic-based error proofing are the most cost-effective and widely applicable way for detecting mistakes that involve pneumatic components.

8. Conclusion

- 1) The Poka-yoke system is an electro-mechanical device that is used in the quality control process to entirely eliminate the acceptance of substandard items.
- 2) For approved parts, there will be auto-certification by poka-yoke. As a result, there will be no human intervention in the decision to accept or reject a portion.
- 3) Poka-yoke enables low-cost inspection automation by removing or reducing human influence to a large extent.
- 4) When this poka-yoke is used in the quality control process of inspecting the lower half of a 'A' pillar with a poka-yoke, it eliminates the possibility of accepting a faulty 'A' pillar.

5) When no substandard items are accepted, the company's market reputation increases.

References

[1] Dr.Nanjundaraj Premanand, "Study on implementation of Poka-Yoke technique in improving the operational performance by reducing the rejection rate in the assembly line", International Journal of Pure and Applied Mathematics, Volume 119 No. 17 2018, 2177-2191.

[2] Dr.R.Vinayagasundaram, "Implementation of Zero defect through Poka-Yoke approaches in the assembly line of compressor manufacturing industry", International Journal of Pure and Applied Mathematics, Volume 119 No. 17 2018, 2319-2332.

[3] Vicky Pravin Poladia, "A Review on use of Mistake Proof (Poka Yoke) Locating Fixture on Ultra SD Cartridge Assembly Line", International Journal of Advanced Engineering Research and Science, Vol-4, Issue-1, Jan- 2017.

[4] V.K. Kannan, "Guidelines to Implementation of Poka yoke in an Assembly Line", Journal of Chemical and Pharmaceutical Sciences, ISSN: 0974-2115.