

Design and Fabrication of Bladeless Wind Power Generation

N. Sai Charan¹, A. Sai Vasudev²

Department of mechanical engineering, MLR institute of technology and management, Hyderabad, Telangana-500043

Abstract - India is now pursuing its goal of becoming an all-encompassing powerhouse. This suggests that in terms of economic development, it is at the top of the list of developing nations. As a result, the nation's energy requirement will rise quickly. The current energy generating methods are less cost-effective and environmentally unfriendly. They need significant upkeep expenses and investments. A turbine that is simple to construct, secure, quiet, cost-effective, and simple to operate is therefore urgently needed. The Bladeless wind turbine, which relies on the vortex shedding phenomenon, is one such turbine. This turbine is the ideal upgrade over the current standard turbine, which has several negative impacts. Our research intends to create a fuel-free wind turbine that can effectively replace conventional wind turbine since it is both environmentally benign and cost-effective. It makes use of a completely novel method for gathering wind energy. The hollow mast is made to vibrate at a resonant frequency, creating vortices that are later transformed into electrical energy using piezoelectric sensors. Because there are fewer moving components, there is no moving, sharp blades, the structure also provides better safety for birds flying about. Additionally, because less space is needed, more units may be put in for huge power generation

Key Words: Piezoelectric sensors, resonating frequency, vortices, vortex shielding.

1. INTRODUCTION

Over the last few decades, larger, more effective designs have generated ever-increasing amounts of electricity, making wind power a credible source of energy. Turbine growth may have reached its ceiling despite the sector seeing a record 6,730 billion in world wide investment in 2014. When compared to traditional turbines, bladeless generators will produce power for 40% less money. Due to the size of the parts, transportation is becoming more difficult with each generation. Blades and tower tones' pieces frequently needs specialized vehicles and straight, broad roadways. Moreover, wind turbines are heavy. Towers used to support gearboxes and generators can be 100 meters in height and weigh more than 100 tons.

1.1 Problem statement

Traditional windmills demand strong winds. There aren't many places at this airspeed. Hence

- Windmills that operate at lower wind speeds are urgently needed.
- The price of the various components of a traditional windmill is quite costly per kilowatt, a typical windmill will cost between \$2500 and \$7500.
- The design of a wind turbine is challenging.
- A considerable amount of space is needed for a functional windmill. The volume swept by the blades of traditional windmills is greater.
- For wind farms with a capacity of 1 megawatt, the installation area is 60 acres. Additionally, they are deadly to birds.
- Low-frequency sounds they create are harmful to human health.

2. METHODOLOGY

Alternative energy has made several unsuccessful attempts to resolve these problems. This most recent submission however, promises to use a fundamentally differently technique from the one we used in our project, which was to turn the kinetic energy of air in to physical- mechanical stress. After that we convert the mechanical pressure into an alternating impulse of charge flow, or current, using piezoelectric sensors. We employ a high structure known as the mast to saddle the active flow of air. The pole is welded to robust support at the bottom and has a diverging cylindrical form. It may be viewed as a cantilever beam that supports a load that varies consistently. The mast begins to vibrate with a certain amplitude and in a specific direction with respect to the welded junction when fast-moving air strikes it. Every substance has a natural

intermolecular frequency, as we know from the idea of resonance. Resonance happens when the frequency coincides with the frequency of the mast's vibration. The mast begins to shake more intensely, and then, using a metal plate called a disc that is welded to the permanent support of the mast, we convert the intense vibration into vertical stress on the piezoelectric sensors at the permanent mast support. Our entire piezoelectric circuit is mounted on another plate, which receives the vertical stress transfer. At this point, we have effectively Changed the kinematic energy of the air into the typical stress On piezoelectric sensors Piezoelectric sensors or chips Made of piezoelectric material, generate charge while under stress. This charge, when connected to wires, generates current

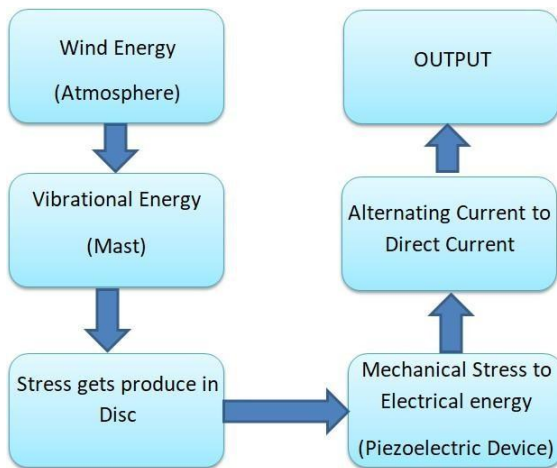

Fig -1: Step by step process

2.1 Components

The major parts that are effectively employed in the design and the fabrication of the Bladeless wind power generation are described below:

The main parts of the BLWPG are:

1. Mast.
2. Disc Plate.
3. Piezoelectric device
4. Spring.
5. Voltage Regulator.
6. Wire Connection.
7. Bulb

3. DESIGN OF BLADE LESS POWER GENERATION

3.1 CAD MODELLING

Analytical calculations were utilized to estimate the pieces dimensions, which were then employed in modeling. The CATIA V5 programs is used to produce the CAD model. Any FEA analysis correctness is based on how well the modelling process and meshing number were executed. The CATIA V5 programme models the parts using the dimensions shown below

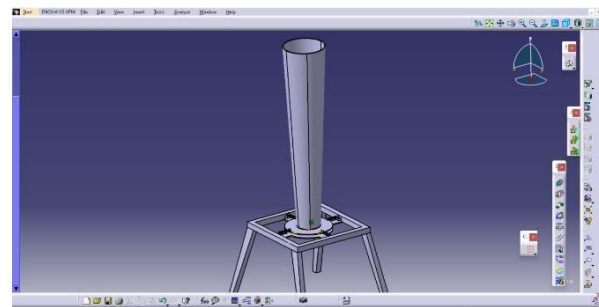

Fig -2: 3Dview of BLWPG CATIA assembly

3.1.1 Mast

The building is made of carbon and fiber glass and is lightweight. The conical-shaped portion is the component that oscillates in the middle. The smaller weight will cause the oscillations to be greater.

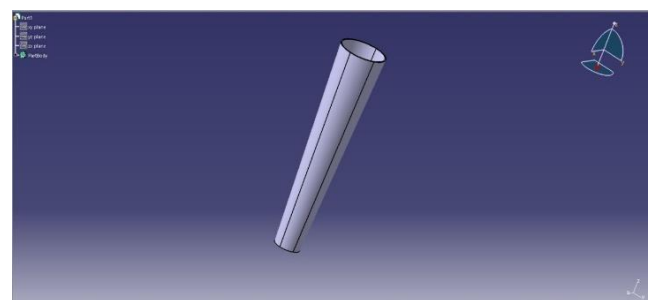

Fig -3: Isometric view of Mast

3.1.2 Disc Plate

Iron discs shaped into two circles are utilized. The piezoelectric chips are placed on one of the discs, while the other disc has a welded mast that is utilized to apply the generated stress to the piezoelectric chips uniformly.

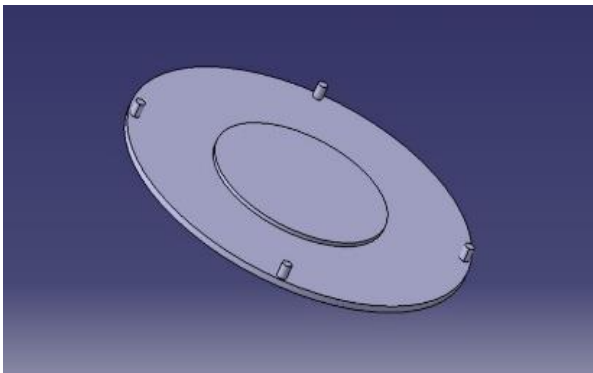

Fig -4: Isometric view of Disc

3.1.3 Spring

Four helical springs, one end of which is attached to the device's foundation and the other to the circular disc. They are employed to provide the mast both constraint motion and vibratory motion.

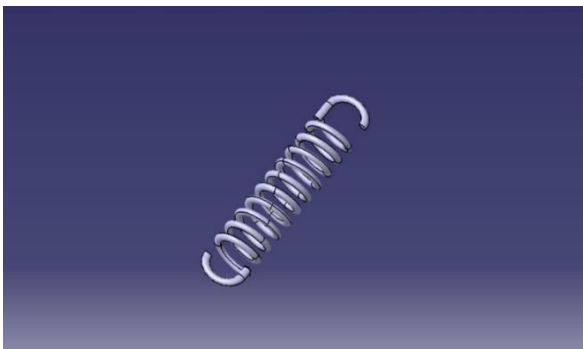

Fig -5: Isometric view of spring

4.1 Piezoelectric Device

Quartz crystal is the main component of piezoelectric plates. Applying force causes deformation, which generates an electric signal. It is reversible. A mechanical stress applied will produce a voltage, and a voltage applied will somewhat alter the form of the solid (up to a 4% change in volume). Inverters must be used if piezoelectric materials are to be used for energy production. DC voltage is generated by piezoelectric materials. Therefore, in order to use it, we must convert it to AC voltage. The inverter will experience some power loss.

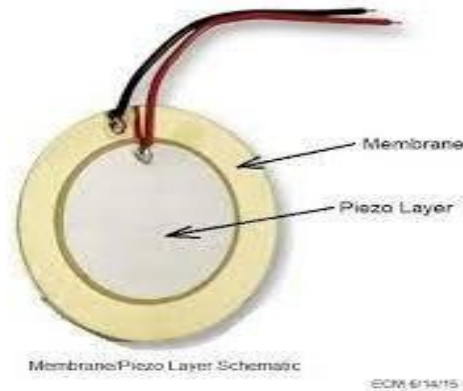

Fig -6: Piezoelectric device

4. NUMERICAL ANALYSIS

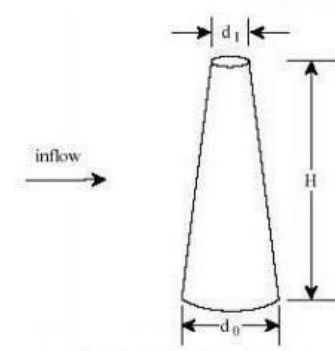

Fig -7: Tapered cylindrical structure

- Larger Radius of the mast,
 - $R_1 = 0.10 \text{ m}$
- Smaller Radius of the mast,
 - $R_2 = 0.04 \text{ m}$
- Height of the mast,
 - $L = 1 \text{ m}$
- Lateral Surface area of the mast (open),
 - $S = \pi \times (R_1 + R_2) \times L$
 - $= 3.14 \times (0.10 + 0.04) \times 1.00$
 - $= 0.4392 \text{ m}^2$
- Average Velocity of the wind,
 - $v = 30 \text{ to } 40 \text{ km/h}$
- Projected area of the mast exposed to wind,

$$A = (R_1 + R_2) \times L$$

$$= 0.1400 \text{ m}^2$$

- 3. To see the interior working of the mast clearly Hide the faces.

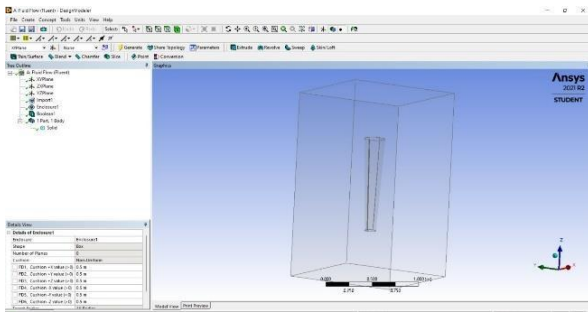

Fig -10: Four face box created

- Two faces identified as Inlet and outlet in the domain.

Check if the mast can support itself by passing 40m/s of air through the intake.

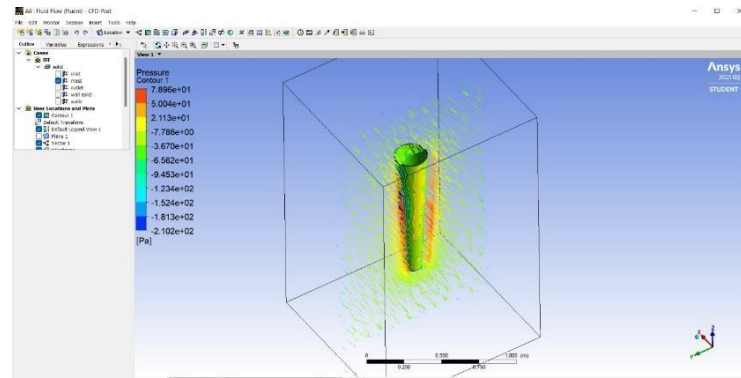

Fig -13: Counters of velocity magnitude

- The velocity magnitude distribution reveals that the air flowing through the MAST is moving at a higher velocity at the upper surface than at the lower surface, which would exert the required force on the MAST.
- Air has a free stream velocity of 40 m/s.

6. MANUFACTURING PROCESS

The processes used in manufacturing are those that turn raw resources into finished goods. The manufacturing process starts with the development of the raw materials from which the planning is generated. The last step involves applying manufacturing processes to turn these materials into the required component. During the production process, the fabric may be treated (by means of heat treatment or coating), machined, or reshaped. Planning the assembly process before manufacturing as well as testing and inspections for quality assurance are all part of the manufacturing process.

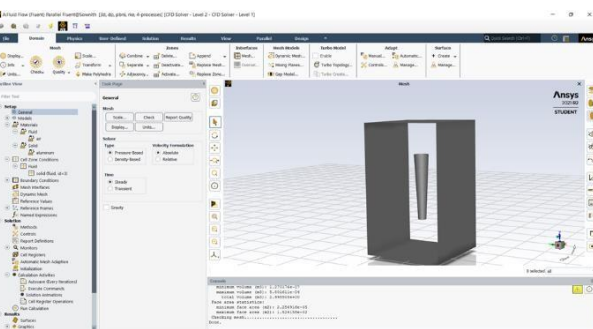

Fig -11: Two face domain

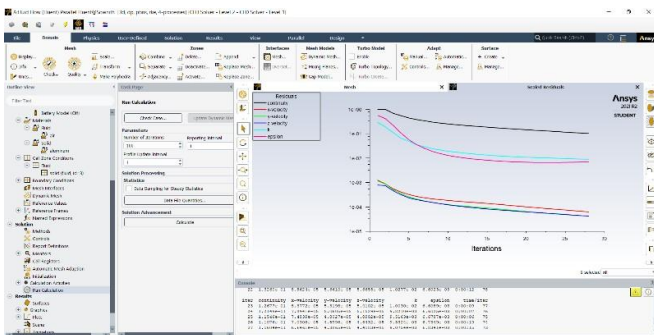

Fig -12: Residual sim

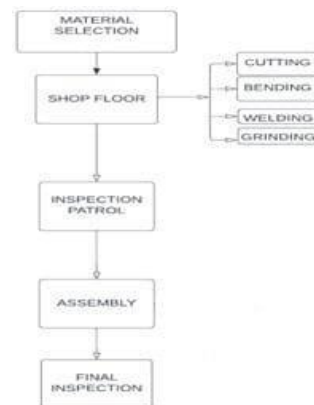

Fig -14: Manufacturing process of BLWPG



Chart -15: Parts of BLWPG



Chart -16: Assembly of BLWPG

7. RESULT & DISCUSSION

According to the outcome of the numerical study, there is a net force of 11.93N operating in the Z direction on the mast.

The greatest average wind speed or 40km/hr. was used in this estimate.

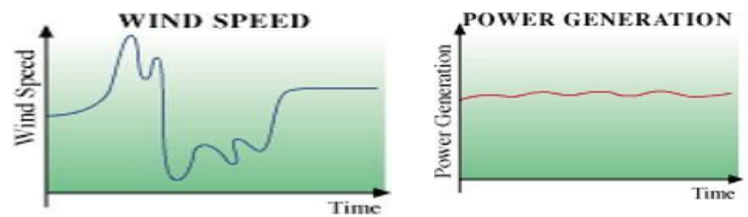

Chart -1: Variation of wind speed and power generation with time.

The wind speed changes significantly, as indicated in the above chart, and as a result, thenet force acting on the mast varies, producing oscillations with various frequency. The piezoelectric chip are subjected to variable amounts of stress as a result of these random oscillations, which later produces an alternative current. Therefore, to provide a stable power output, we employed a full-wave rectifier. This results in the steady power flow seen in the above image.

8.1 Advantages

- Additionally, the frequency of oscillation that a structure may have is understood to be finite, which reduces the possible number of working hours. However, it can function over a larger range of wind speeds because of a self-tuning magnetic coupling mechanism.
- By automatically varying stiffness and "synchronising" with the speed of the incoming wind, this technology enables oscillation amplitudes to be maximised while maintaining resonance without mechanical or human intervention. Because there are no mechanical components in the design that may be damaged by friction, maintenance costs should be reduced by around 53%.
- The magnetic force of repulsion increases as wind speed increases, which shortens the distance between the rod and the magnet. As a consequence, the oscillation and potential of the energy produced reach their peak. As a result, it can save money over the course of the multi-blade wind turbines' 20-year lifespan by eliminating oil changes and the replacement of the majority of its mechanical parts. Of course, weariness still affects it.
- In particular, the elastic rod in the bottom part of the structure, which must endure larger stresses, is susceptible to twisting and displacement from the wind. However, research conducted by the corporation supports the fact that the stress on the rod is much beyond the carbon fiber's operating capabilities.

- The elastic rod at the bottom of the structure, which is subject to greater loads, is particularly vulnerable to twisting and displacement by the wind. The corporation's own research, however, demonstrates that the tension placed on the rod is significantly greater than what the carbon fibre can withstand.

- The installation's operating lifespan is predicted by computational modelling to last between 32 and 96 years. It presently occupies up to 30% of the space of a typical generator and has a top-end maximum amplitude of around. At the same height as many contemporary wind turbines, it can absorb roughly 40% of the wind energy present in the atmosphere, which is a more than reasonable capability.
- Because the design is so focused on preventing wear and tear, the system does lose some electrical conversion capability (hitting 70% of the yield of a typical alternator).
- A "greener" wind alternative is what the Bladeless Turbine aspires to be. Because it doesn't require the same kind of motion or movement of the same size as a conventional wind turbine and allows for greater visibility, the effect on the avian population is anticipated to be significantly reduced. Future wind farms may be made fully silent by lowering the oscillation frequency of the equipment down below 20 Hz, where it is non-existent. The SEO Birdlife Association is among the environmental advocacy groups that support it since it neither kills birds nor produces noise.

8.2 Disadvantages

The fact that bladeless wind energy is still a developing technology and depends on investors taking a chance seems to be its major drawback. Of course, this phase is necessary for all new technology. is more maintenance-intensive due to the gear systems used. Comparatively speaking, the efficiency of energy taken from the wind is lower than that of a traditional wind turbine. The required of control systems for regulating oscillation to match the mast's natural frequency and regulating frequency at greater wind speeds. Depending on the power needed, the mast's height may be adjusted.

8.3 Applications

Bladeless wind energy can be used in a variety of industries and applications, including marine off-grid systems, industrial applications, remote telemetry and mobile base stations and forhouses, school and farms.

- **Bladeless energy for Agriculture:** Remote power systems are needed more and more in the world of farming. Whether it's for powering electric fencing, powering water pumping, powering lighting in stables and chicken sheds or powering underwater cameras at salmon farms.
- **Bladeless energy for Telecoms:** With more and more mobile communications and broadband technology being deployed in rural and remote areas, providing power for the transmission equipment can often be a real headache.
- **Bladeless wind energy for Off-grid Lighting:** Small scale bladeless wind turbine generators are ideal for providing efficient and reliable lighting in off-grid locations. The bladeless energy generates free renewable energy which is stored in a battery ready for when it gets dark to power public street lights, car parks and playgrounds. We can combine the bladeless energy with solar panels from our advanced solar range to ensure a continuous supply of renewable energy for a sustainable off-grid lighting solution.

9 CONCLUSION

The new strategy that has gained traction in recent years is the transformation of renewable energy into a form that can be used. This initiative aims to develop a replacement for the conventional wind turbine. The cost of this turbine is significantly lower than that of the typical bladeless turbine because piezoelectric sensors have been employed in place of the alternator and generator. The modest size of this turbine also makes it simple to install in homes, schools, and any rural location. Our turbine also has the benefit of having fewer moving components, which means less wear and tear and lower maintenance costs.

Overall, our piezoelectric bladeless turbine is cost-effective, environmentally benign, and a fresh take on the conventional method.

10. REFERENCES

- [1] World watch Institute, "Renewables 2005: Global Status Report" prepared for the Renewable Energy Policy Network, Washington DC, 2005.
- [2] U.S. Department of Energy, DOE/GO-102008-2567, "20% Wind Energy by2030," July 2008.
- [3] H. K. Lukasz, J. Hjerrild and C. L. Bak. Harmonic analysis of offshore wind farms with full converter wind turbines. 2009.
- [4] Global Demand for Graphene after Commercial Production to be says Report". AZONANO.com. 28 February 2014. Retrieved 24 July 2014.