

STUDY ON DEVELOPING MORTAR-LESS MASONRY WORKS AS ALTERNATIVE BUILDING CONSTRUCTION METHOD

Abreham Desta¹, Sasikumar Selvam¹, Behailu Zerihun²

¹College of Engineering and Technology, Construction Technology and Management, Wachemo University, Hossana, Ethiopia.

²Faculty of Civil and Water Resource Engineering, Bahir Dar Institute of Technology, Bahir Dar University, Bahir Dar, Ethiopia.

ABSTRACT

Currently there has been potential need of housing due to high rate of population in worldwide. Most of developing countries including Ethiopia, proceeding in the hopeful progress in construction methods in terms of addressing such a problem. The objective of this study was to develop the mortar-less masonry work by using interlocking hollow concrete blocks as alternative construction method to have affordable houses. Questionnaire survey was distributed and collected from respondents, and twenty seven (27) samples of the interlocking concrete blocks were used to conduct experimental works. From the analysis, HCB was ranked as the mostly used product for a masonry works of building construction in a Hossana town when compared to other materials, and currently, there has been not the experience of using interlocking concrete block for a masonry works of building construction in a town. According to the output of modeling, there are two basic models developed with the size of 200 x 200 x 400 mm, and 100 x 200x 400 mm. The maximum density achieved was 1222.73 Kg/m³ for an interlocking hollow concrete block after 28th day curing period, the maximum compressive strength achieved was 2.39 MPa (N/mm²) that the products can be categorized in the Class C according to ESC D3.301. The water absorption capacity of the product was 16.45% which is greater than the standard requirements for concrete masonry units that have to be less than 10%, which requires using a proper plastering to prevent the penetration of rain water. IHCB ranked the least cost and time required when compared to that of conventional Hollow Concrete Blocks.

Keywords: IHCB, Mortar-less masonry, Alternative building construction method

1. Introduction

Worldwide, towns and cities have grown at a rapid rate and the dramatic problems linked to this include huge shelter needs; emergence of squatter settlements and slums; and deficient infrastructure in many low-income settlements [1,2]. Currently, millions of people worldwide live in substandard housing conditions and this problem is expected to get worse. By 2025, it is estimated that the number of urban households occupying inadequate, unsafe, and crowded housing will rise to roughly 440 million [3].

The building sector has undergone a radical change in the type of building materials and methods used for urban dwellings over the past few decades in most countries. More and more often, alternative building materials are used in place of conventional and traditional building materials. The present rate of construction in developing countries including our country Ethiopia is generally sufficient to meet the needs of only 10% of the net increase in population per year [4].

So, the impact of construction methods have on productivity, quality, and cost, their selection is a key decision for the successful and sustainable construction projects, and has influence on the productivity and efficiency of construction projects [5, 6]. Therefore, achieving high productivity depends greatly on the selection of the construction methods to be employed throughout the execution of a construction [7]. Building using distinct units, frequently put in and connected by mortar, is known as masonry; the term "masonry" can also refer to the modules themselves. The mortar less masonry works by using interlocking block configurations were first developed from compressed mixtures of Portland cement, dust from industries and water [8]. Researchers developed the compressed interlocking earth blocks in developing country which is reinforced by different natural fibers, and stabilizing with cement [9, 10].

The strength is increased by 40% compared to the brick and by 20% compared to the concrete masonry hollow. Furthermore, as compared to the interlocking characteristics, the increase in compressive strength is also seen. In comparison to the prism without interlocking mortar, interlocking mortar enhances strength by 30% [11]. Considering the structural behavior of interlocking blocks, they are commonly less economic, non-loadbearing constructions. An interlocking lightweight cement block was developed to use in load bearing masonry walls. It was found that the mix proportion of constituent materials to achieve the target strength and density to be 1:1:2 of cement: sand: polystyrene beads, with water cement ratio of 0.35. The average weight of an individual block was 20.4 kg, which is an acceptable weight for a single person to handle. When compared to convention masonry block construction, interlocking blocks, which are dry, assembled, save a great deal of mortar [12].

Obviously, currently there has been a potential need for housing due to high rate of population in worldwide. Most of developing countries including our country Ethiopia, proceeding in the hopeful progress in construction methods in terms of addressing such a problem. But, in our local construction practice still there is less productivity with great wastage especially in concrete dependent works. And, it is longing to see either new creative ideas or modification of the existing method of statement that can minimize the cost and time with respective quality for building construction project nowadays in our country. So, it is the right time to assess the alternative construction methods including the development of interlocking blocks for masonry works, precast elements of building structure, modular construction system and other options that can reduce the project cost by reducing the wastes, workforces, and period to accomplish it with confirmative standard of quality.

The present study focused on developing better interlocking blocks that can reduce the mortar works to make the building masonry construction by a smaller number of semi-skilled labors with in short period of time comparatively to the existing practice of construction firms around Hossana town, SNNPR, Ethiopia. Furthermore, assessed the current practice of alternative construction methods that could be used in local firms, and determined the physical and mechanical properties of mostly feasible products,

2. Materials and Methods

2.1. Materials used

a. Cement

Dangote Ordinary Portland Cement (OPC) of grade 32.5R CEM I was used throughout this study in the preparation of the concrete mixes of the solid block according to IS 269. Based on result of experiment, the initial setting time and final setting time of Dangote OPC of Grade 32.5R I were 128.75 min and 244.5 min respectively when manual Vicat apparatus used. Both results are nearest to the value pointed on the specification of manufacturer.

b. Aggregates

Coarse and fine aggregate- Concrete disposal in Wachemo university that discharged due to floor maintenance. All physical tests were done as per ASTM standards and conformed to all necessary standard requirements. Table 1 indicates physical properties gained as a result of coarse aggregate. The maximum size of the aggregate was 12.5 mm.

Table 1; Physical properties of aggregates

Aggregates	Unit weight (Kg/m ³)	Sieve analysis (FM)	Moisture content (%)	Specific Gravity	Absorption Capacity %
Sand	1,565	2.91	2	2.5	1.53
Gravel	1,726	5.54	0.76	2.69	1.26
Scoria	844	5.31	6.4	1.78	18.3

2.2. Mix proportion for making IHCB (Interlocking Hollow Concrete Block)

So, the actual mix ratio of ingredients that researcher used for this research is cement to sand to gravel to scoria coarser aggregate was 1:5:1:1 that imply 1 part of cement with 5 parts of sand, 1 part of gravel, and 1 part of scoria. And water to cement ratio was 0.64 considering the absorption and moisture contents of the aggregates.

2.3. Research design

In order to attain the relative output, qualitative approach of the research strategy through preparing questionnaires and interviews for local construction firms around Hossana town was required to assess the existing construction practice of masonry works. And, the quantitative approaches of the study was conducted in terms of determining the variation of cost and time when compared to the masonry works from stone, brick, and HCB units.

2.4. Study population

Among the public buildings and real states houses in Hossana town, twelve (12) construction site; and contractor, consultant, and workers on site focused for this study. Researcher selected a sample of questionnaires and open interview from Hosanna town construction project environment contractors, managers, engineers, supervisors, and other labors who worked on site to assess how handle concrete construction material on site. The estimated total population size of this study was 1,480 workers those involved on various activities of construction works in the town.

2.5. Sampling technique and sample size

The collection of samples was through a stratified sampling. A stratified sampling is a technique which consist of dividing population under study into mini groups namely strata. Before sampling, the study population was divided into features of significance for the study. In our case, given the stratum was based on various positions of works such as consultant, contractor, Daily labors.

The sample size for the study was arrived at using statistical calculation [13]

$SS = N / ((1 + Ne^2))$, if the total population is >30Equation [1]

Where: N = population, e = error, SS = sample size

Now, N is the population = 1486 + 9 + 0 within Hosanna town let e = 10%.

So, $SS = 1480 / ((1 + 1480 \cdot [0.1]^2)) = 94$

The sampling technique regarding to experimental work of the product for this research was a non-probability sampling technique which is the purposive method. For material laboratory test, the samples was depending on the types of test requirement and standards. And, size of sample of all aggregates in this study determined by using chute-type mechanical sample splitter method which is dividing of sample as described and beneath the blanket in even amount.

Based on types and size of mix materials that to be used for two model interlocking hollow concrete block and test categories, twenty seven (27) samples in three different specimens were casted for each 7th, 14th, 21st, and 28th day test (Table 2).

Table 2: Total sample size used

SAMPLE CODE	Samples Code				Total
	Number of cube samples For 7 th day	For 14 th day	For 21 th day	For 28 th day	
M01HCBc	03	03	03	03	12
M01HCBu	03	03	03	03	12
M01HCBw				03	03
Total	06	06	06	09	27

Where; M01HCBc stands for Model 01 Interlocking Hollow Concrete Block sample that used for Compressive strength tests, M01HCBu is for Model 01 Interlocking Hollow Concrete Block sample that used for Unit weight determination, and M01HCBw is for Model 01 interlocking hollow concrete block sample that used for water absorption tests.

2.6. Test on hardened concrete

The tests on hardened concreted were taken as per the standards of ASTM as mentioned in the Table 3 below.

Table 3. Standard Test Method used to conduct the laboratory experimental works.

1	Unit weight	ASTM C 138M-17
2	Compressive strength	ASTM C 469/ ASTM C109M-16
3	Water absorption	ASTM C 140-03

3. Results and Discussions

3.1. The current practice of masonry work of building construction in Hossana Town

A multiple set of questionnaires survey were distributed for both public and private building construction projects in order to review the existing different materials that used as masonry units. According to the respondents' rate (Table 4), HCB was ranked as the mostly used product for a masonry works of building construction in a Hossana town with a Percentage = 100. As shown in the figure, a dressed stone and timber has been used as masonry units with highest percentage with value of 47.67% and 18.60% respectively. But unfortunately, there was current experience of using interlocking concrete block for a masonry works of building construction in a referred town with a value of 2.31%. In addition, the stabilized interlocking soil block yielded a minimum rank to be used as masonry units with a 9.30% in a building construction practice of Hossana town.

Table 4: Masonry units of building construction used in Hossana Town

No.	Types of Material	Number of Respondent	% of Usage
1	Hollow concrete blocks	8	100.00
2	Mixed	86	44.19
3	Dressed stone	26	30.23
4	Timber	7	11.63
5	Brick	5	9.30
6	Agro - stone	10	8.14
7	Soil stabilized interlocking blocks	2	5.81
8	Interlocking Concrete blocks	38	2.31

3.2. The factor affects the current practice of using mortar - less (Interlocking) blocks in Hossana Town

This part of the study was performed by considering the rate given by the respondents for the five (05) Likert scales on factors affecting on the current use of interlocking block for a mortar-less masonry works as alternative building construction, and RII (Relative Importance index) was calculated. Based on the response of the participants as shown in Table 5 below, absence of a product supply in a local market like other brick, HCB, Stone, etc. was a factor ranked as the most critical factor affected the use of IHCB with RII= 0.97. Lack of knowledge in using such a product due to more people follows a traditional masonry works for building construction, and the sustainability and applicability for load bearing masonry is not determined are the following factors of affecting the use of IHCB with RII = 0.95 and RII = 0.79 respectively. Based on the respondent rate, perception on quality of a product will be poor to use as masonry units considered as a factor for not experiencing of use of such a product with a least RII = 0.58.

Table 5: Factor affects the current Practice of using Interlocking hollow concrete blocks in Hossana Town

No.	Factors affected the use of Interlocking blocks as masonry units	RII
1	Lack of knowledge in using such a product due to more people follows a traditional masonry works for building construction	0.95
2	Absence of a product supply in a local market like other brick, HCB, Stone, etc.	0.97
3	Difficulties to get skilled person to work the masonry by using interlocking concrete blocks	0.77
4	Perception on quality of a product will be poor to use as masonry units	0.58
5	Due to its high price when compared to other local masonry units like burnt bricks, HCB, Stone, etc.	0.63
6	The sustainability and applicability for load bearing masonry is not determined	0.79

3.3. Model of the Mortar-less masonry Units (Interlocking Hollow concrete Blocks (IHCB))

AutoCAD 2012 was used to develop a model of interlocking blocks that can be produced from concrete in order to enable mortar - less masonry works as better alternatives of building construction method. According to the output of modeling, there are two basic models developed as described below.

a) Model - 01

A hollow along the horizontal axis with the size of 200 x 200 x 400 mm, and 100 x 200x 400 mm was mould was used to establish this model. Figure 1 and Figure 2 shows that the top view from outer part of the product it acts as a key and the bottom as a lock.

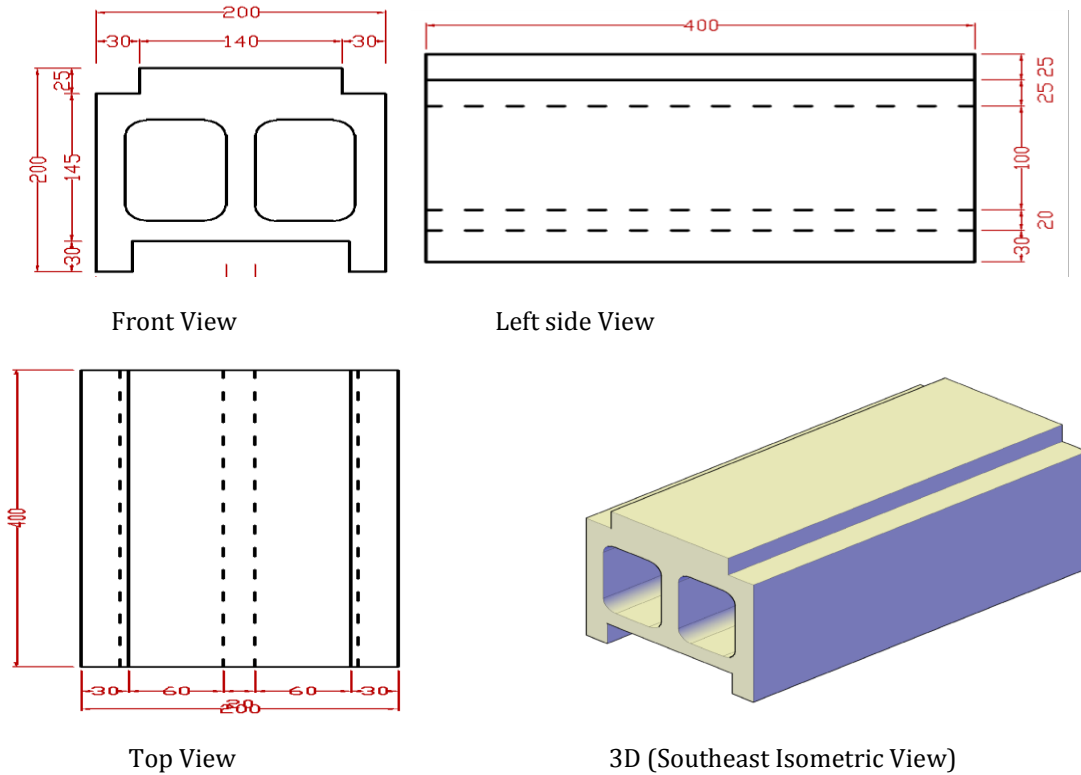
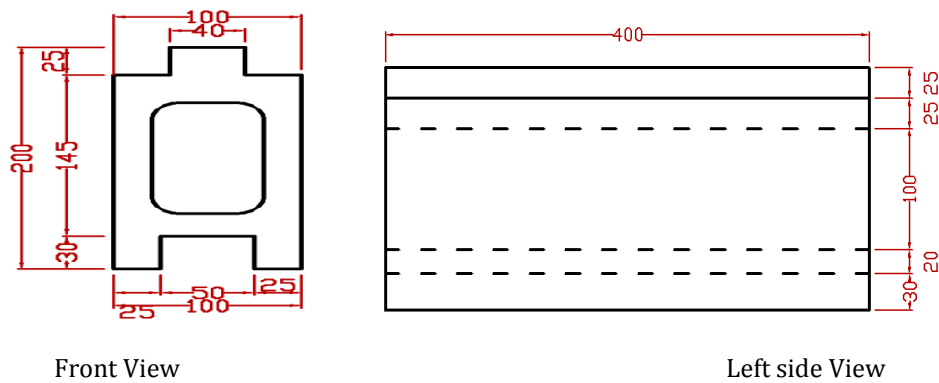

Figure 1: Model 01 (200*200*400 mm) of interlocking hollow concrete block



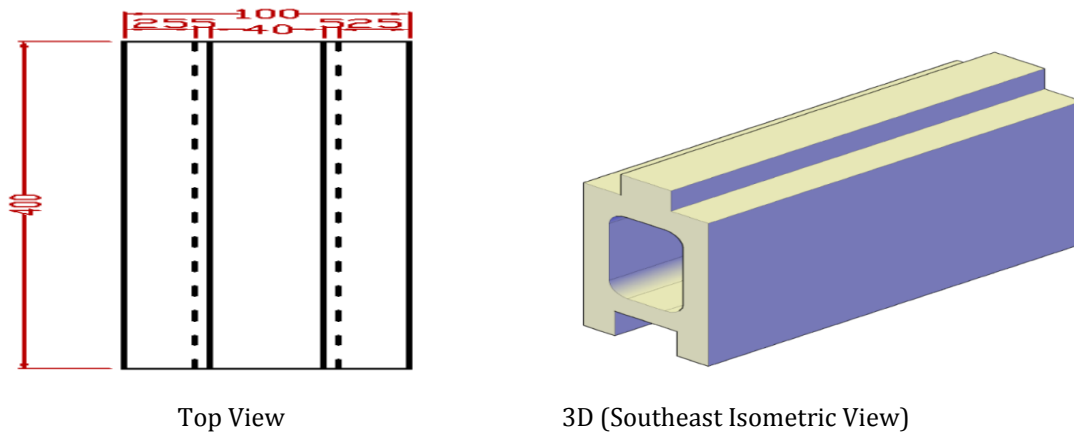
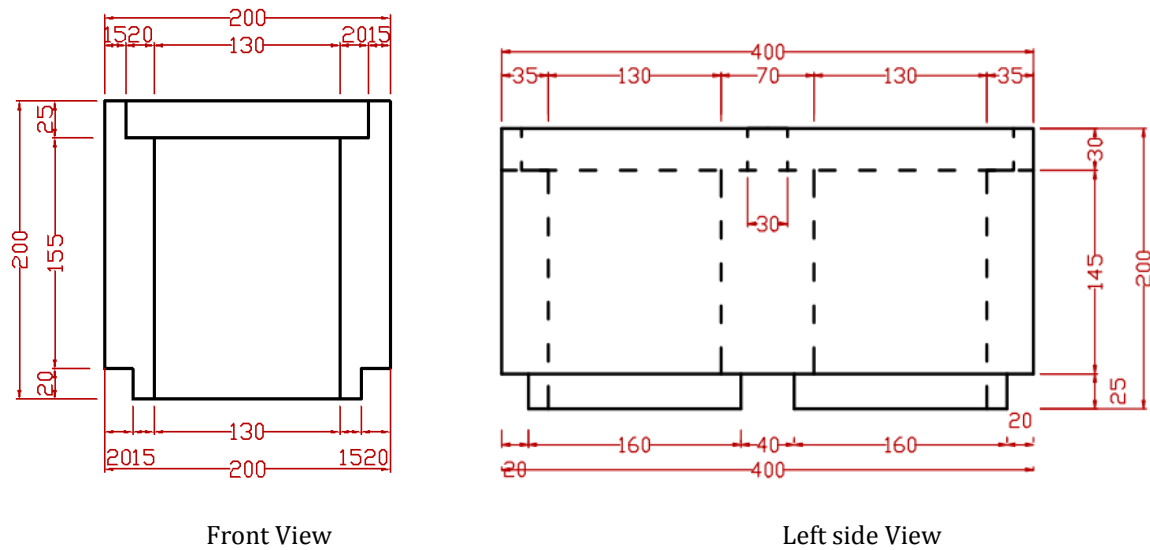
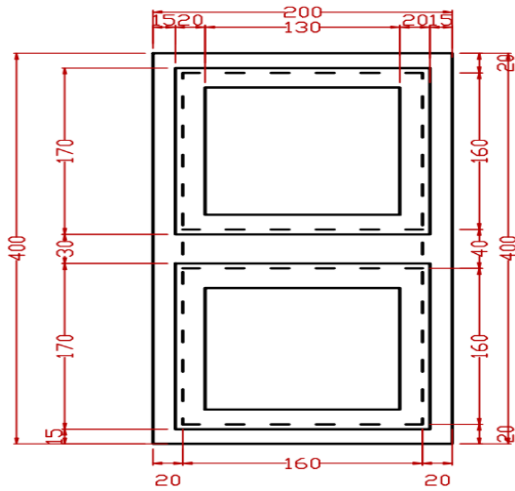

Figure 2: Model 01 (100*200*400 mm) of interlocking hollow concrete block

b) Model - 02

According to this model, a hollow is along the vertical axis with the size of 200 x 200 x 400 mm. As shown in the top view from outer part of the product it acts as a lock and the bottom as a key to make it interlock-able to use as masonry units that can be coursed without mortar (Figure 3).





Top View

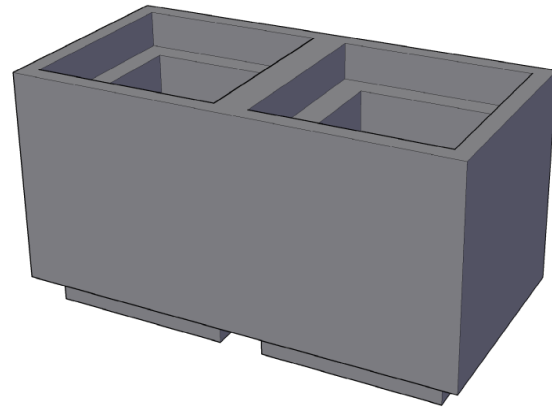

3D (Southeast Isometric View)

Figure 3: Model 02 (200*200*400 mm) of interlocking Hollow concrete block

3.4. Workability test on fresh concrete mix

As the result from laboratory, the slump of mix of Interlocking Hollow Concrete Block was very dry mix. Based on the Laboratory record, the slump of fresh mix of IHCB yielded to 8 mm.

3.5. Properties of hardened interlocking hollow concrete block

a) Unit weight of IHCB

To analyze the dry density of each specimen of concrete (IHCB) samples were prepared with size of 100 x 200 x 400 mm and cured for 7, 14, 21 and 28th days. According to previous literature, the density of hollow concrete block should not be less than 1200 Kg/m³. The dry unit weight measured result indicates that average weight that recoded within each curing age met the requirement (Figure 4). The maximum density achieved was 1222.73 Kg/m³ for an interlocking hollow concrete block after 28th day curing period. While, the minimum density been 1211.11 Kg/m³ for a sample at 7th day. As the result indicates when the curing age of the sample increases the density of IHCB also increases slightly. Generally, the unit weight of solid concrete block meets the requirement of ASTM standards practically.

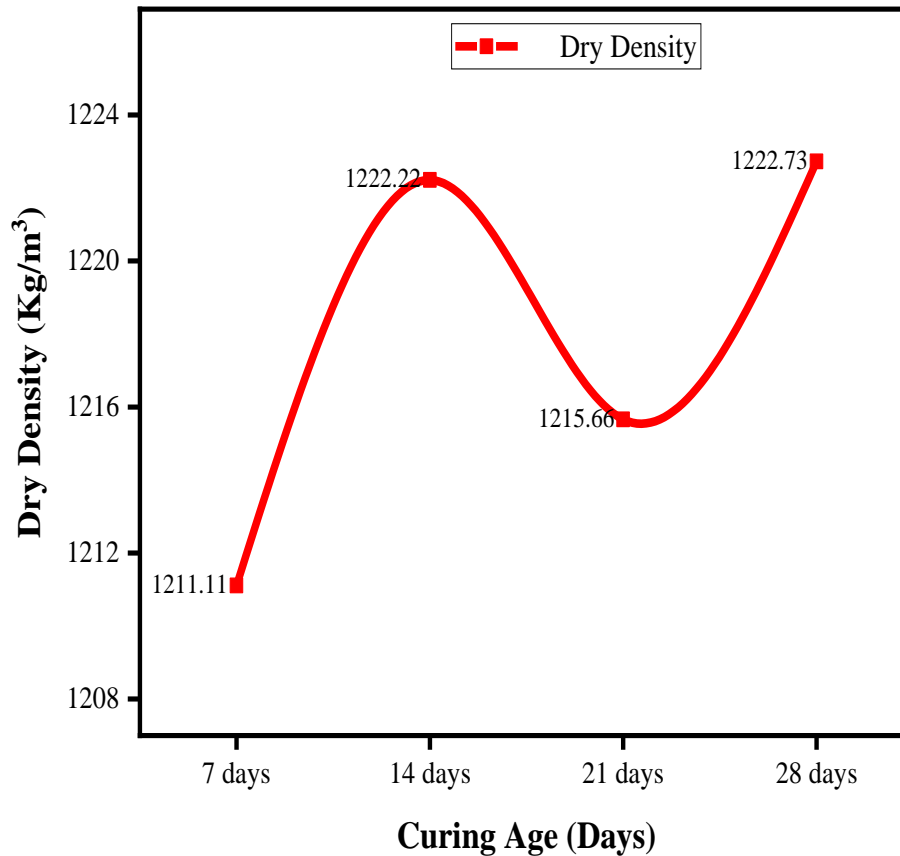

Figure 4: Unit weight of interlocking hollow concrete block

b) Compressive strength of concrete

The test was focused to check the compression resistance of a product before recommending it for application of masonry works. The result was analyzed in terms of specimens with a size of 100 x 200 x 400 mm for each curing period of interlocking hollow concrete block as shown in Figure 5 below. The 7th day age of cured result of interlocking hollow concrete block was potentially less to resist the compression stress and it is about 0.45 MPa which is 18.92% when compared to that of the same product at 28th day curing age. Furthermore, curing period increases the compressive strength increases in the same manner. Sample at 14th day was 1.84 MPa. Meanwhile, compressive strength of IHCB for curing period of 21 days after the cube was 2.01 MPa which achieved about 84.26% in terms of 28th day aged. As the result shows most of the time in our local construction industry basically for masonry work the contractors use the either of hollow or solid concrete block products with in this curing period even if it not achieves its relevant required strength. Additionally, the maximum compressive strength achieved for this sample of interlocking hollow concrete block product was 2.39 MPa (N/mm²). Based on the experimental results of this investigation recorded at 28th day curing period, these products can be categorized in the Class C according to ESC D3.301 that will be used for non-load bearing walls.

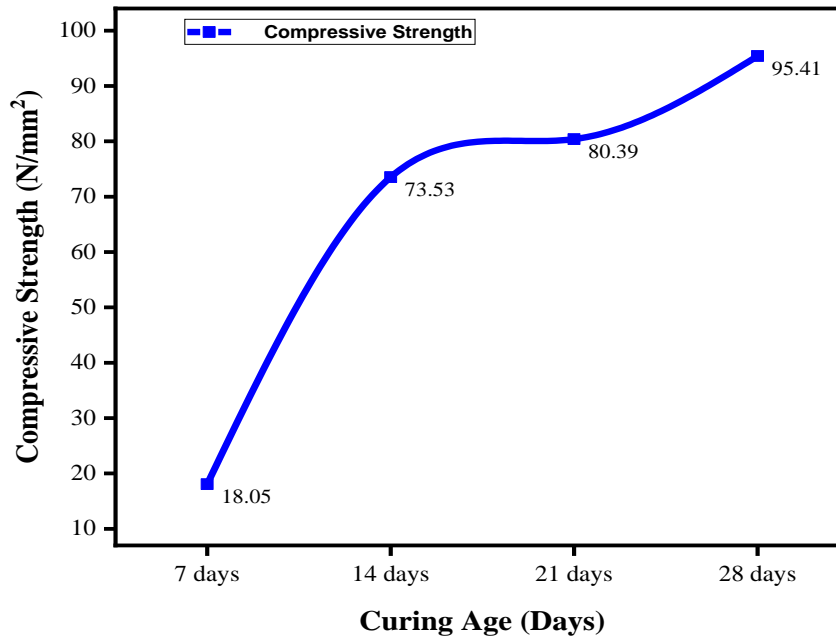

Figure 5: Compressive Strength of IHCB

c) Water Absorption

Three full sizes of IHCB products were completely immersed in clean water that prepared on curing tank at a room temperature for 24 hours. From the examined test results, the prepared sample yielded 8.07 kg after immersed in water for 24 hours, and been measured about 6.93 Kg when dried in oven with the same time extents.

Absorption, percent = $(8.07 - 6.93)/6.93 * 100 = 16.45\%$
 Where, A = wet mass = 8.07 kg.
 B = dry mass of unit = 6.93kg.

As displays in the figure, the water absorption capacity of the product was 16.45% which is greater than the standard requirements for concrete masonry units that have to be less than 10%. This result show that product is sensitive for absorption of water due to either using of scoria as one of mix material and/or porous in the hardened product resulted by less compaction. So, it is the researcher’s recommendation to use such a product in internal walls of building construction, and to use a proper plastering to prevent the penetration of rain water if the product used for external masonry works.

3.6. Cost and time comparison of masonry works from IHCB with other commonly used materials

a) Cost comparison

in this part, the cost of masonry works that will be made from Interlocking Hollow Concrete Blocks were evaluated comparatively with the other materials basically, nominal HCB, stone, and brick works. Considering the mix ratio, dry shrinkage and wastage during the actual work, the quantity of each material per units determined. Then, the purchase price of material based on the current local market surveyed and converted to unit price. Based on current material price of some of materials to be used for this study listed below under Table 6.

Table 6: Unit cost of ingredients and materials

S.No.	Material Type	Unit	Unit Rate (ETB)
1	Cement (Dangote)	Qtl	650
2	Sand	m ³	960
3	Coarse aggregate	m ³	950
4	Scoria	m ³	275
5	Stone (Ambo)	m ³	400
6	HCB(100x200x400 mm size)	Pcs	15.50
7	Brick	Pcs	12

Table shows the detailed unit cost comparisons to produce 1 m² wall having 20 cm thick which made from HCB, IHCB, stone, and bricks, and the percentage difference in cost with respect to the IHCB. As seen from the table, there was almost similar costs for both labor and equipment for either product of IHCB and HCB, only the shape of the products and their number that would be required for a 1m² varies. So, due to similarity in the production method, type and amount material used, it was considered the equivalent the cost of IHCB to that of nominal HCB with the same size. It was focused to compare the unit cost of a 20 cm thick masonry wall in 1 m² due to use of IHCB with other masonry units (HCB, Bricks, and Stone) that practiced by high rates in Hossana town. Considering the current market price of the products and materials to be used for a 20 cm thick wall including 15% of overhead cost and 10% profit by neglecting the cost of equipments/tools, the total unit cost of 1 m² building masonry wall computed and explained in terms of HCB, IHCB, stone, and brick units. The table shows the unit cost of a 1 m² 20cm thick works from IHCB ranked the least cost which is equals to 386.89 ETB/m² that saves a 30.69 % when compared to that of conventional Hollow Concrete Blocks,130.36% than stone masonry, 319.9% than brick. Due to the cost of material required per a square meter, and the minimum labor hourly output, brick wall ranked a highest unit cost when compared to another material based wall which is equals to 1624.57 Birr/m².

Table 7: Unit cost of 1 m² 20 cm thick wall from HCB, IHCB, stone, and bricks

Materials used for Masonry	Unit Cost	Manpower Unit Cost	Overhead Cost	Profit Cost	Total Unit Cost	% of differences in cost with respect to IHCB
class C, HCB	305.69	98.82	60.68	40.45	505.63	30.69
class C, IHCB	295.98	13.53	46.43	30.95	386.89	0.00
Stone	282.35	430.65	106.95	71.30	891.26	130.36
Full size brick wall	1311.88	138.63	101.54	72.53	1624.57	319.90

b) Time comparison

In order to compare the construction time taken between the IHCB and the other masonry units, the actual time required to build a 1 m² of bolck works from IHCB were recorded after preapring the sample products and compared to the time required fro the same area of block works. For the rest of the masonry units, the datas' were taken by interbiewing masons' from construction sites, and the comparison of the result is shown in Table . According to the observation results of time recoded, it required an average of 7.5 min per 1 m² of block. According to the collected dat's, brick and dressed stone was the highest bolck works that required more times compared to the others with 75.00 and 72.69 minutes, respectively; while to build 1 m² agro stone masonry works were the second least working time next to IHCB which was equals to 15 min even if it is not

commonly used around the Hossana town. The table indicates that the time required to accomplish a square meter block works from bricks was 75 min, HCB taken 45.74 min, and a dressed stone wall takes 72.69 minutes. Using of IHCB for a masonry work fasters five times than the wall construction from nominal HCB, nine times faster when compared with a building wall construction from brick and stone construction. This enhances fast construction of masonry works that will be resulted due to deducting the need of the mortar, and the setting out to adjust the horizontal and vertical alignment of a specific wall. Figure demonstrates the the connection of interlocking mortar – less masonry units with IHCB.



Figure 6: Coursing a masonry using IHCB (Mortar - less) units

Table 6: A time limits to build a wall from HCB, IHCB, stone, and other materials

Materials	Indexed Time that will be required (min)	Percentage of the differences in a time
Brick	75.00	900.00
HCB	45.74	509.88
Dressed Stone	72.69	869.23
Agro-Stone	15.00	100.00
Soil stabilized interlocking blocks	23.00	206.67
Timber	56.00	646.67
IHCB	7.50	0.00

4. CONCLUSION

The main aims of this study were to identify the current masonry units that used in Hossana town, develop interlocking mortar-less concrete blocks for masonry works, assess their physical properties, to compare the cost and time required to build masonry units. According to investigated analysis, the following listed conclusions are made;

- ✚ HCB was the widely used product for a masonry works of building construction in a Hossana town when compared to bricks, a dressed stone, stabilized interlocking soil block and timber.
- ✚ There has been no experience of using interlocking concrete block for a masonry works of building construction in a town.

- ✦ The absence of a product supply in a local market like other brick, HCB, Stone, etc. was a factor ranked as the most critical factor resulted on the negligence on the use of IHCB. However, lack of knowledge in using such a product due to more people follows a traditional masonry works for building construction, and the sustainability and applicability for load bearing masonry were not determined the factors of affecting the use of IHCB.
- ✦ There could be two basic models developed by setting a hollow along the horizontal axis with the size of 200 x 200 x 400 mm, and 100 x 200x 400 mm
- ✦ The maximum density achieved was 1222.73 Kg/m³ for an interlocking hollow concrete block after 28th day curing period that meets the requirement of ASTM standards, and the maximum compressive strength achieved for the interlocking hollow concrete block product was 2.39 MPa (N/mm²).
- ✦ The water absorption capacity of the product was 16.45% which greater than the standard requirements for concrete masonry units that have to be less than 10%, which requires using a proper plastering to prevent the penetration of rain water if the product used for external masonry works.
- ✦ compared to other masonry units, the unit cost and the required time to build a masonry block works from IHCB was lower and saves about a 30.69% to 319.9% cost of the others.

Conflict of Interest

- ❖ **No conflict of interest among the Authors.**

REFERENCES

1. Roser M. Future Population Growth. Our World in Data. 2013.
2. Aigbavboa C, Thwala, W. Prediction of Residential Satisfaction in South African Low-Income Housing: Role of Beneficiaries. Journal of Architectural Engineering. 2018; 24(01).
3. A Holistic Approach to Affordable Housing [Internet]. 2019. Available from: <https://digitalcommons.wpi.edu/cgi/viewcontent.cgi?article=7861&context=mqp-all>
4. Krishnaiah S RPS. Effects of Clay on Soil Cement Block. The 12th International Conference of International Association for Computer Methods and Advances in Geomechanics (IACMAG); Goa, India. 2008.
5. Alzahrani J, Emsley M. The impact of contractors' attributes on construction project success: A post construction evaluation. International Journal of Project Management. 2013; 31:313-322.
6. Barnes R. Boosting affordable housing in African using ABTs. Construction 2015 September 18.
7. Rodrigues H, Šipoš TK. Masonry Buildings: Research and Practice. Buildings. 2019.
8. Etherington AB. Interlocking Soil-Cement Bricks- A Modified Cinva Ram Brick Making Machine. Asian Institute of Technology-Human Settlement Development Division (AIT-HSD); Bangkok1983.
9. Eires R, Sturm T, Camões A, Ramos LF. STUDY OF A NEW INTERLOCKING STABILISED COMPRESSED EARTH MASONRY BLOCK. 2012.
10. Davis L, Maïni S, Royo Olid J. Feasibility report for compressed stabilised earth block (CSEB) production and use in the north and east of Sri Lanka Publications Office of the European Union; 2018.

11. Ahmad S, Sadam, Hussain., Awais, M., Asif, Mohd., Muzamil, H., Ahmad, Rafiq., Ahmad, S. . The Behavior of Interlocking Of Masonry Units/Blocks. Journal of Engineering. 2014;04(03):39-47.
12. Sayanthan R, Ilamaran, S., Rifdy, M., Nanayakkara, S.M.A. DEVELOPMENT OF INTERLOCKING LIGHTWEIGHT CEMENT BLOCKS. International Conference on Kandy; Sri Lanka: Structural Engineering and Construction Management; 2013.
13. Yamane, T. Statistics, an Introductory Analysis, 2nd Ed., New York: Harper and Row. 1967.
14. Jablonski N. Mix designs for concrete block by Proportioning using the fineness modulus method. Milwaukee: J960363; 1996.